

© 2014 Mazda Motor of America, Inc.

Subject: WIND NOISE FROM DOOR WINDOW EDGE(S) AT 37 MPH OR HIGHER	Bulletin No: 09-036/14
	Last Issued: 08/29/2014

APPLICABLE MODEL(S)/VINS

2014-2015 Mazda6 vehicles with VINs lower than JM1 GJ ***** 167429 (produced before January 07, 2014)

DESCRIPTION

Some vehicles may exhibit a wind noise from the door window edge(s), while driving. The wind noise is most pronounced at approximately 50 mph (81 km/h) on a smooth road. The wind noise may be caused by air passing through gaps between the door edge and the corresponding body panel.

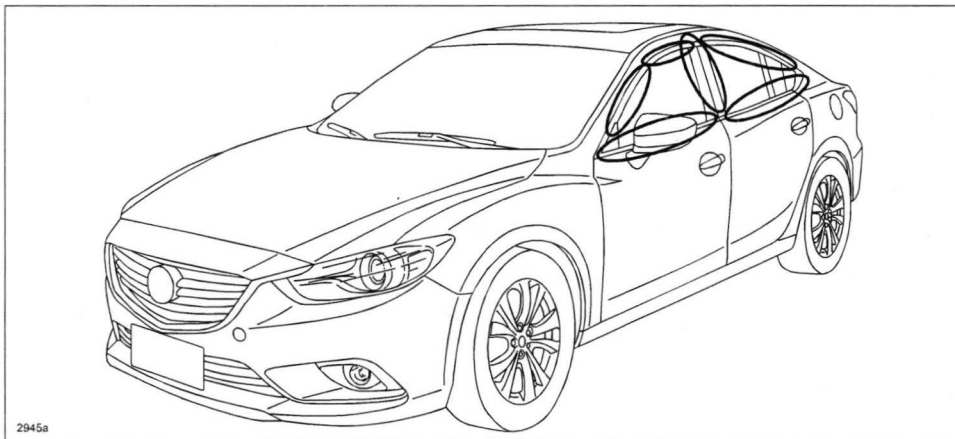

Customers having this concern should have their vehicle repaired using the following repair procedure.

REPAIR OUTLINE

Step			
1.	Has the customer wind noise complaint been verified?	Yes	Proceed to Step 2.
		No	This bulletin does not apply.
2.	Perform VERIFICATION PROCEDURE. Did the wind noise decrease with the masking tape installed to the upper part of the front belt line molding?	Yes	Perform REPAIR PROCEDURE A
		No	Perform REPAIR PROCEDURE A and B

CONSUMER NOTICE: The information and instructions in this bulletin are intended for use by skilled technicians. Mazda technicians utilize the proper tools/equipment and take training to correctly and safely maintain Mazda vehicles. These instructions should not be performed by "do-it-yourselfers." Customers should not assume this bulletin applies to their vehicle or that their vehicle will develop the described concern. To determine if the information applies, customers should contact their nearest authorized Mazda dealership. Mazda North American Operations reserves the right to alter the specifications and contents of this bulletin without obligation or advance notice. All rights reserved. No part of this bulletin may be reproduced in any form or by any means, electronic or mechanical---including photocopying and recording and the use of any kind of information storage and retrieval system ---without permission in writing.

VERIFICATION PROCEDURE

1. Apply masking tape (A) to the upper part of the front belt line molding of the front door with the noise. [Apply masking tape to properly cover the position shown in the red circle.(B)]
2. Test drive the vehicle at approximately 50 mph (81 km/h) on a smooth road. Did the wind noise decrease?
 - a. Yes - Perform REPAIR PROCEDURE A.
 - b. No - Perform REPAIR PROCEDURE A and B on any door with the noise.

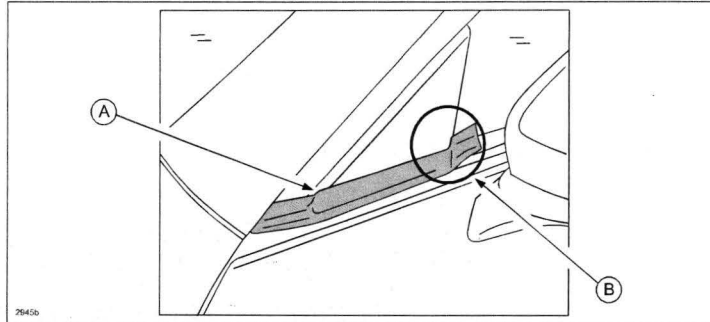

NOTE: Condition may be difficult to duplicate under the following conditions:

- above 50 mph (81 km/h)
- rough roads
- heavy traffic
- windy conditions

REPAIR PROCEDURE A

Replace the inner weather strip and the front beltline molding.

1. Fully open the front door glass.
2. Remove the front door trim. Refer to MS3 online or Workshop Manual (section 09-17 FRONT DOOR TRIM REMOVAL/INSTALLATION).
3. Remove the inner weather strip (A).

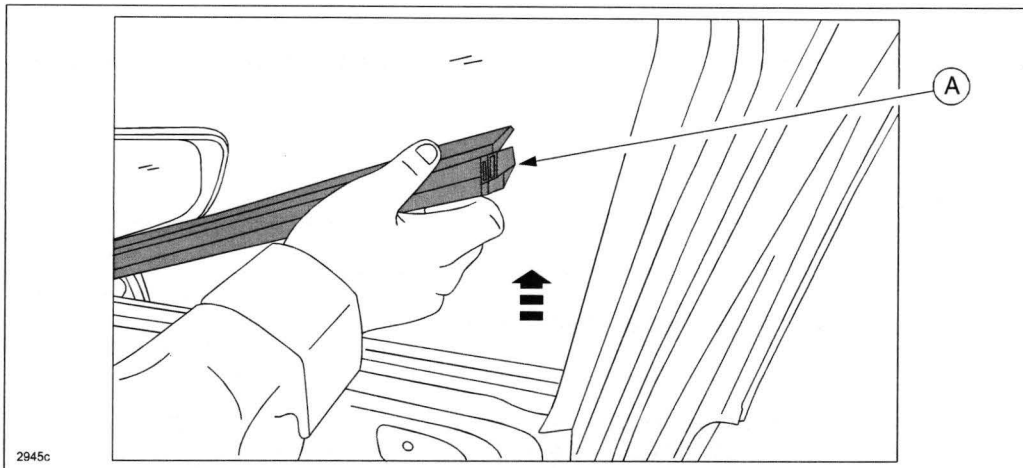

4. Install a new inner weather strip, and then slide it until it contacts the rear glass run channel.

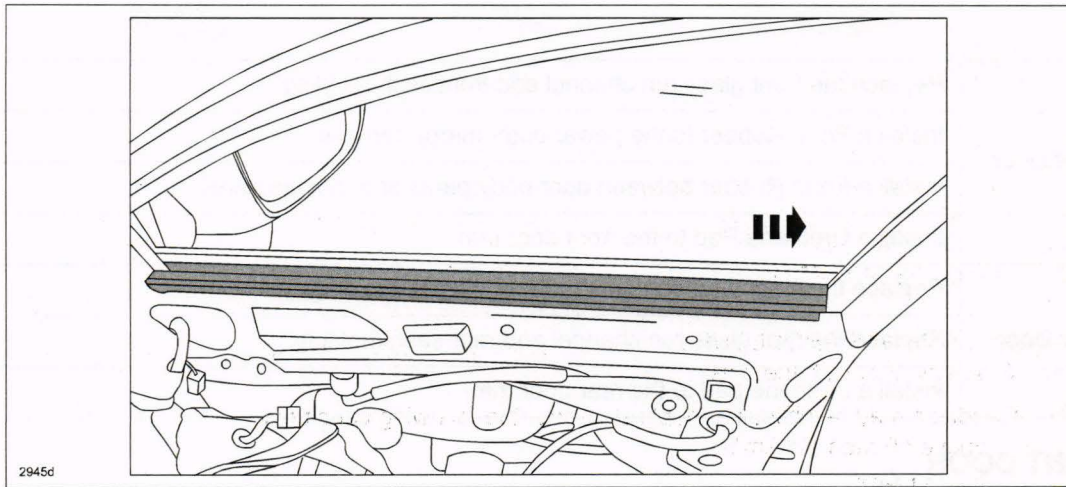

5. Install a new front beltline molding. Refer to MS3 online or Workshop Manual (section 09-16 FRONT BELT-LINE MOLDING REMOVAL/INSTALLATION).
6. Install a new front door trim. Refer to MS3 online or Workshop Manual (section 09-17 FRONT DOOR TRIM REMOVAL/INSTALLATION).
7. Verify repair.

REPAIR PROCEDURE B

Front Door	Replace the front glass run channel and front sash molding.
	Install a Form Rubber to the power outer mirror harness.
	Install a Form Rubber between door body panel and module panel.
	Install a Urethane Pad to the front door trim.
Rear Door	Replace the inner weather strip and rear beltline molding.
	Replace the rear glass run channel and rear sash molding.
	Install a urethane pad to the rear door trim.

FRONT DOOR

1. Pull both edges of the front glass run channel and remove it from the front door.

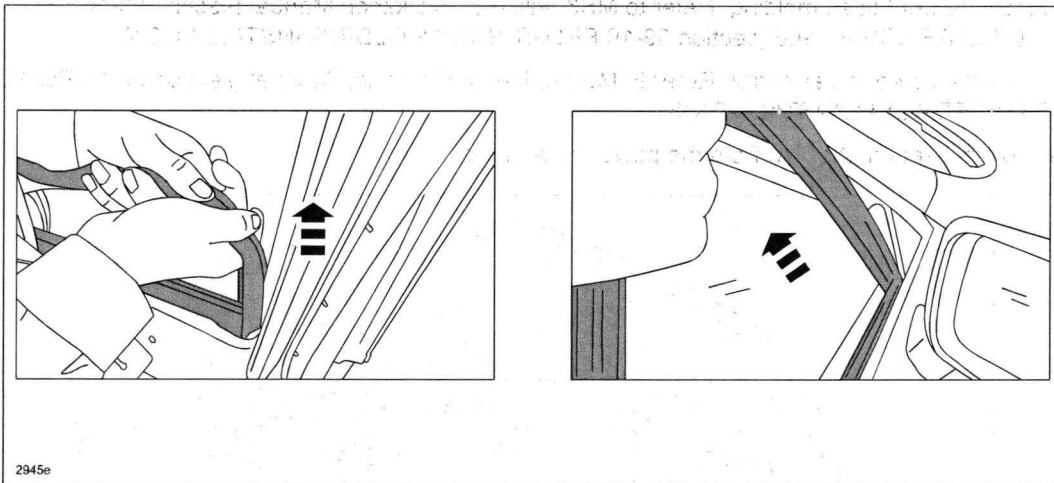

2. Apply soap sud to the contacting surface of the new front glass run channel to the front door glass and door panel

3. Insert both ends of the front door glass run channel between the front door glass and door panel, then install the whole front door glass run channel.

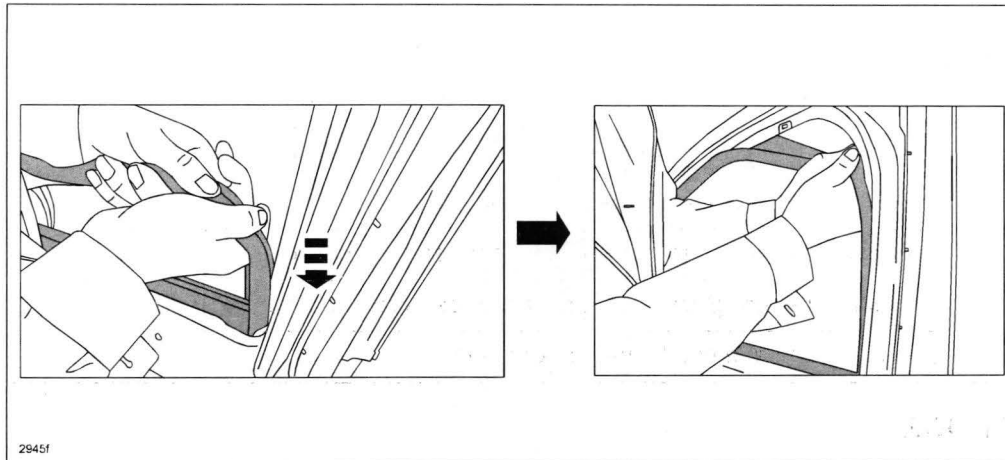

4. Replace the front sash molding. Refer to MS3 online or Workshop Manual (section 09-16 FRONT SASH MOLDING REMOVAL) and (section 09-16 FRONT SASH MOLDING INSTALLATION).
5. Remove the power outer mirror. Refer to MS3 online or Workshop Manual (section 09-16 POWER OUTER MIRROR REMOVAL/INSTALLATION).
6. Remove the seal rubber (A) from the power outer mirror.

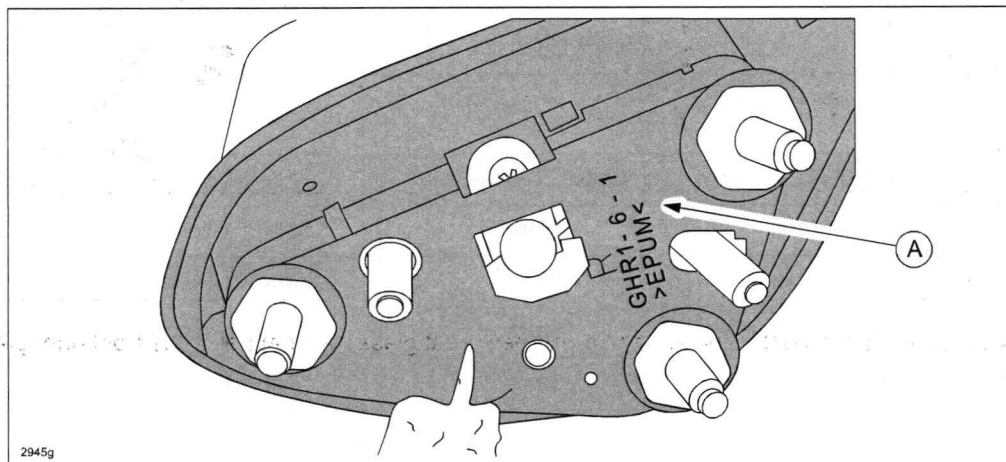

7. The image and table below show the pieces needed to perform door repairs. Select a 5 mm thick sheet of Form Rubber from the "Noise Repair Kit K001 W0 225". Cut eight pieces as shown below.

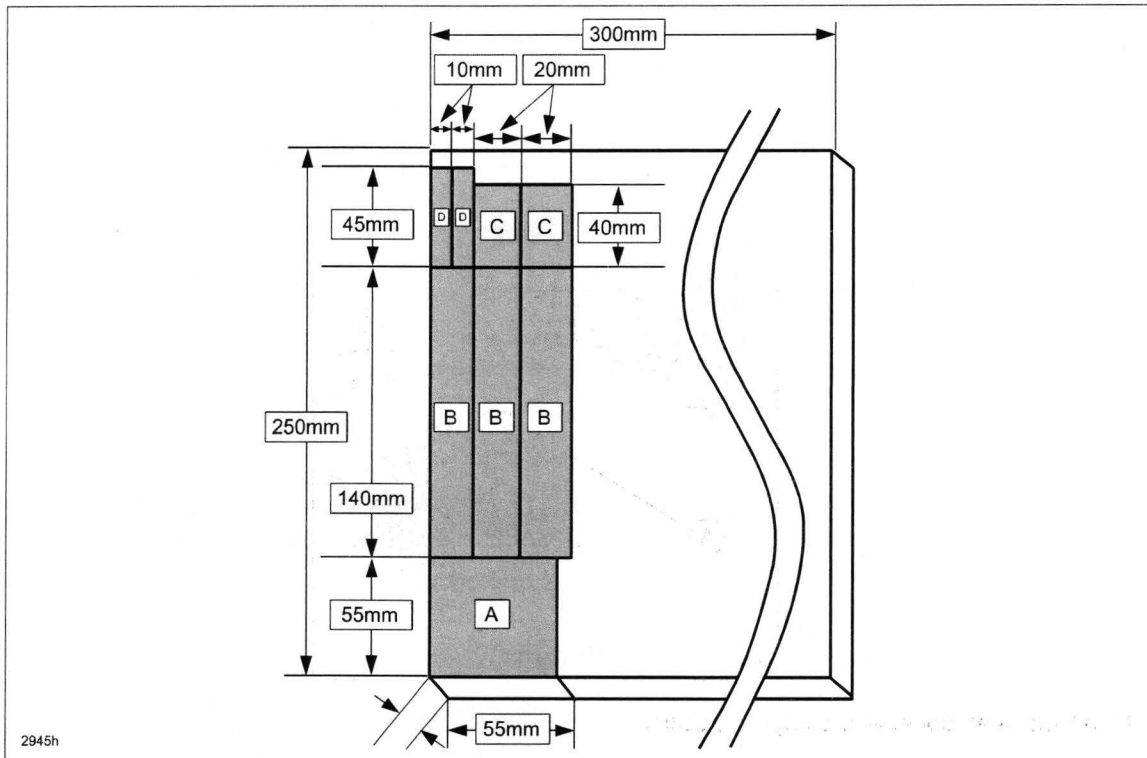

Piece	Sheet Type	Sheet Thickness	Size	Quantity
A	Form Rubber	5mm	55mm X 55mm	1
B	Form Rubber	5mm	20mm X 140mm	3
C	Form Rubber	5mm	20mm X 40mm	2
D	Form Rubber	5mm	10mm X 45mm	2

8. Attach the cut Form Rubber (A) (55mm X 55mm size) all around the harness, positioning one end at the mirror side end of harness (B).

NOTE: Do not overlap the pad on the harness.

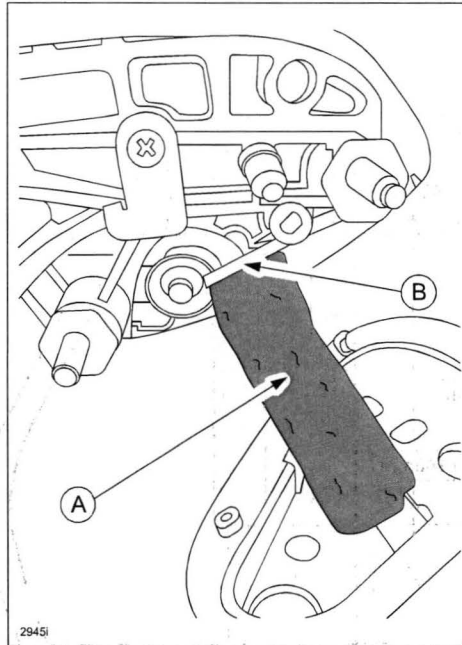

9. Install the seal rubber at the original position.

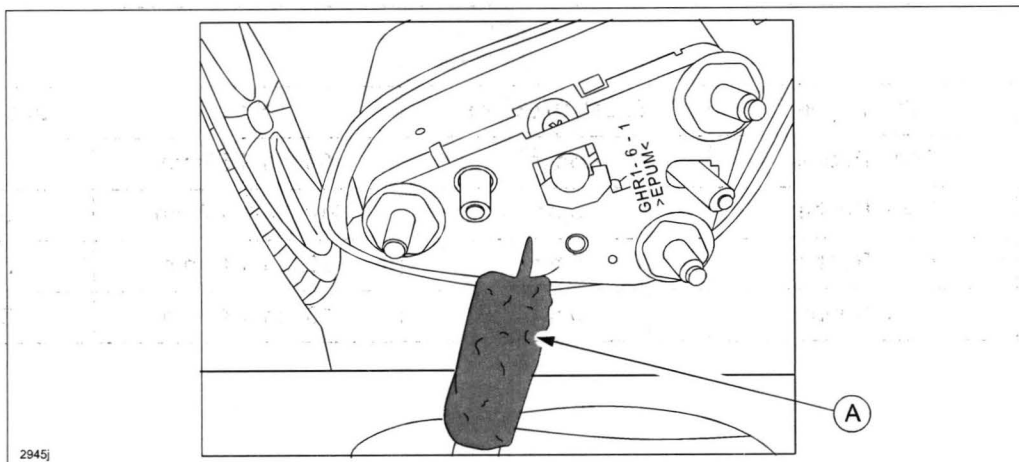

NOTE: After installing the seal rubber, confirm if the pad is installed to the harness correctly (A).

10. Install the power outer mirror. Refer to MS3 online or Workshop Manual (section 09-16 POWER OUTER MIRROR REMOVAL/INSTALLATION).

11. Remove the fixing bolts and fasteners of front door module panel marked in the below figure.

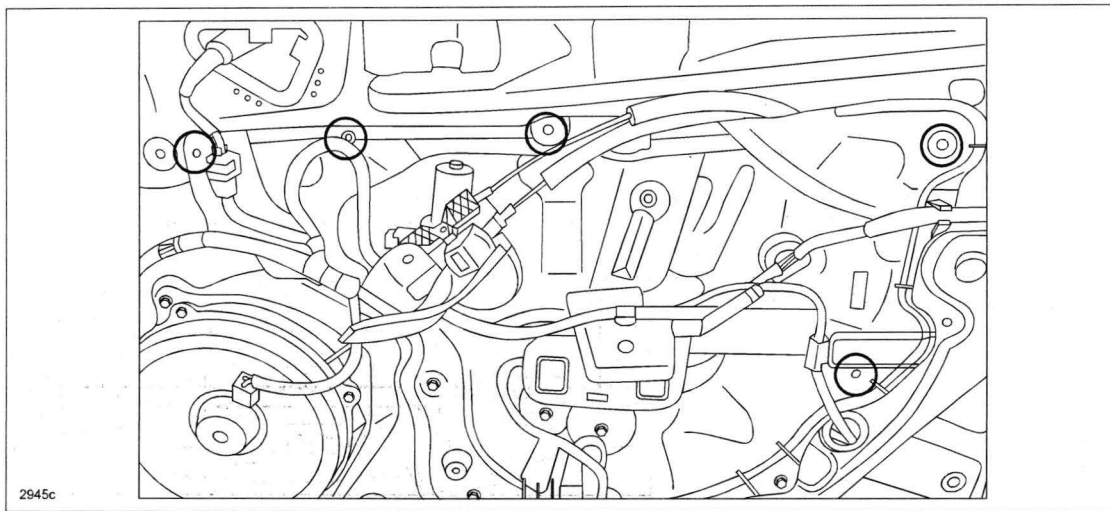

12. Prepare 1 set of 3 pieces of cut Form Rubber (B) 20mm X 140mm size in layer.

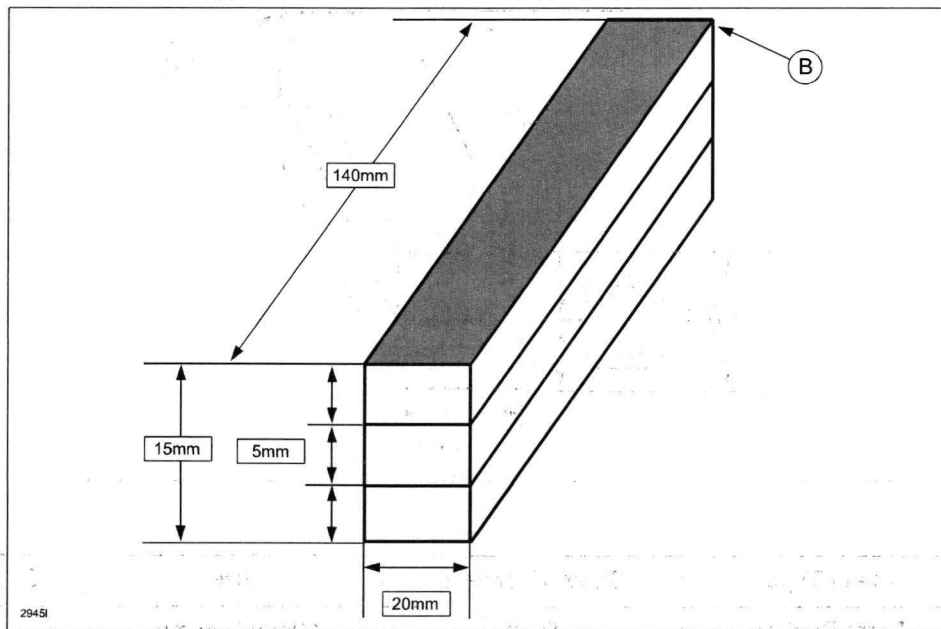

Piece	Sheet Type	Sheet Thickness	Size	Quantity
B	Form Rubber	5mm	20mm X 140mm	3

13. Attach the layered Form Rubber (B) to the back side of front door module panel, positioning one end at the break point of butyl tape (A) and along the upper edge of the front door module panel.

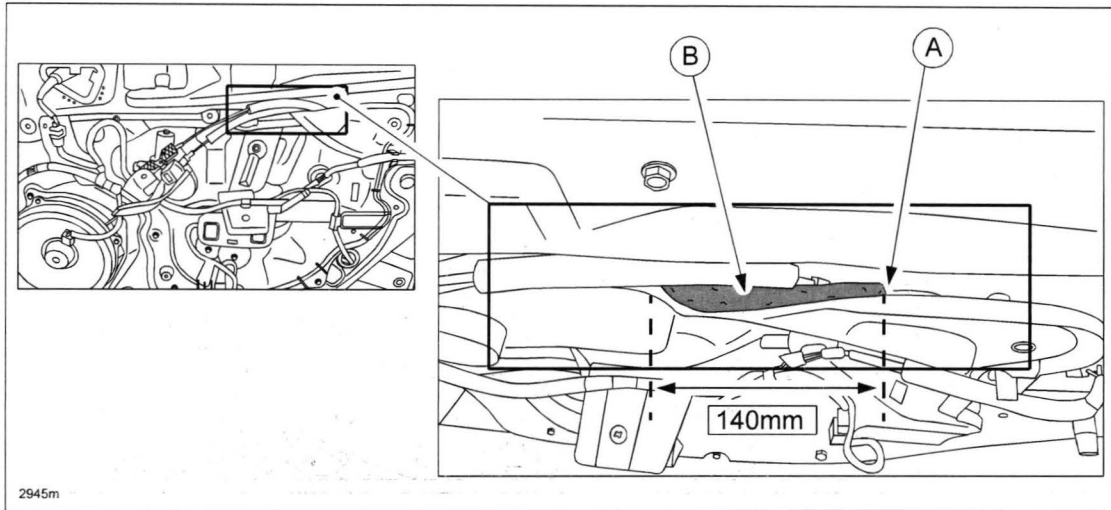

14. Prepare 1 set of 2 pieces of cut Form Rubber (D) 10mm X 45mm size.

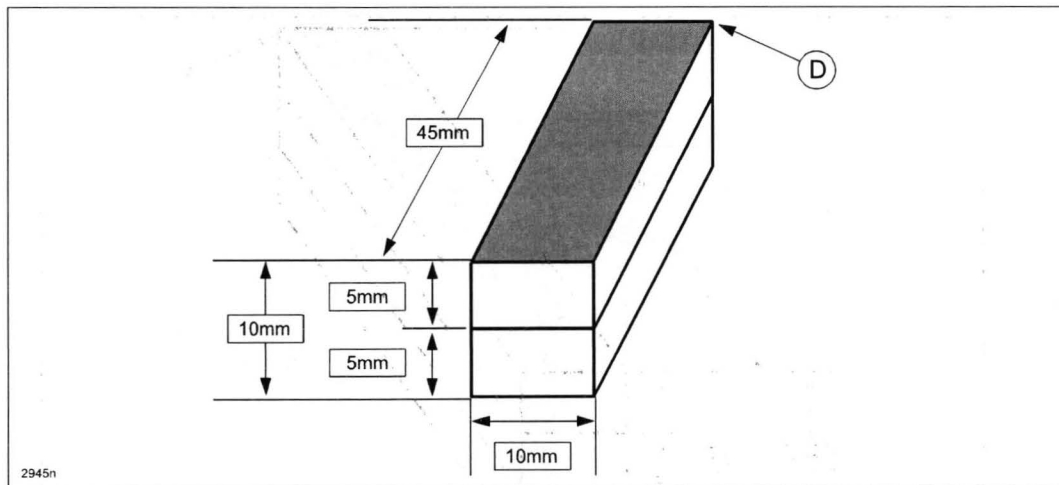

Piece	Sheet Type	Sheet Thickness	Size	Quantity
D	Form Rubber	5mm	10mm X 45mm	2

15. Attach the layered Form Rubber (D) to the back side of front door module panel, positioning one end at the uneven line (A) and along the upper edge of the front door module panel.

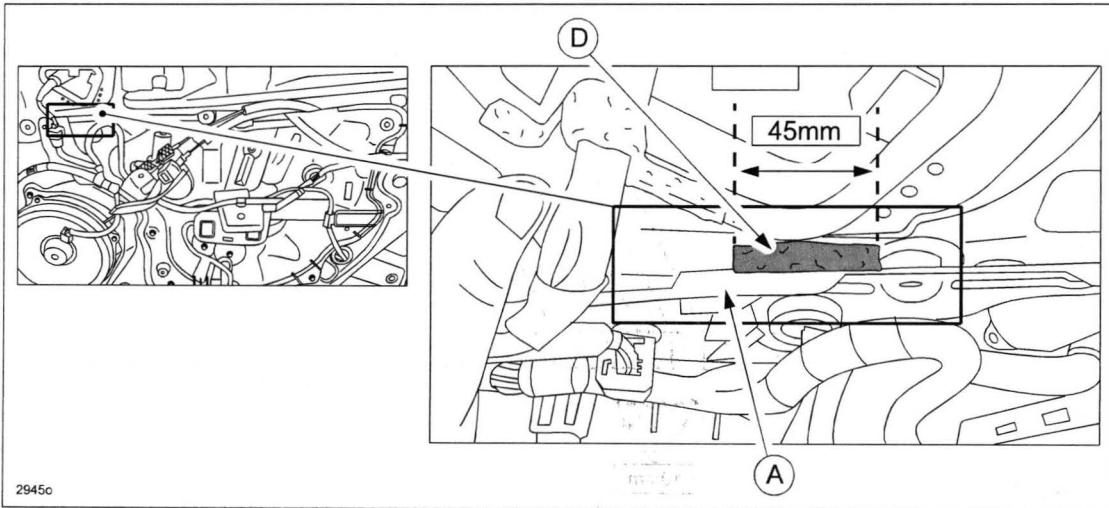

16. Install fixing screws (2.0-3.0 Nm) and fasteners.

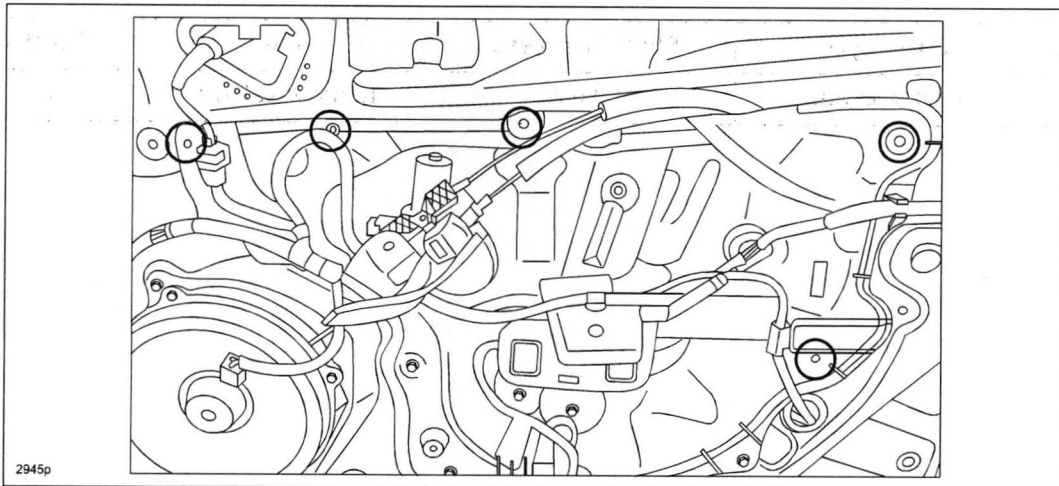

17. Select a 10mm thickness sheet of Urethane Pad (B) from the "Noise Repair Kit K001 W0 225". Cut 3 pieces as shown below.

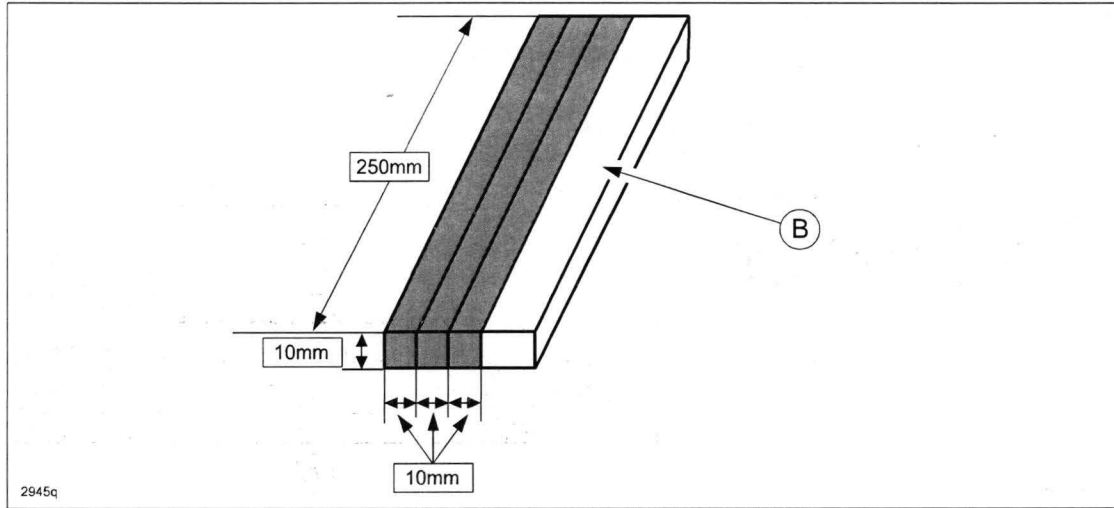

Piece	Sheet Type	Sheet Thickness	Size	Quantity
B	Urethane Pad	10mm	10mm X 250mm	3

18. Attach 3 pieces of the cut urethane pad to the back side of front door trim panel edge for the width indicated by the red arrow (A).

NOTE:

- Attach the pads so there is no clearance between the two.
- Cut off the surplus of the last pad.
- Since the pad has already been attached to this portion (B), there is no need to attach it.

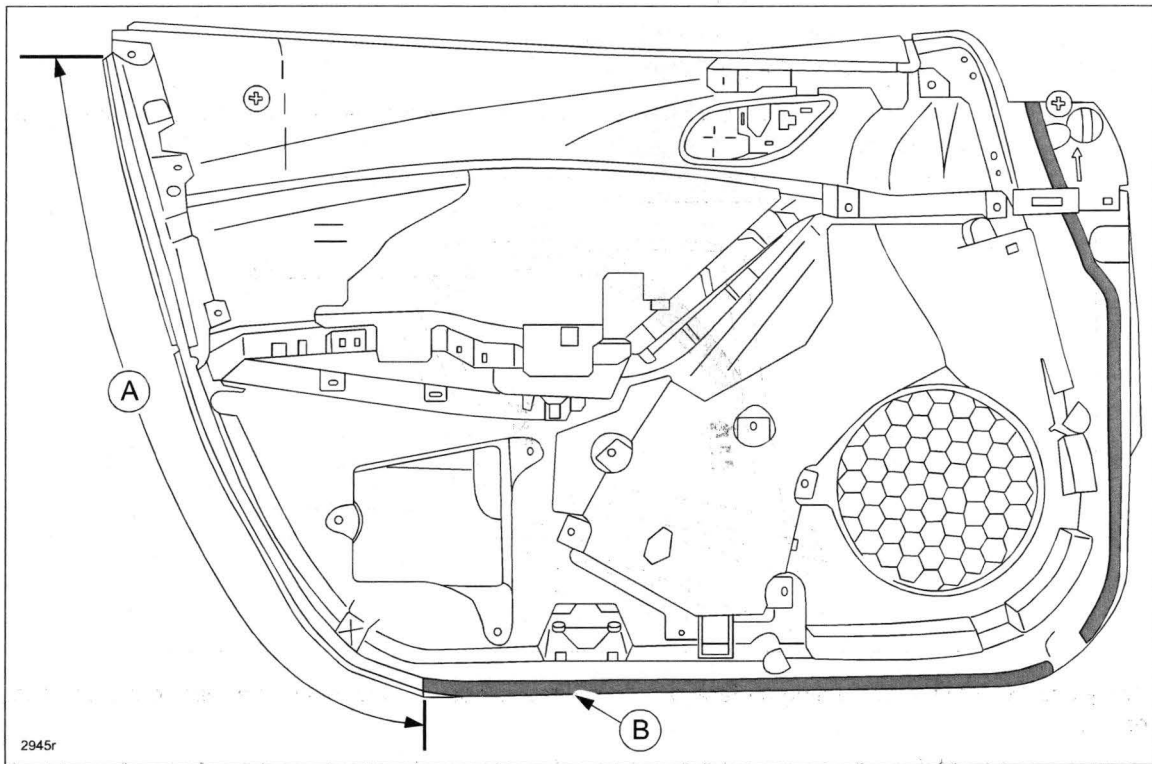

19. Install a new front door trim. Refer to MS3 online or Workshop Manual (section 09-17 FRONT DOOR TRIM REMOVAL/INSTALLATION).

20. Install a new front beltline molding. Refer to MS3 online or Workshop Manual (section 09-16 FRONT BELT-LINE MOLDING REMOVAL/INSTALLATION).

21. Verify repair.

REAR DOOR

22. Fully open the rear door glass.
23. Remove the rear door trim. Refer to MS3 online or Workshop Manual (section 09-17 REAR DOOR TRIM REMOVAL/INSTALLATION).
24. Remove the inner weather strip.
25. Install a new inner weather strip, and then slide it until it contacts the rear glass run channel.
26. Remove the rear beltline molding. Refer to MS3 online or Workshop Manual (section 09-17 REAR BELT-LINE MOLDING REMOVAL/INSTALLATION).
27. Pull both edges of the rear glass run channel (A) and remove it from the rear door the same procedure as the front glass run channel.

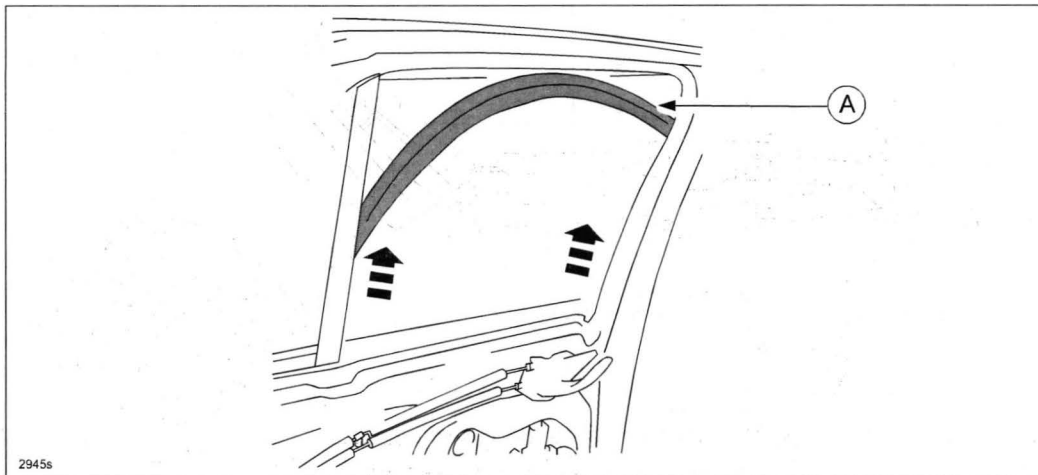

28. Apply soap sud to the contacting surface of the new rear glass run channel to the rear door glass and door panel.
29. Insert both ends of the rear door glass run channel (A) between the rear door glass and door panel, then install the whole rear door glass run channel using the same procedure as the front glass run channel.

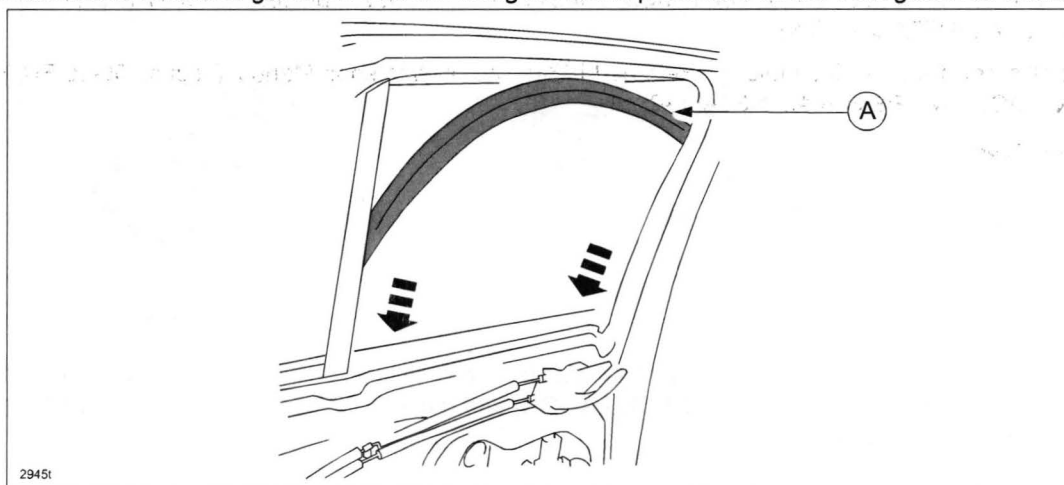

30. Replace the front sash molding. Refer to MS3 online or Workshop Manual (section 09-16 REAR SASH MOLDING REMOVAL) and (section 09-16 REAR SASH MOLDING INSTALLATION).

31. Prepare 1 set of 2 pieces cut Form Rubber C 20mm X 40mm size in layer as shown.

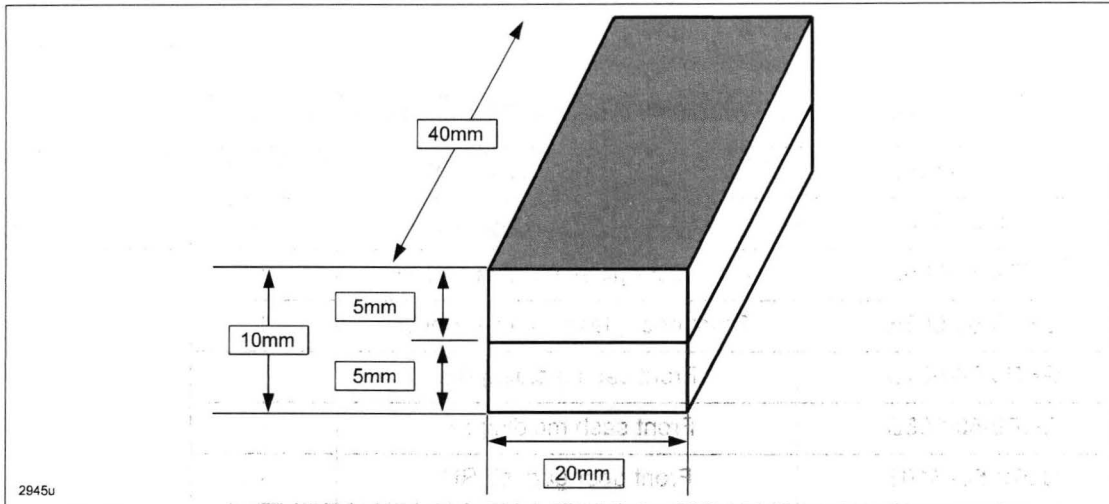

Piece	Sheet Type	Sheet Thickness	Size	Quantity
C	Form Rubber	5mm	20mm X 40mm	2

32. Attach the Form Rubber C to the back side of rear door module panel, positioning one end at the edge of the rear door trim as shown.

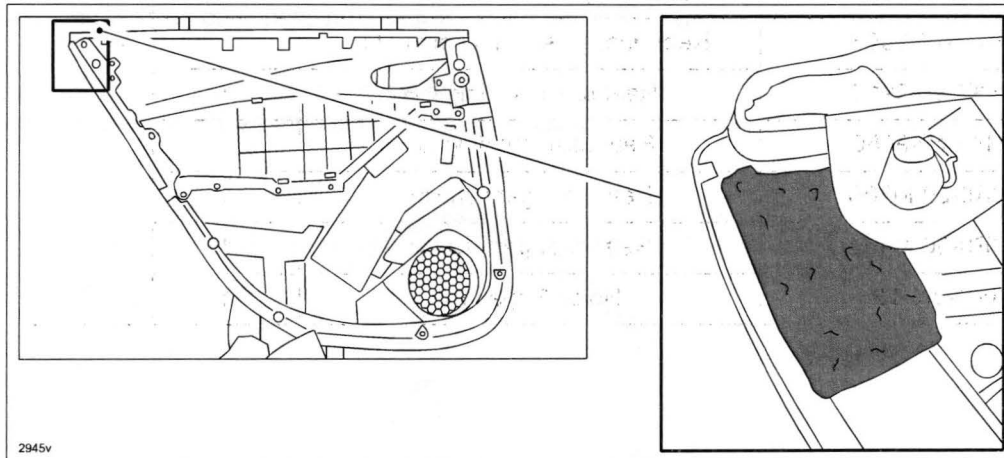

33. Install a new rear door trim and rear beltline molding. Refer to MS3 online or Workshop Manual (section 09-17 REAR DOOR TRIM REMOVAL/INSTALLATION) and (section 09-17 REAR BELTLINE MOLDING REMOVAL/INSTALLATION).

34. Verify repair.

PART(S) INFORMATION

Part Number	Description	Qty.	Notes
GHP9-58-821E	Inner weather strip RH	1	Repair Procedure A
GHP9-59-821E	Inner weather strip LH	1	
GHP9-50-640D	Front beltline molding RH	1	
GHP9-50-650D	Front beltline molding LH	1	
GHP9-58-605H	Front door glass run channel RH	1	Repair Procedure B
GHP9-59-605H	Front door glass run channel LH	1	
GHP9-50-981D	Front sash molding RH	1	
GHP9-50-985D	Front sash molding LH	1	
GJR9-50-M10B	Front door garnish RH	1	
GJR9-50-M20B	Front door garnish LH	1	
GHK1-50-660D	Rear beltline molding RH	1	
GHK1-50-670D	Rear beltline molding LH	1	
GHK1-72-821D	Rear Inner weather strip RH	1	
GHK1-73-821D	Rear Inner weather strip LH	1	
GHK1-72-605H	Rear door glass run channel RH	1	
GHK1-73-605H	Rear door glass run channel LH	1	
GHK1-50-991C	Rear sash molding RH	1	
GHK1-50-995C	Rear sash molding LH	1	
GJR9-50-M30B	Rear door garnish RH	1	
GJR9-50-M40B	Rear door garnish LH	1	
K001-W0-225	Noise Repair Kit	1	

WARRANTY INFORMATION

NOTE:

- This warranty information applies only to verified customer complaints on vehicles eligible for warranty repair.
- This repair will be covered under Mazda's New Vehicle Limited Warranty term.
- Additional diagnostic time cannot be claimed for this repair.

Warranty Type	A
Symptom Code	82
Damage Code	9E
Part Number Main Cause	7777-SP-J50
Quantity	0
Operation Number / Labor Hours:	XXK87ARX / 0.5Hrs Repair procedure A (one side) XXK87CRX / 0.6Hrs Repair procedure A(both sides) XXK87ERX / 1.6Hrs Repair procedure A &B(one side) XXK87GRX / 2.9Hrs Repair procedure A&B(both sides) XXK87HRX / 1.8Hrs Repair procedure A(both sides)&B(one side)

NOTE: Do not claim the noise repair kit (P/N K001-W0-225) as a related part. The amount of fabric used for this repair is included in the labor allowance.