

Service Bulletin

Mazda North American Operations
Irvine, CA 92618-2922



© 2014 Mazda Motor of America, Inc.

| | |
|---|--------------------------------|
| Subject: HOOD VIBRATION WHILE DRIVING AT HIGHWAY SPEED | Bulletin No: 09-028/14 |
| | Last Issued: 06/27/2014 |

BULLETIN NOTE

- This bulletin supersedes the previous bulletin 09-036/13, issued on 12/10/13 and 09-029/12, issued on 07/27/12. The WARRANTY INFORMATION has been revised.
- Changes are noted below in Red beside the change bar.

APPLICABLE MODEL(S)/VINS

2013-2014 CX-5 vehicles with VINs lower than JM3KE*****387092 (produced before September 1, 2013)

DESCRIPTION

Some vehicles may exhibit a condition where the hood vibrates when driving at speeds of 110 Km/h (68 mph) or more.

The amount of sealant used to fill in the space between the inner frame and outer panel at the bottom area of the hood is insufficient. If the sealant detaches (as shown below on the left), it may cause the hood to vibrate. The amount of sealant has been increased during vehicle production and the preload force of the cowl grill seal has been increased to eliminate the concern.

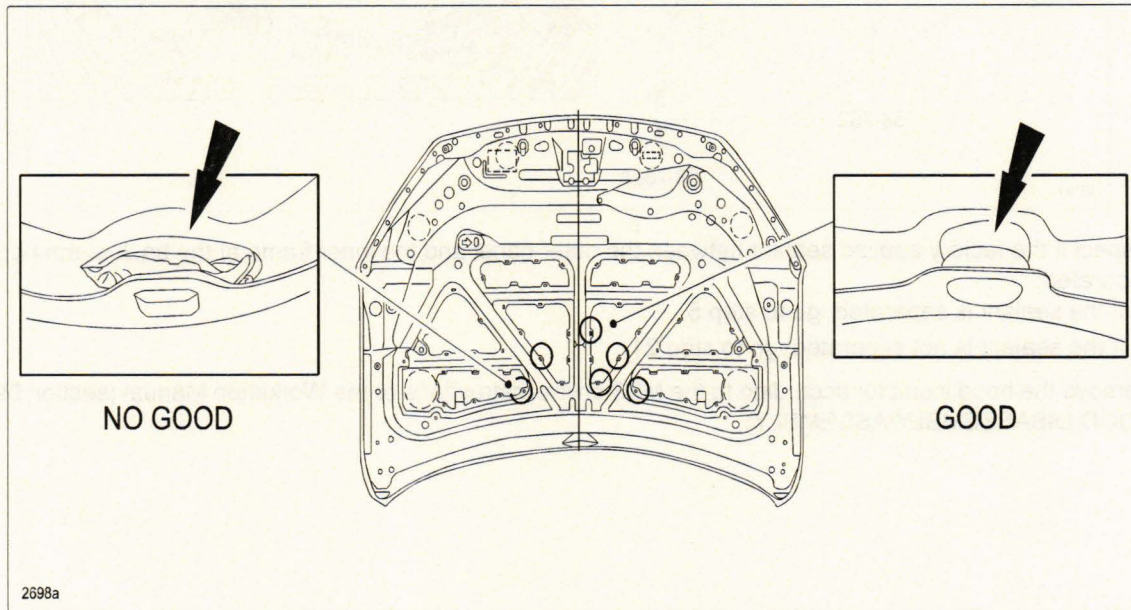

Customers having this concern should have their vehicle repaired using the following repair procedure.

CONSUMER NOTICE: The information and instructions in this bulletin are intended for use by skilled technicians. Mazda technicians utilize the proper tools/equipment and take training to correctly and safely maintain Mazda vehicles. These instructions should not be performed by "do-it-yourselfers." Customers should not assume this bulletin applies to their vehicle or that their vehicle will develop the described concern. To determine if the information applies, customers should contact their nearest authorized Mazda dealership. Mazda North American Operations reserves the right to alter the specifications and contents of this bulletin without obligation or advance notice. All rights reserved. No part of this bulletin may be reproduced in any form or by any means, electronic or mechanical—including photocopying and recording and the use of any kind of information storage and retrieval system—without permission in writing.

REPAIR PROCEDURE

The cowl grill seal will be replaced with a modified part, additional dampening material may be applied between the hood's inner frame and outer panel and the hood height may be adjusted to apply additional tension.

NOTE:

- This repair should be performed by a qualified technician or body shop.
 - DO NOT use any other products for this repair, such as panel bonding glue, which is too strong for this type of repair.
1. Verify the customer concern.
 2. Open the hood and secure it with the support rod.
 3. Replace the cowl grill seal (A) with a modified one with increased preload force.

NOTE: The cowl grill seal is attached to the cowl grill with 15 clips.

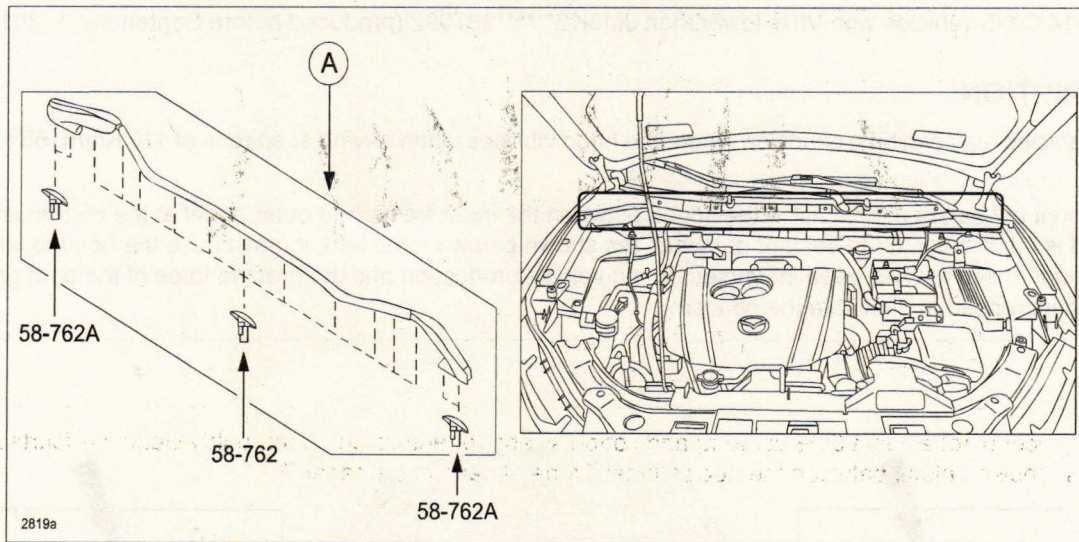

4. Inspect if the factory applied sealant between the outer panel and the inner frame at the back of the hood is separated.
 - If the sealant is separated, go to step 5.
 - If the sealant is not separated, go to step 21.
5. Remove the hood insulator according to the MS3 online instructions or the Workshop Manual (section 09-10 HOOD DISASSEMBLY/ASSEMBLY).

6. Confirm the ten (10) original sealant spots at the bottom area of the hood.

NOTE:

- Additional dampening material will be applied **between** these ten (10) original sealant spots.
- It is not necessary to apply dampening material to other areas of the hood. Even if the original sealant has become detached, it will have no influence on the hood vibration concern.

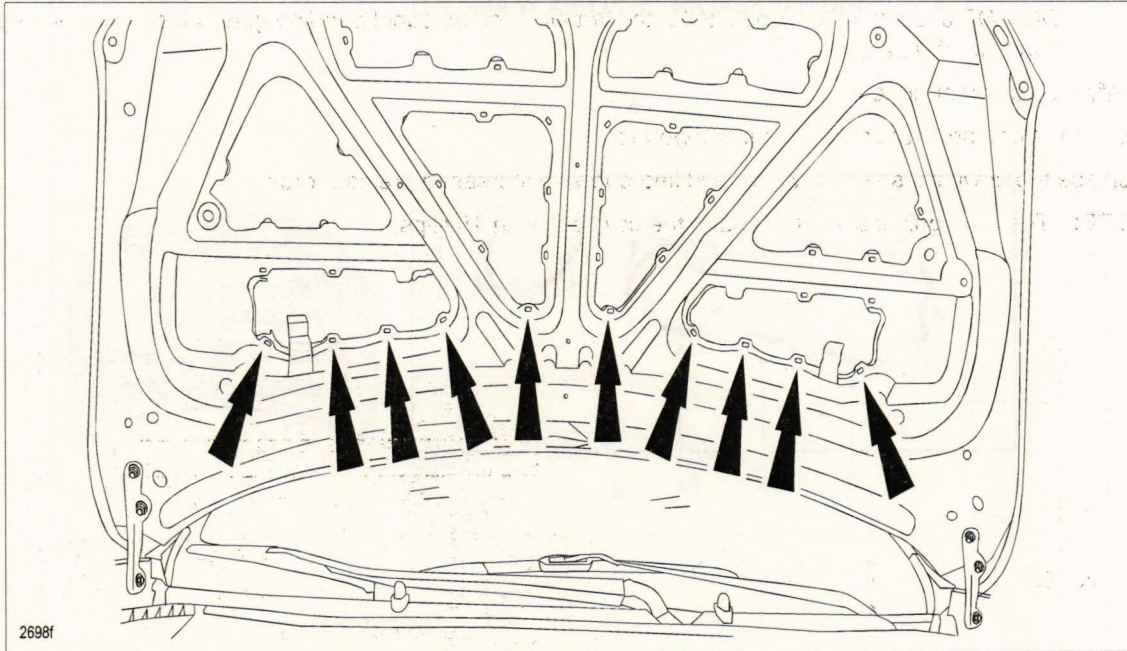

7. Using alcohol (of at least 50% content) and cotton swabs (or equivalent), thoroughly clean the fourteen (14) areas (shown below) between the hood's inner frame (A) and outer panel (B).

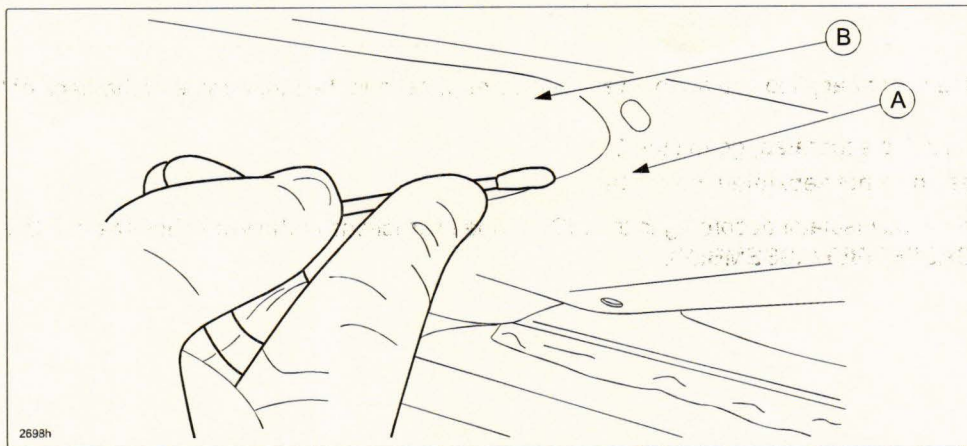

NOTE: There are seven (7) areas on the left side of the hood and seven (7) areas on the right side of the hood to be cleaned (left side shown below).

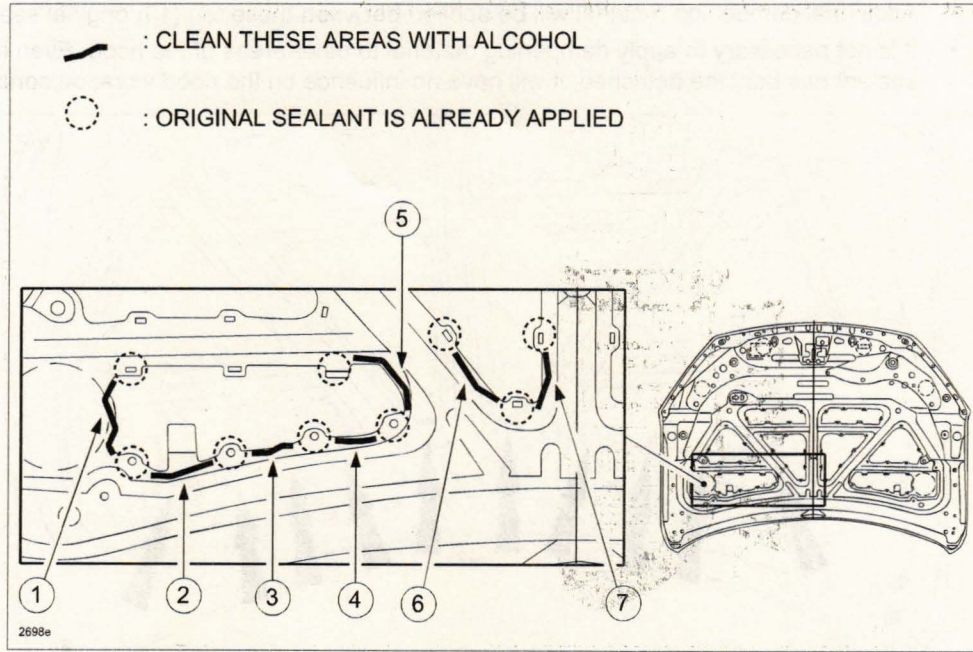

8. Locally obtain the following materials to perform the repair:
- Duramix NVH Dampening Material (04274); (includes two (2) mixing nozzles)
 - Mixpac Applicator Gun (08117) OR 3M Cartridge Applicator Gun (08571)

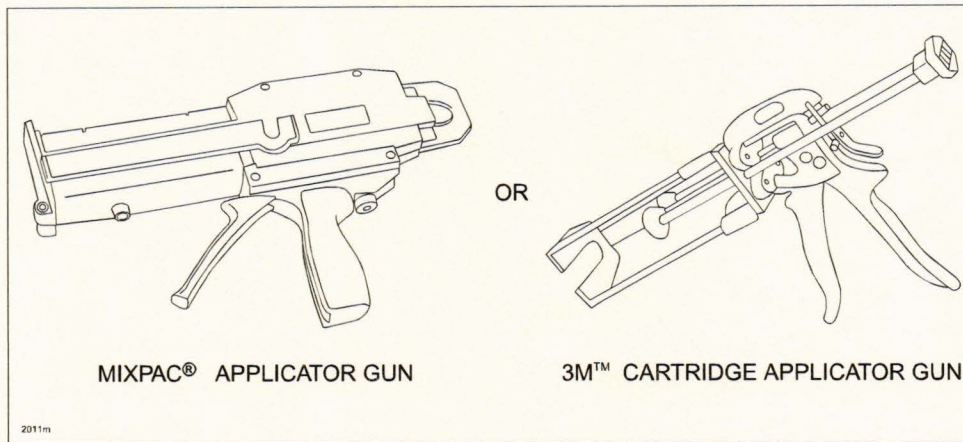
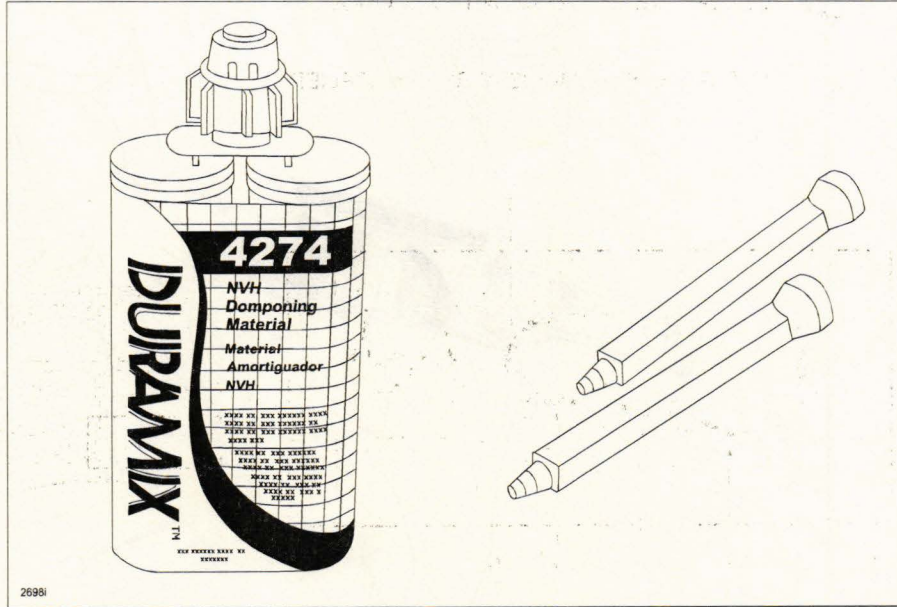

NOTE: Either applicator gun can be used, however, the 3M cartridge applicator gun is normally less expensive than the Mixpac applicator gun.

9. Insert Duramix NVH Dampening Material (04274) into applicator gun and remove the cap and insert.

NOTE: Do not discard the cap or insert.

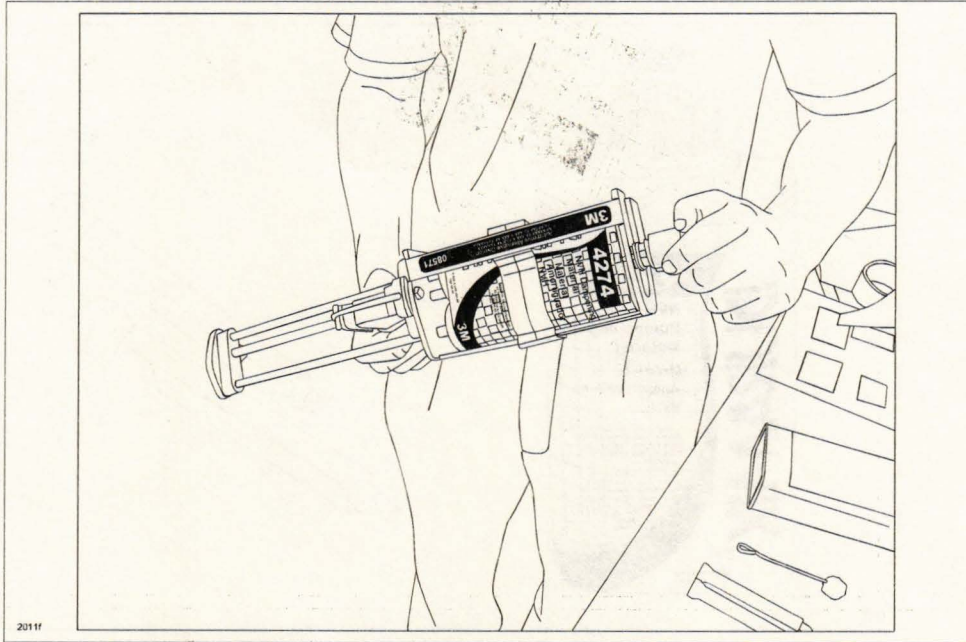

10. Begin squeezing the applicator gun trigger until clear dampening material starts to come out of one side.

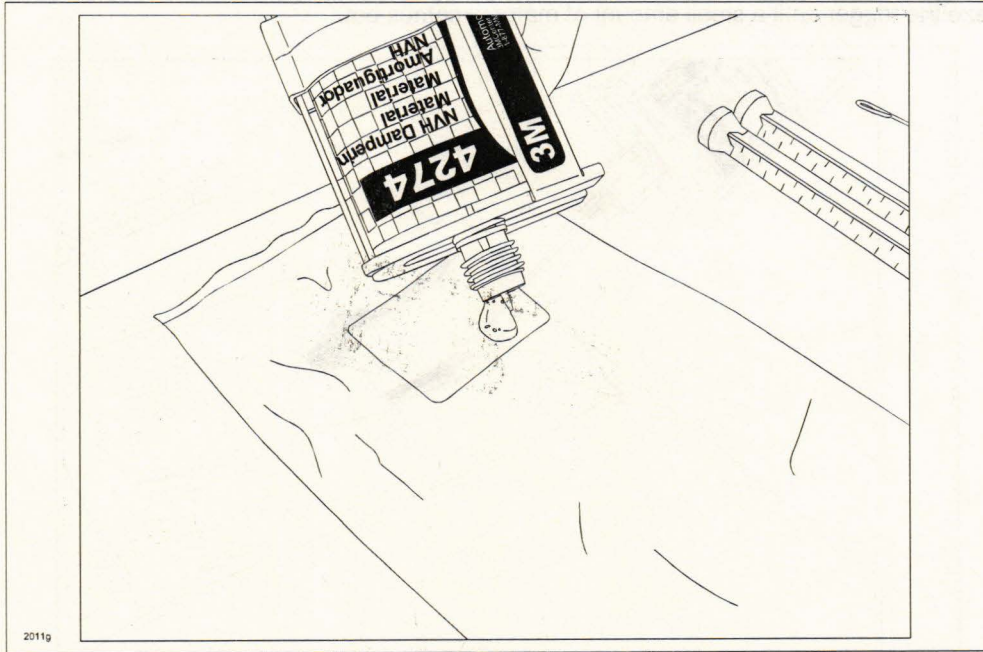

11. Continue squeezing the trigger until dampening material (A) and hardener (B) come out equally.

NOTE: This ensures dampening material and hardener are correctly mixed and will harden properly.

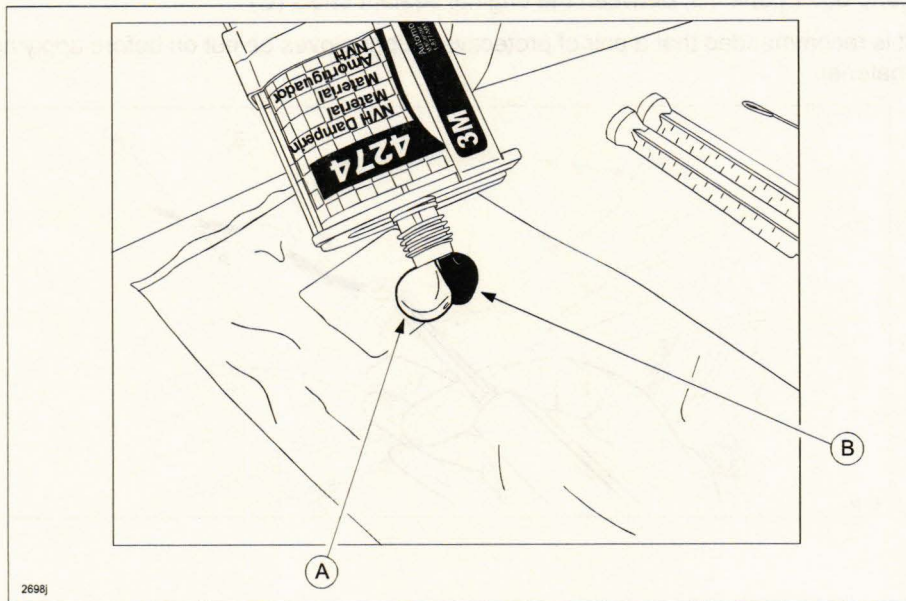

12. Insert the mixing nozzle onto the tip of the dampening material, then screw in the removed cap and tighten.
13. Squeeze the trigger until a small amount of material comes out.

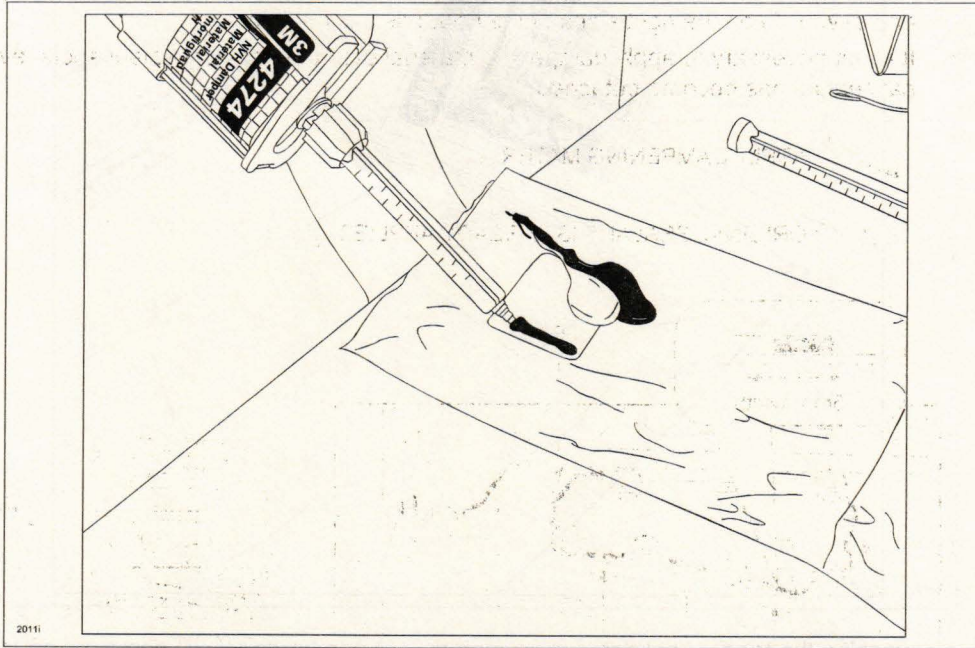

14. Apply a 5 mm wide bead of dampening material by pushing and filling it into the space between the inner frame (A) and outer panel (B) between the original sealant spots (C).

NOTE: It is recommended that a pair of protective rubber gloves be put on before applying the dampening material.

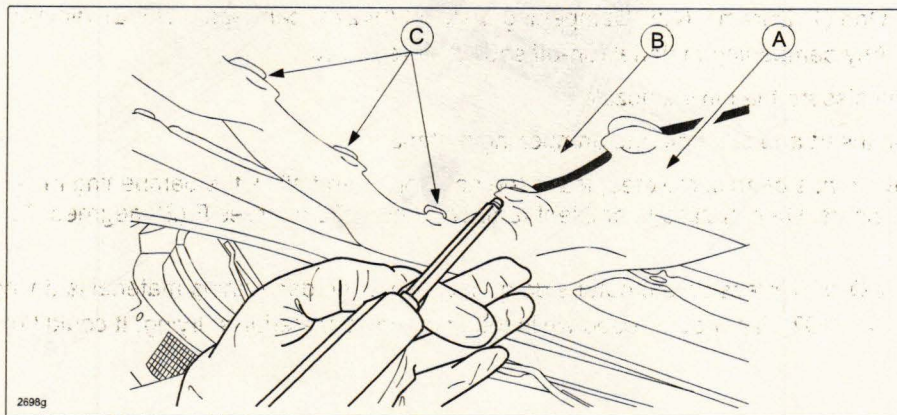

NOTE:

- Ensure the dampening material adheres to the inner frame and outer panel.
- Dampening material must be applied to a total of fourteen (14) locations, (seven (7) on the left and seven (7) on the right sides of the hood) as shown below.
- It is not necessary to apply dampening material over the original sealant spots, even if the original sealant has become detached.

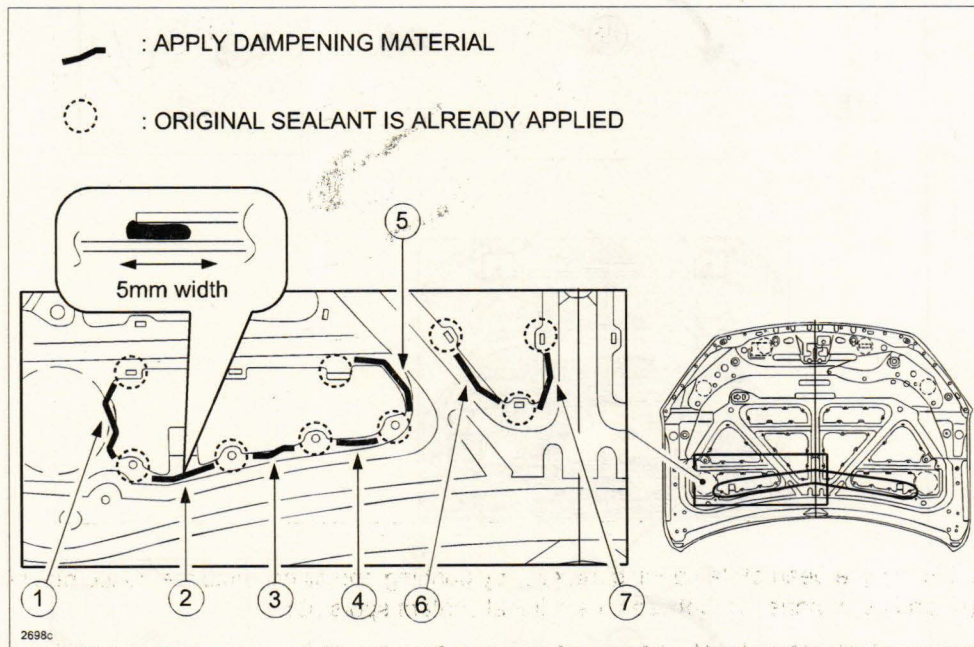

NOTE:

- One (1) Duramix NVH Dampening Material (04274) can repair two (2) vehicles.
- Any dampening material run-off should be removed.

15. Remove and discard the mixing nozzle.

16. Reinstall the insert and cap onto the dampening material.

17. Once the repair has been completed, leave the hood open and allow the dampening material to dry for at least six (6) hours when applied in ambient temperatures of 70 degrees F (21 degrees C).

NOTE:

- DO NOT press on the outer side of hood while the dampening material is drying.
- DO NOT slam hood closed while the dampening material is drying. It could break the bond.

18. Adjust the hood height by turning the rubber stoppers on the hood (2 stoppers) and body side (2 stoppers).
- Hood: Turn both hood side rubber stopper protrusions (A) 1/4 turn counterclockwise (B).
 - Body: Turn both body side rubber stopper protrusions (C) 1/2 turn counterclockwise (D).

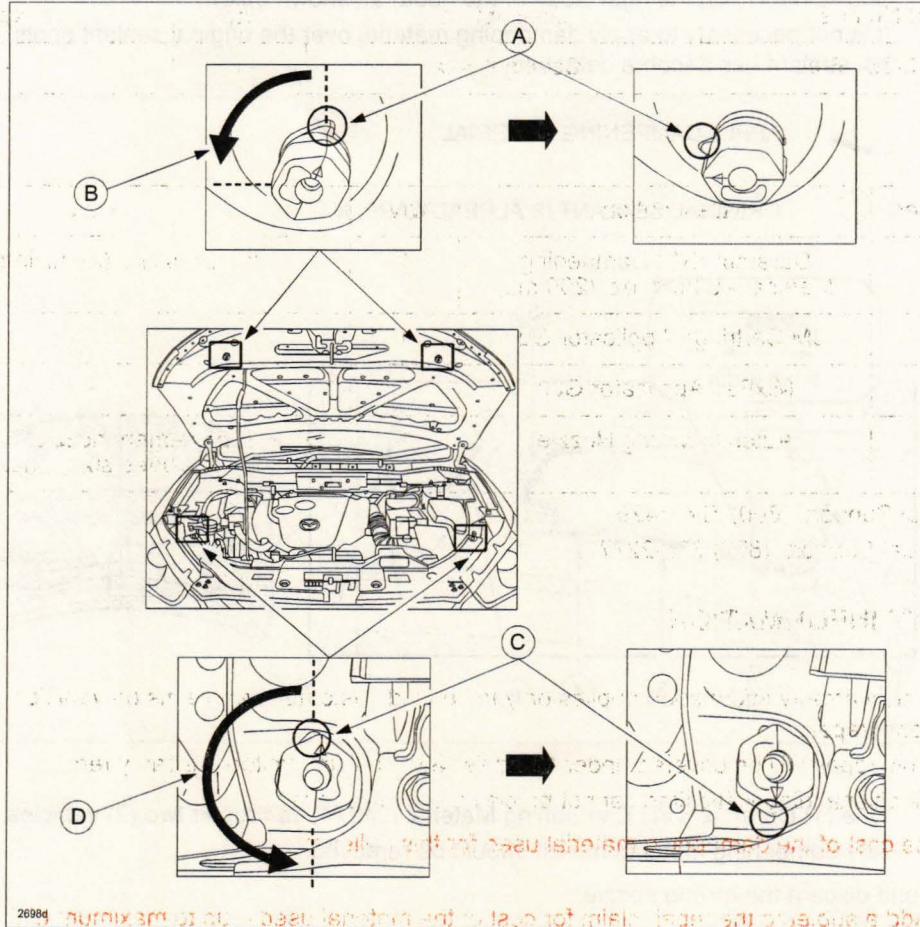

19. After the dampening material has completely dried, close the hood and check the clearance between the hood and both front fenders according to the Body Shop Manual [CONSTRUCTION STANDARD VALUES].
20. Reinstall the hood insulator according to the MS3 online instructions or the Workshop Manual (section 09-10 HOOD DISASSEMBLY/ASSEMBLY).
21. Road test the vehicle to verify the hood vibration has been eliminated.

| | |
|--|--------------------------------|
| Bulletin No: 09-028/14 © 2014 Mazda Motor of America, Inc. | Last Issued: 06/27/2014 |
|--|--------------------------------|

PART(S) INFORMATION

| Part Number | Description | Qty. | Notes |
|--------------|-----------------|------|-------|
| KD53-56-760A | Cowl grill seal | 1 | --- |

| Part Number | Description | Qty. | Notes |
|-------------|---|------|--|
| 04274 | Duramix NVH Dampening Material - 6.25 fl. oz. (200 ml.) | 1 | Includes two (2) mixing nozzles |
| 08571 | 3M Cartridge Applicator Gun | 1 | --- |
| 08117 | MixPac Applicator Gun | 1 | --- |
| 08193 | Automix Mixing Nozzle | 1 | Order replacement nozzles as necessary. Includes six (6) nozzles |

- 3M General Support: (800) 524-6429
- 3M Technical Support: (877) 666-2277

WARRANTY INFORMATION

NOTE:

- This warranty information applies only to verified customer complaints on vehicles eligible for warranty repair.
- This repair will be covered under Mazda's New Vehicle Limited Warranty term.
- Additional diagnostic time cannot be claimed for this repair.

To recover the cost of the dampening material used for this bulletin:

NOTE:

- Add a sublet to the repair claim for cost of the material used – up to maximum of \$40.00.
- Sublet Type Code use "H9" – Locally Procured Part.
- Sublet Description enter "Dampening Material".
- Attach copy of the purchase invoice in accordance with warranty sublet policy.

| | |
|---------------------------------|--|
| Warranty Type | A |
| Symptom Code | 83 |
| Damage Code | 97 |
| Part Number Main Cause | KD53-56-760A (Cowl grill seal) |
| Quantity | 1 |
| Operation Number / Labor Hours: | XXK18XRX / 0.2 Hrs. (Cowl grill seal, body sealant inspection only) XXK19XRX / 0.3 Hrs. (Cowl grill seal, body sealant application) |

NOTE: One (1) Duramix NVH Dampening Material (04274) can repair two (2) vehicles.