

© 2014 Mazda Motor of America, Inc.

Subject:

DRIVER-SIDE POWER DOOR MIRROR VIBRATION

Bulletin No: 09-026/14

Last Issued: 06/10/2014

BULLETIN NOTE

- This bulletin supersedes the previous bulletin 09-002/13 issued 02/26/13, 10/24/13. The **APPLICABLE MODEL(S)/VINS, DESCRIPTION and REPAIR PROCEDURE** have been revised.
- Changes are noted below in Red beside the change bar.

APPLICABLE MODEL(S)/VINS

2013-2015 CX-5 vehicles with VINS lower than JM3KE*****465579 (produced before April 1, 2014)

DESCRIPTION

Some vehicles may exhibit a vibration from the driver-side power door mirror glass when the vehicle is driven at high speeds.

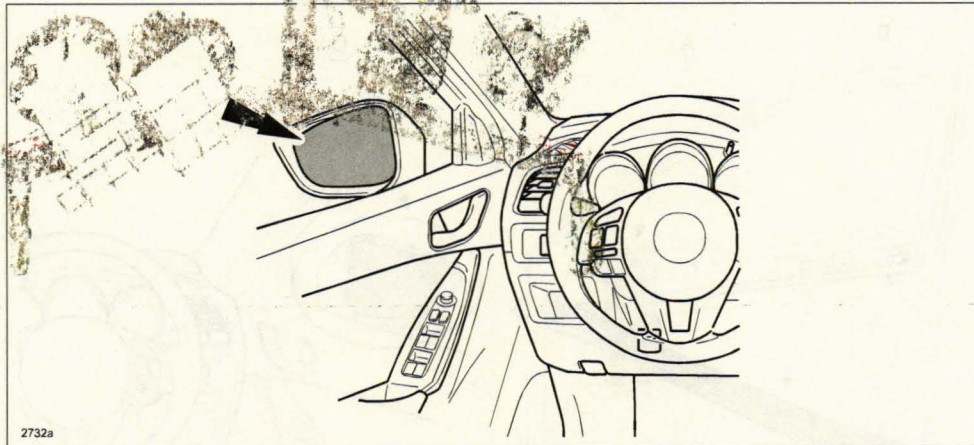

This concern may be due to a lack of rigidity of the mirror base so the mirror vibrates when it receives vehicle vibration or wind pressure.

An additional reinforcement has been installed inside the door to increase the door panel strength where the door mirror is mounted. Also, the door mirror shape has been changed. Both of these modifications have been implemented to eliminate mirror glass vibration concerns.

Customers having this concern should have their vehicle repaired using the following repair procedure.

REPAIR PROCEDURE

Depending on the VIN, perform applicable repairs according to the chart below.

VIN / Prod. Date Range	Applicable Repair	
	Repair A: Installation of outer door mirror reinforcement	Repair B: Replacement of outer door mirror
JM3KE*****000001 - 168884 Produced on or before Nov. 16, 2012	Yes	Yes
JM3KE*****168885 - 465578 Produced between Nov. 16, 2012 and April 1, 2014	No	Yes

Repair A: Install a new reinforcement (A) onto the side impact bar-lower (B) and door panel to increase rigidity of the door panel where the power door mirror is located.

Repair B: Replace the power door mirror (C) with a modified one.

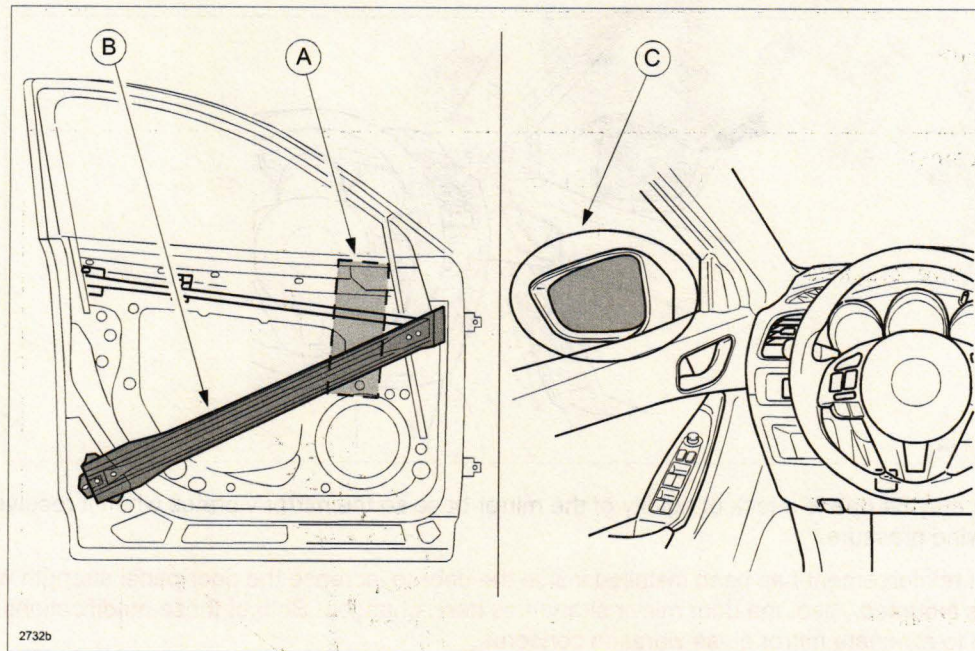

Outline of Repair A:

Upper reinforcement: Tighten the upper reinforcement (A) to the door panel together with the power door mirror with three (3) nuts / bolts.

Lower reinforcement: Attach the lower reinforcement (B) to the side impact bar-lower with two (2) (upper and lower) brackets.

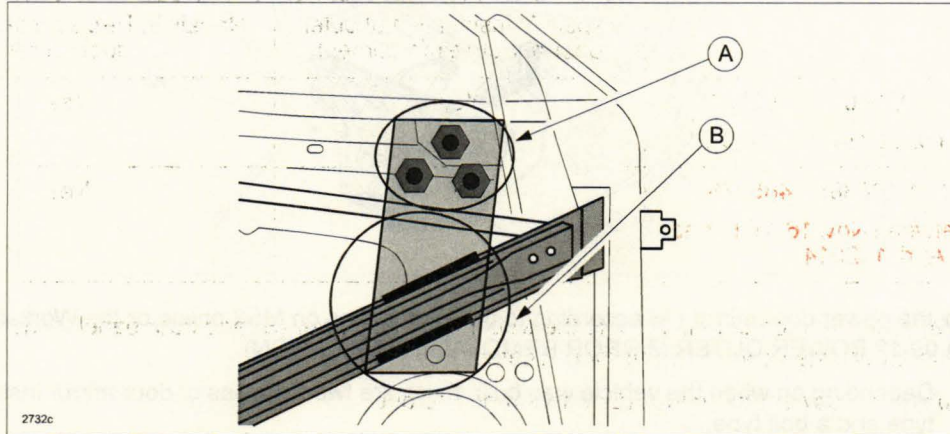

2732c

<cross-section>

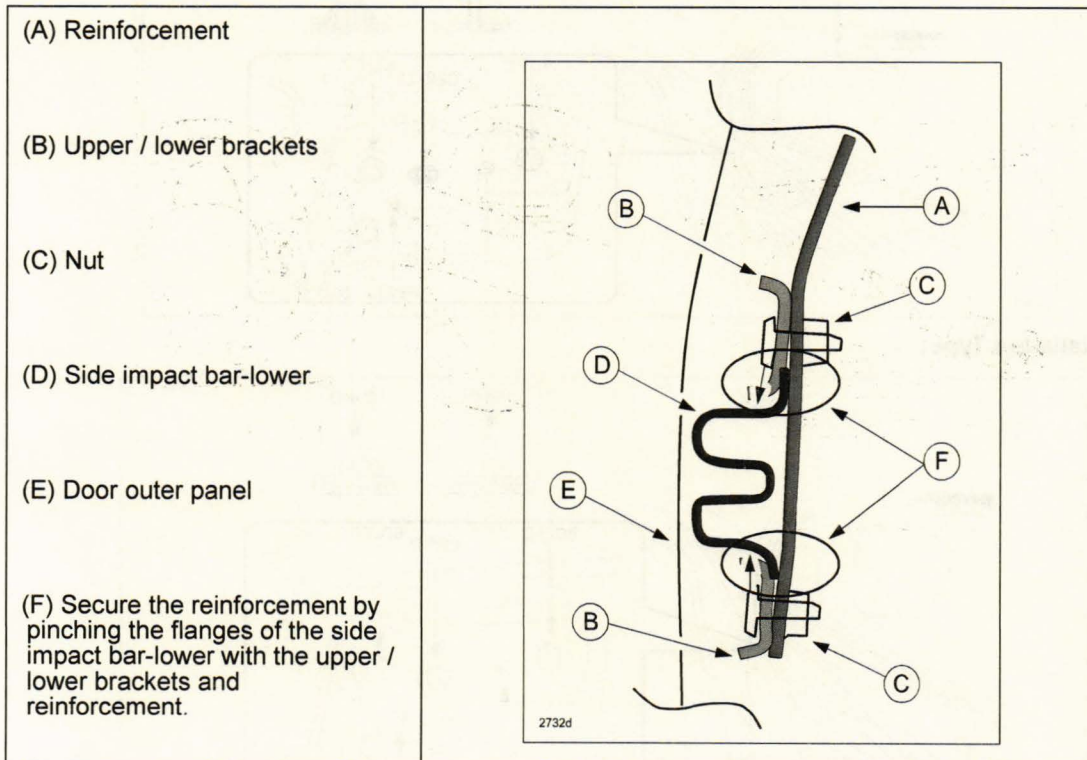

Outline of Repair B:

1. Remove the front door module panel (A) according to the instructions on MS3 online or the Workshop Manual (section 09-11 FRONT DOOR MODULE PANEL REMOVAL/INSTALLATION).

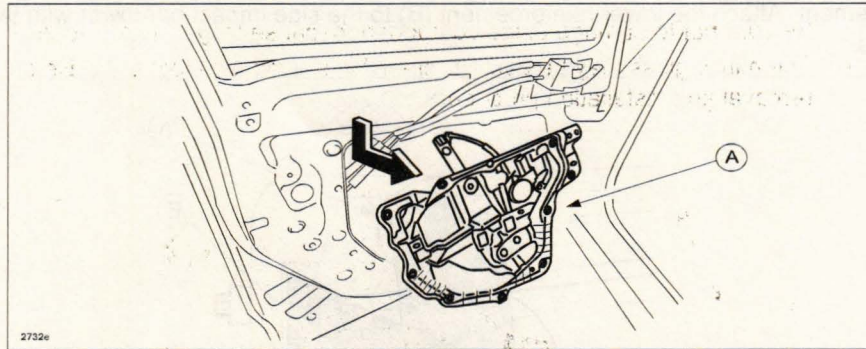

2. Remove the power door mirror (A) according to the instructions on MS3 online or the Workshop Manual (section 09-12 POWER OUTER MIRROR REMOVAL/INSTALLATION).

NOTE: Depending on when the vehicle was built, there are two (2) types of door mirror installations; a nut type and a bolt type.

Nut Installation Type:

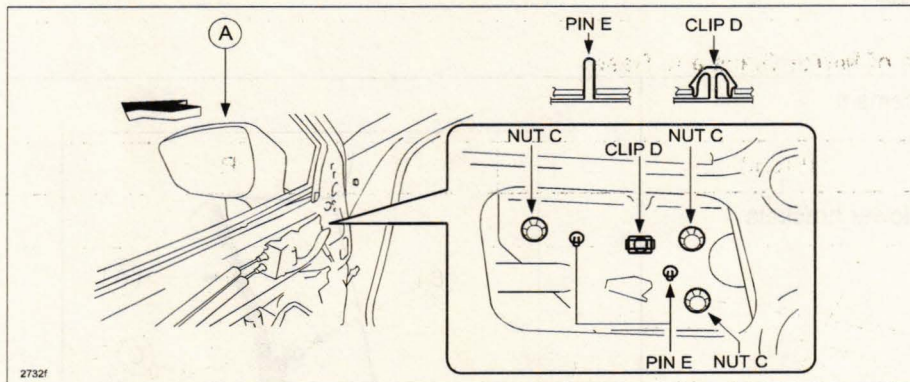

Bolt Installation Type:

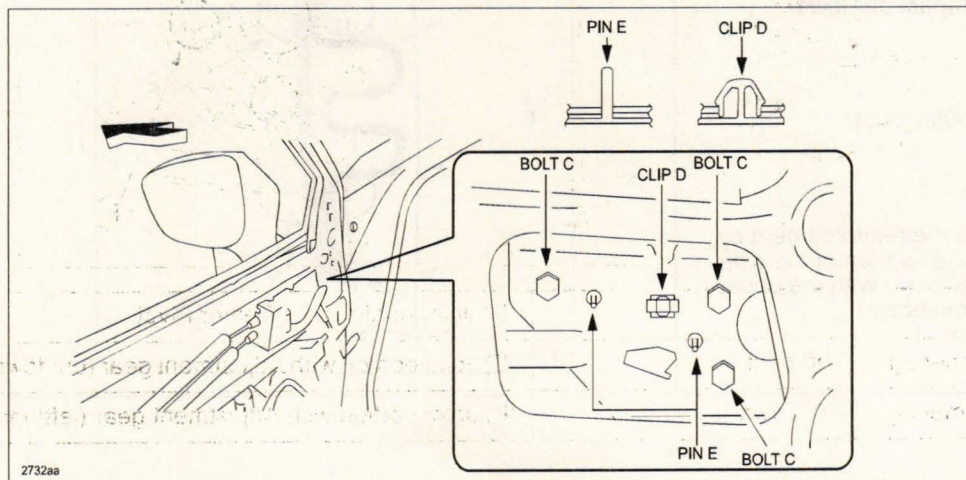

- Remove the mirror glass (A), garnish (B) and side turn lamp (C) from the removed outer door mirror according to the instructions on MS3 online or the Workshop Manual (section 09-12 OUTER MIRROR GARNISH REMOVAL/INSTALLATION) and (section 09-18 SIDE TURN LIGHT REMOVAL/INSTALLATION).

CAUTION:

- Be sure not to damage these component because they will be re-used.
- The mirror glass may be easily broken if it is removed incorrectly. Be sure to follow the removal and installation procedure.

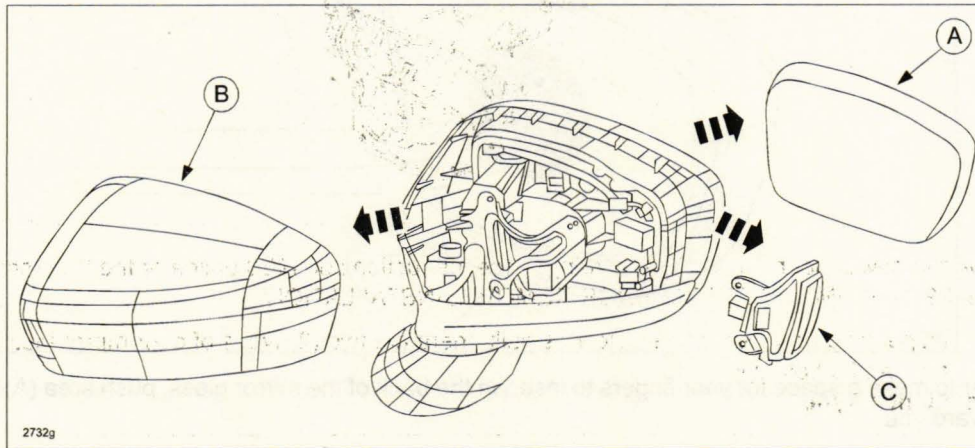

Construction of Mirror Glass and Base:

(Front)	(Rear)
(A) Center pivot	(D) Joint portion with Center Pivot
(B) Adjustment gear (left/right)	(E) Joint portion with Adjustment gear (up/down)
(C) Adjustment gear (up/down)	(F) Joint portion with Adjustment gear (left/right)

Removal of Mirror Glass:

1. In order to make it easier to disconnect the joint portion with the center pivot, heat the center of the mirror glass with a drier to approx. 104-122 degrees F (40-50 degrees C).

CAUTION: Be sure not to use too much heat, otherwise the mirror could become deformed.

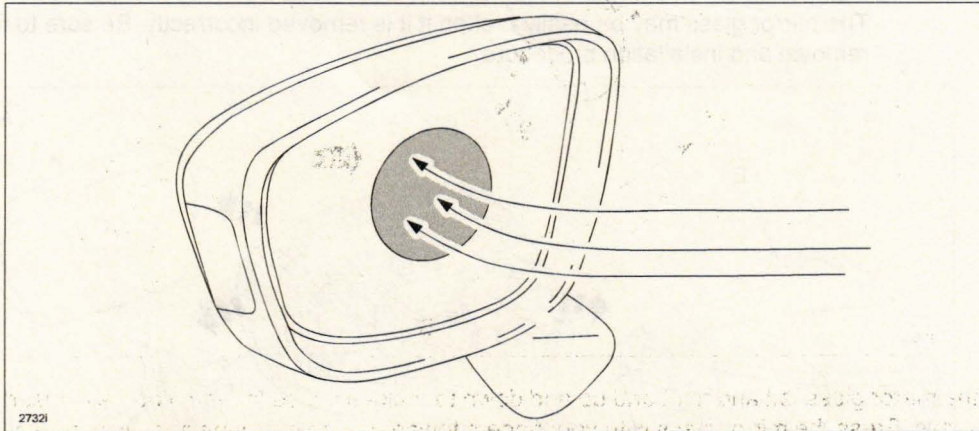

2. In order to make a space for your fingers to insert in the back of the mirror glass, push area (A) to move area (B) toward you.

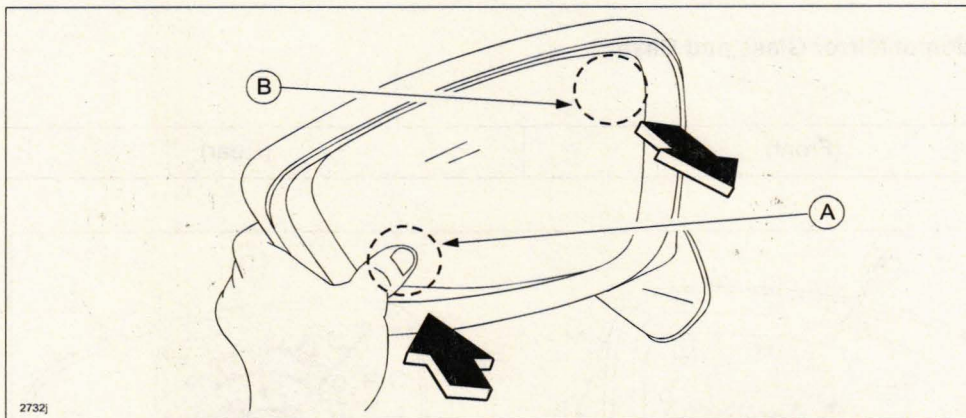

3. Insert your fingers into area (A) between the black plastic base at the back of the mirror glass.

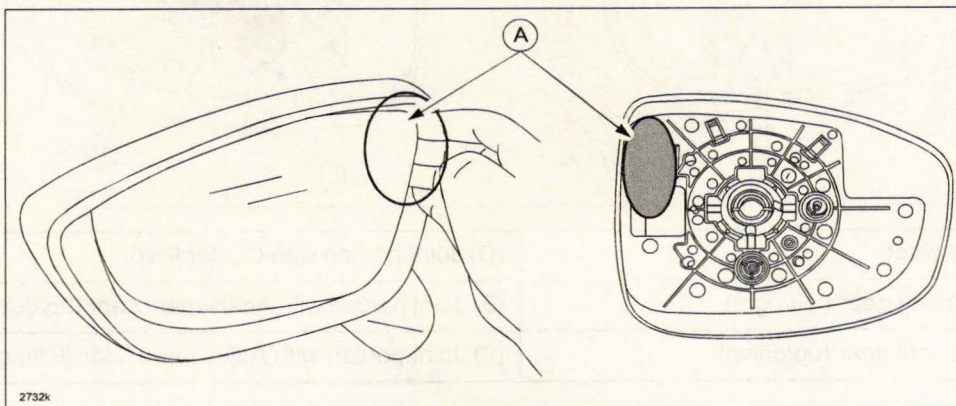

4. Press the black plastic base at the back of mirror glass (A) toward you and carefully disconnect the joint with the center pivot (B).

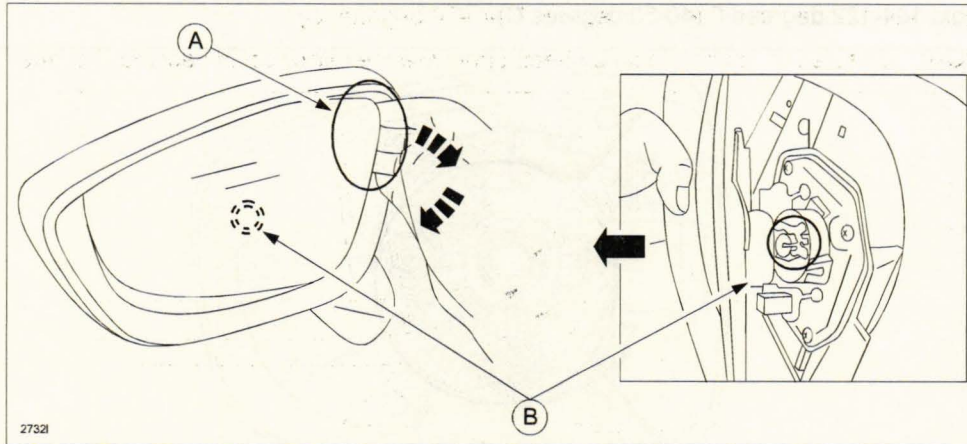

5. Move the mirror glass left and right and up and down to make a space for your fingers to insert in the back of mirror glass. Press the mirror glass with your fingers toward you to disconnect the joint for adjustment gears (A) and (B).

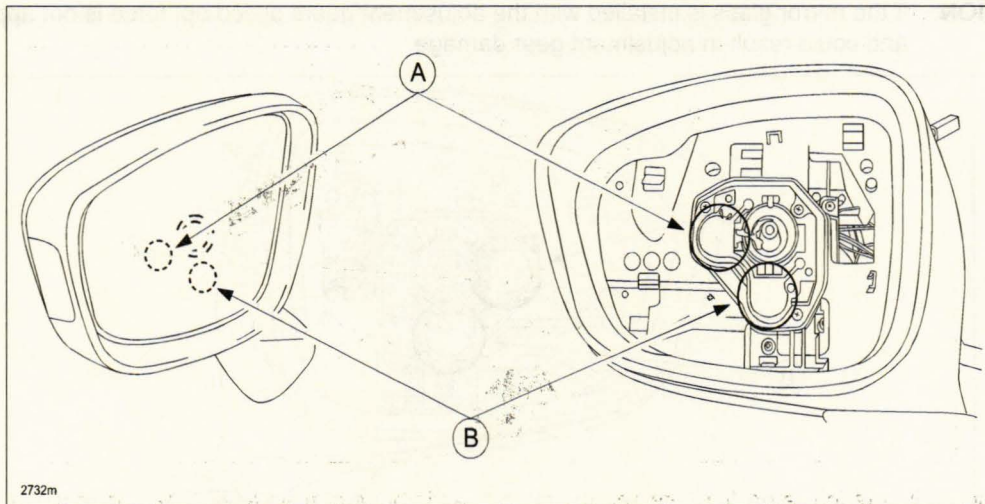

Installation of Mirror Glass:

1. In order to make it easier to connect the joints, heat the plastic base at the back of mirror glass with a drier to approx. 104-122 degrees F (40-50 degrees C).

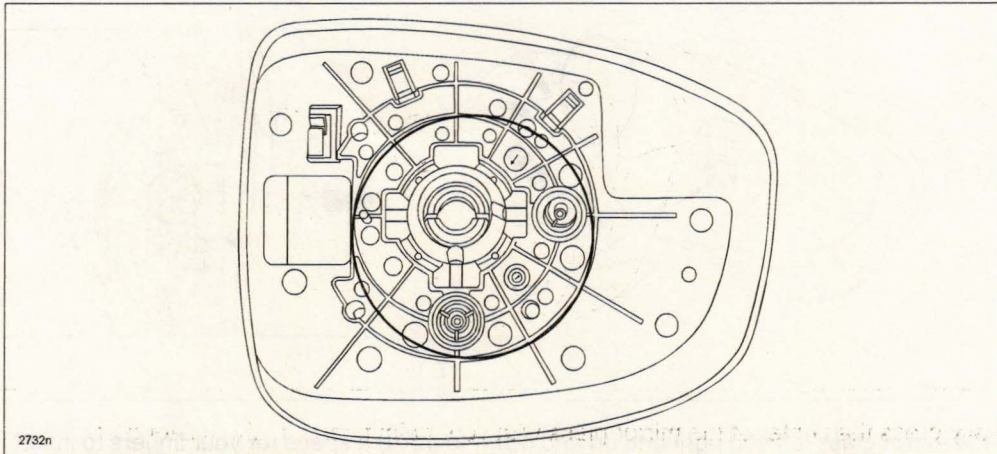

2. Push the adjustment gears (A) and (B) all the way down.

CAUTION: If the mirror glass is installed with the adjustment gears pulled up, force is not applied straight and could result in adjustment gear damage.

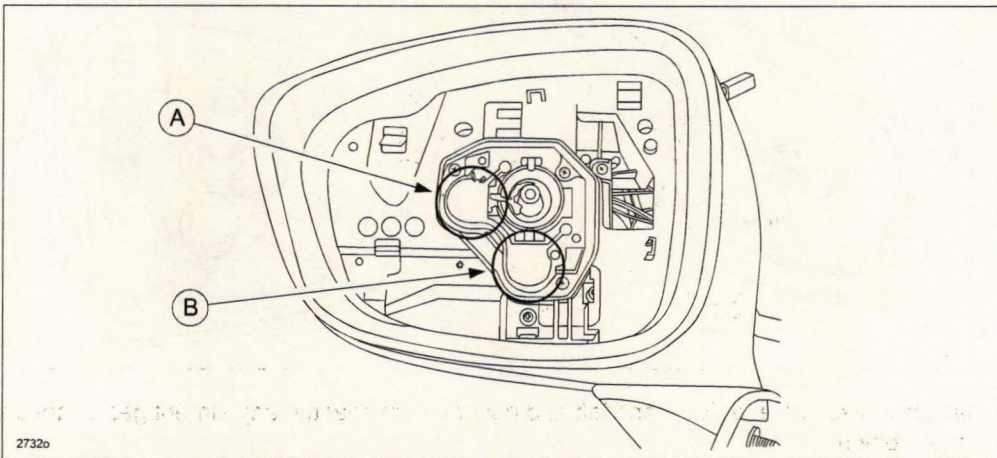

3. Place the mirror glass on the mirror base aligning the location of the center pivot (A).

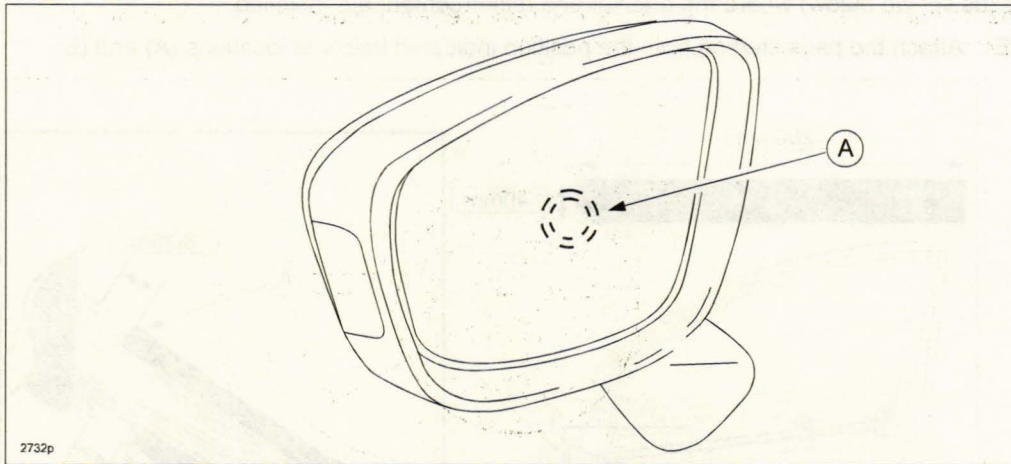

4. Gradually press the center of the mirror glass with your palm to click in the center pivot.
5. Press the areas (A) and (B) of the mirror glass to click in the joint for the adjustment gears.

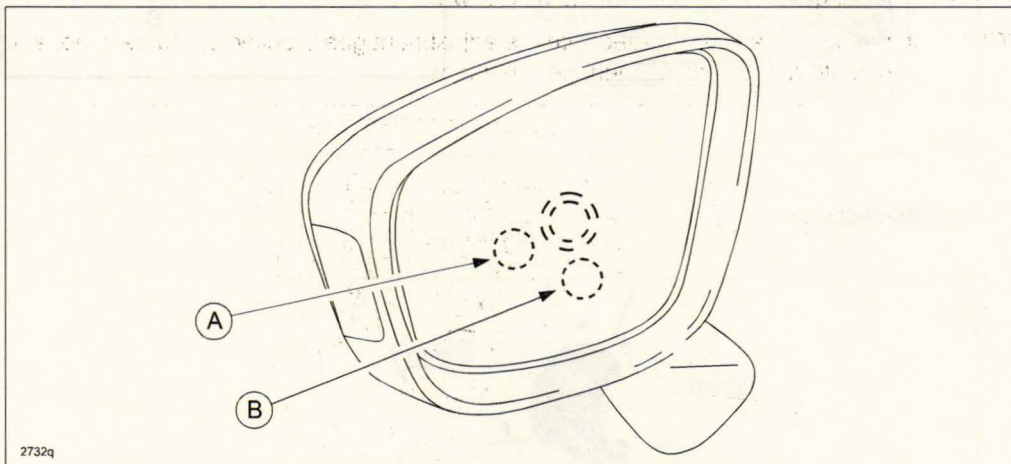

6. Move the mirror glass up and down and left and right to verify that the adjustment gears move smoothly and without any problem.
7. Adjust the mirror glass in the neutral position.
8. Install the removed side turn lamp, garnish and glass onto the new power door mirror.

9. For rust prevention, attach two (2) self-stick pads (200mm x 40mm) to each edge of the side impact bar-lower (as shown below) where the bracket and reinforcement are installed.

NOTE: Attach the pads starting from the position indicated below at locations (A) and (B).

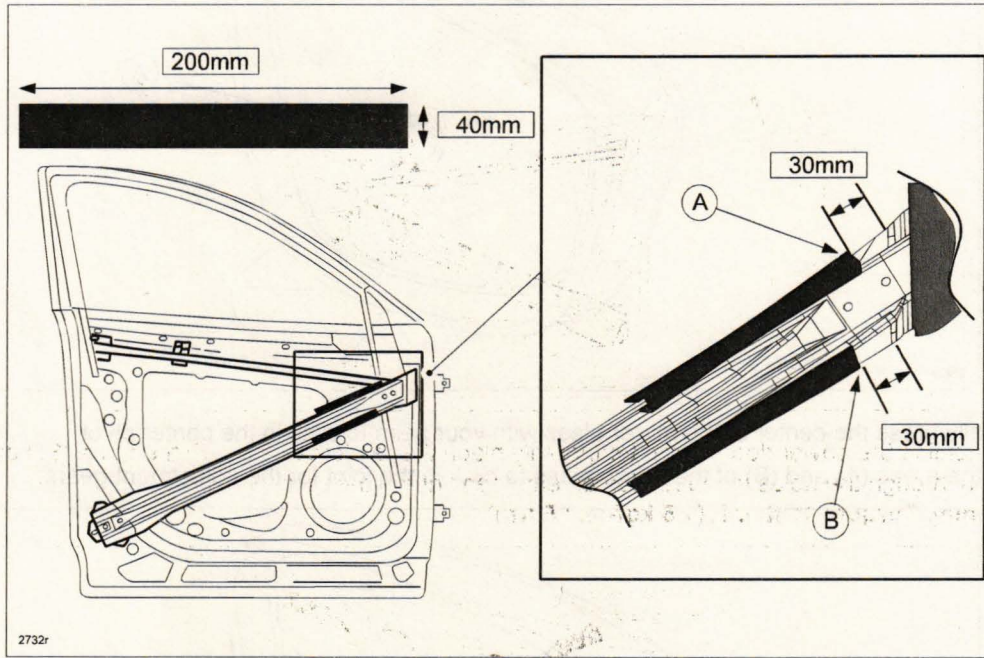

<cross-section>

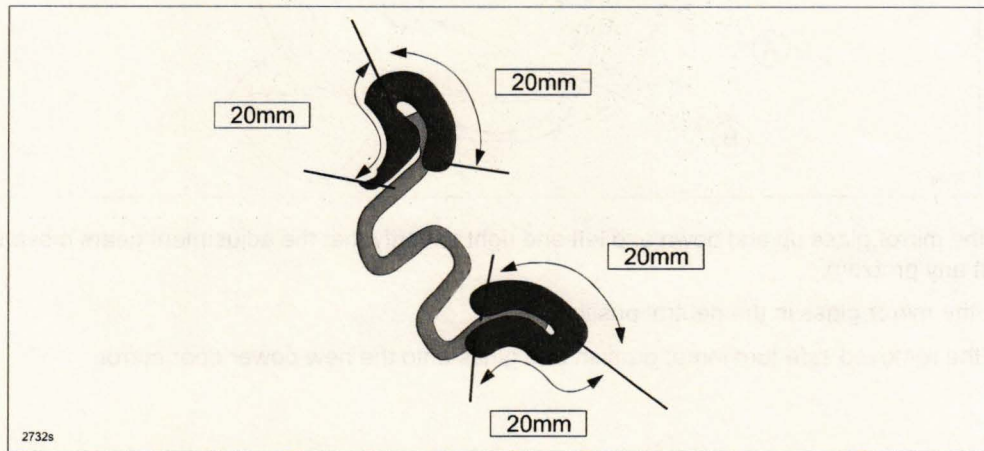

10. Install the reinforcement (A) as shown below. Secure the upper part (B) together with the power door mirror and the lower part (C) to the side impact bar-lower with the two (2) brackets.

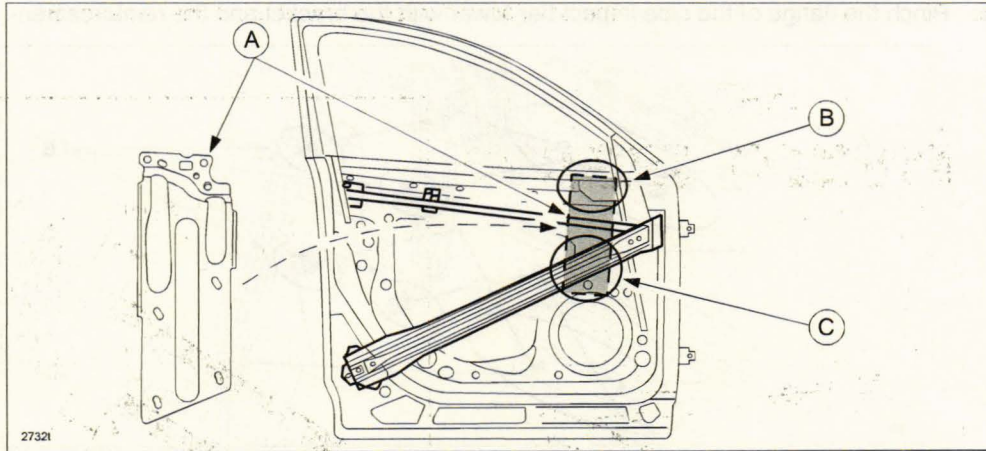

11. While holding the power door mirror, temporarily place the reinforcement with the three (3) power door mirror bolts through the holes in the reinforcement, then tighten the bolts.
Tightening Torque: 11 ft. lbf. {1.5 kgf-m, 15 Nm}

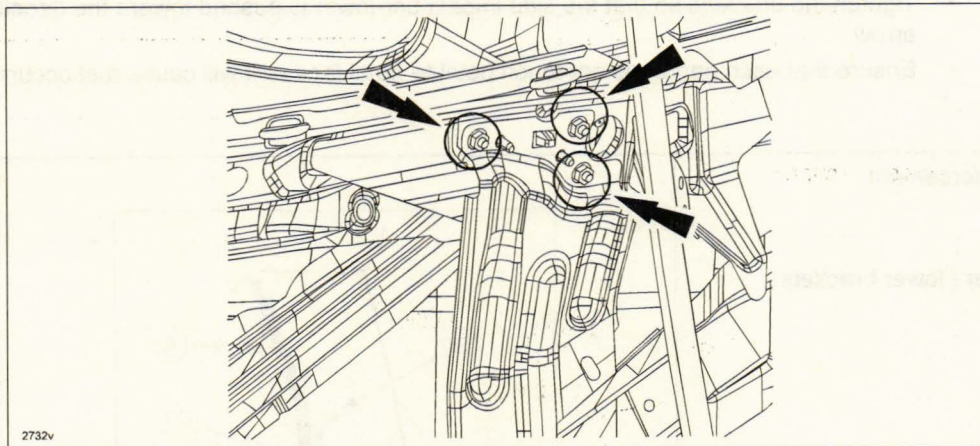

12. Place the two (2) brackets (A) (upper and lower) in the back of the reinforcement and pass the stud bolts through the holes in the reinforcement.

NOTE: Pinch the flange of the side impact bar-lower with the bracket and the reinforcement.

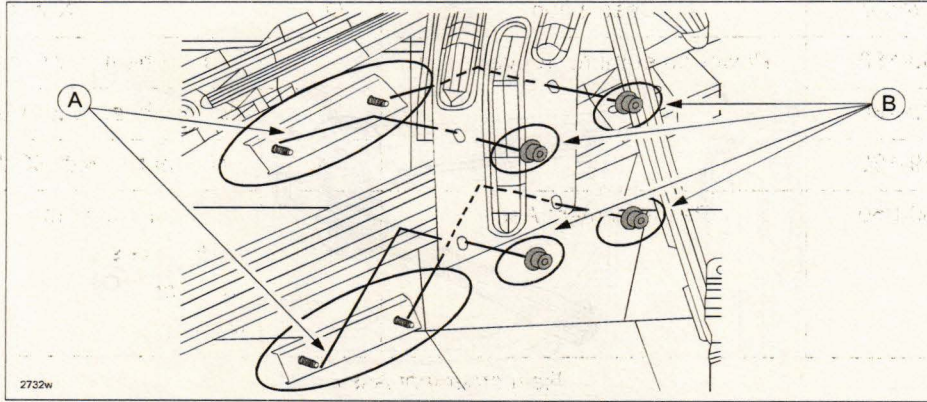

13. Tighten the four (4) nuts (B) to secure the reinforcement onto the side impact bar-lower.

Tightening Torque: 15 ft. lbf. {2.1 kgf-m, 20 Nm}

NOTE:

- Tighten the brackets so that the side impact bar-lower is pushed toward the direction of the arrow.
- Ensure that each part does not touch petal to petal face or it will cause rust occurrence.

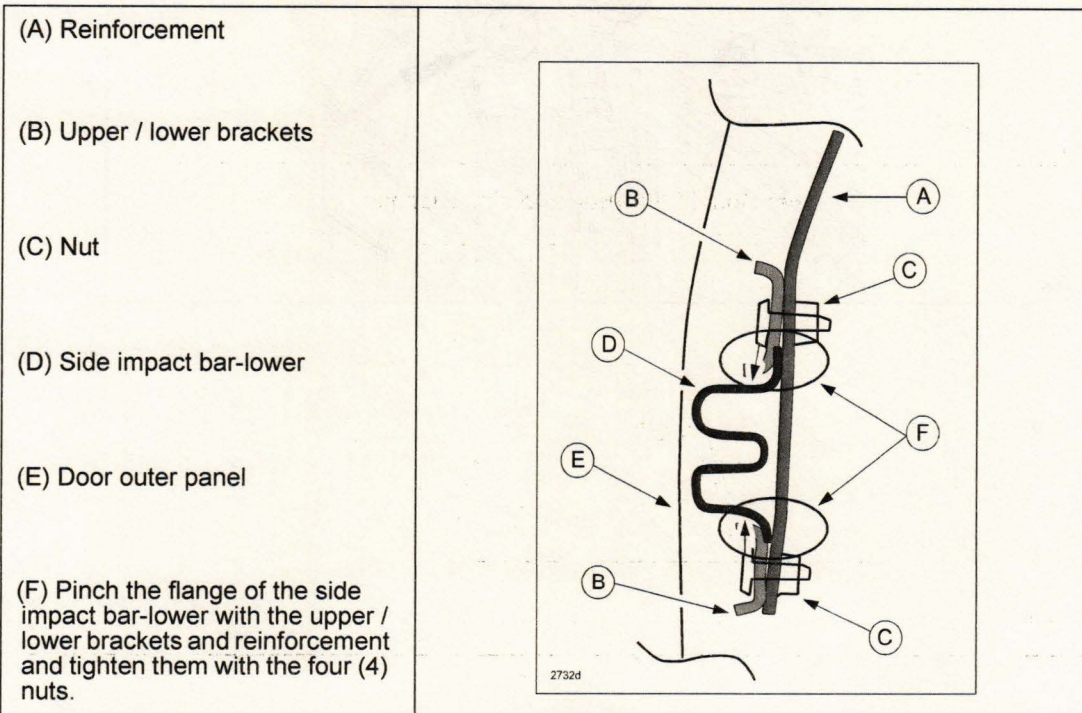

14. Install other removed parts in the reverse order of removal.

15. Verify the repair.

PART(S) INFORMATION

Part Number	Description	Qty.	Notes
KDY4-69-180	Power outer mirror (driver-side)	1	Without heater, without BSM
KDY6-69-180		1	Without heater, with BSM
KDY7-69-180		1	With heater, with BSM
KDY0-59-050	Reinforcement Assy.	1	(1) Reinforcement (2) Brackets (3) Pads (4) Nuts

Reinforcement Assy.:

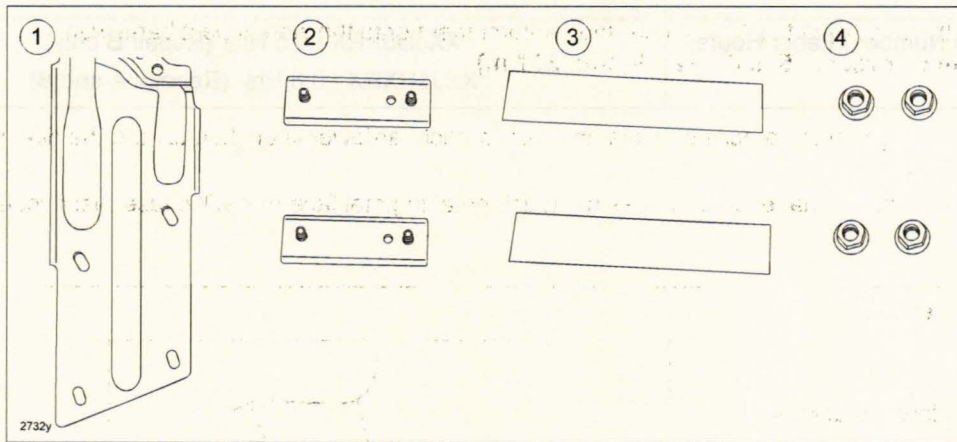

Power Door Mirror (Bolt Type Installation):

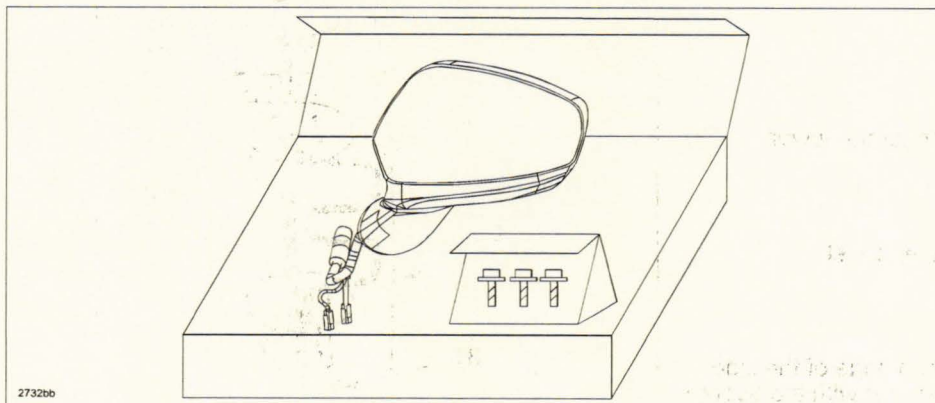

WARRANTY INFORMATION

NOTE:

- This warranty information applies only to verified customer complaints on vehicles eligible for warranty repair.
- This repair will be covered under Mazda's New Vehicle Limited Warranty term.
- Additional diagnostic time cannot be claimed for this repair.

Warranty Type	A
Symptom Code	83
Damage Code	9W
Part Number Main Cause	KDY4-69-180 or KDY6-69-180 or KDY7-69-180
Quantity	1
Operation Number / Labor Hours:	XXJD3XRX / 0.5 Hrs. (Repair B only) XXJ1HXRX / 0.8 Hrs. (Repairs A and B)