

## Tony Lawrence

---

**From:** Daniel Gonzalez  
**Sent:** Tuesday, May 20, 2014 3:45 PM  
**To:** All Dirs All Rgns - PT; All Dirs All Rgns - SR  
**Subject:** MAZDA DEALER NOTICE - SERVICE BULLETIN RELEASE

### **SERVICE BULLETIN RELEASE - 05/20/2014**

2014 INDEX: [http://www.mstore2000.com/PDF\\_Files/index05-20-14.pdf](http://www.mstore2000.com/PDF_Files/index05-20-14.pdf)

The following Service Bulletin has just been issued.

- For latest MS3 postings, click here: <https://portal.mazdausa.com/m173/service/esi/MazdaServiceShop>

- For printable PDF files from MStore, click on the link below each TSB title:

\* If the links do not automatically take you directly to the document, cut and paste the link into your internet browser address window and press enter.

#### NEW BULLETIN

09-022/14 - MULTI-MODEL - MULTIPLE ELECTRICAL MALFUNCTIONS AFTER BODY REPAIR

[http://www.mstore2000.com/PDF\\_Files/09-022-14-2921.pdf](http://www.mstore2000.com/PDF_Files/09-022-14-2921.pdf)

#### UPDATE BULLETINS

04-004/14 - MULTIPLE MODELS - BRAKE NOISE, JUDDER AND DRAGGING DIAGNOSIS AND SERVICING

[http://www.mstore2000.com/PDF\\_Files/04-004-14-2926.pdf](http://www.mstore2000.com/PDF_Files/04-004-14-2926.pdf)

09-023/14 - MULTI-MODEL - DISPLAY SHOWS INACCURATE AMBIENT TEMPERATURE

[http://www.mstore2000.com/PDF\\_Files/09-023-14-2924.pdf](http://www.mstore2000.com/PDF_Files/09-023-14-2924.pdf)

- Please distribute this information to all parts and service personnel.
- If you no longer wish to receive Mazda bulletins, please contact the IT Administrator at your dealership and ask them to remove your email address from under the EMDCS application.

© 2014 Mazda Motor of America, Inc.

**Subject:**

**MULTIPLE ELECTRICAL MALFUNCTIONS AFTER BODY REPAIR**

**Bulletin No:** 09-022/14

**Last Issued:** 05/20/2014

## APPLICABLE MODEL(S)/VINS

2013-2014 CX-5

2014 Mazda3

2014-2015 Mazda6

## DESCRIPTION

Some customers may experience an electrical malfunction after a vehicle body repair. The newly painted fender stay (B) may be causing a poor front harness (A) ground connection.

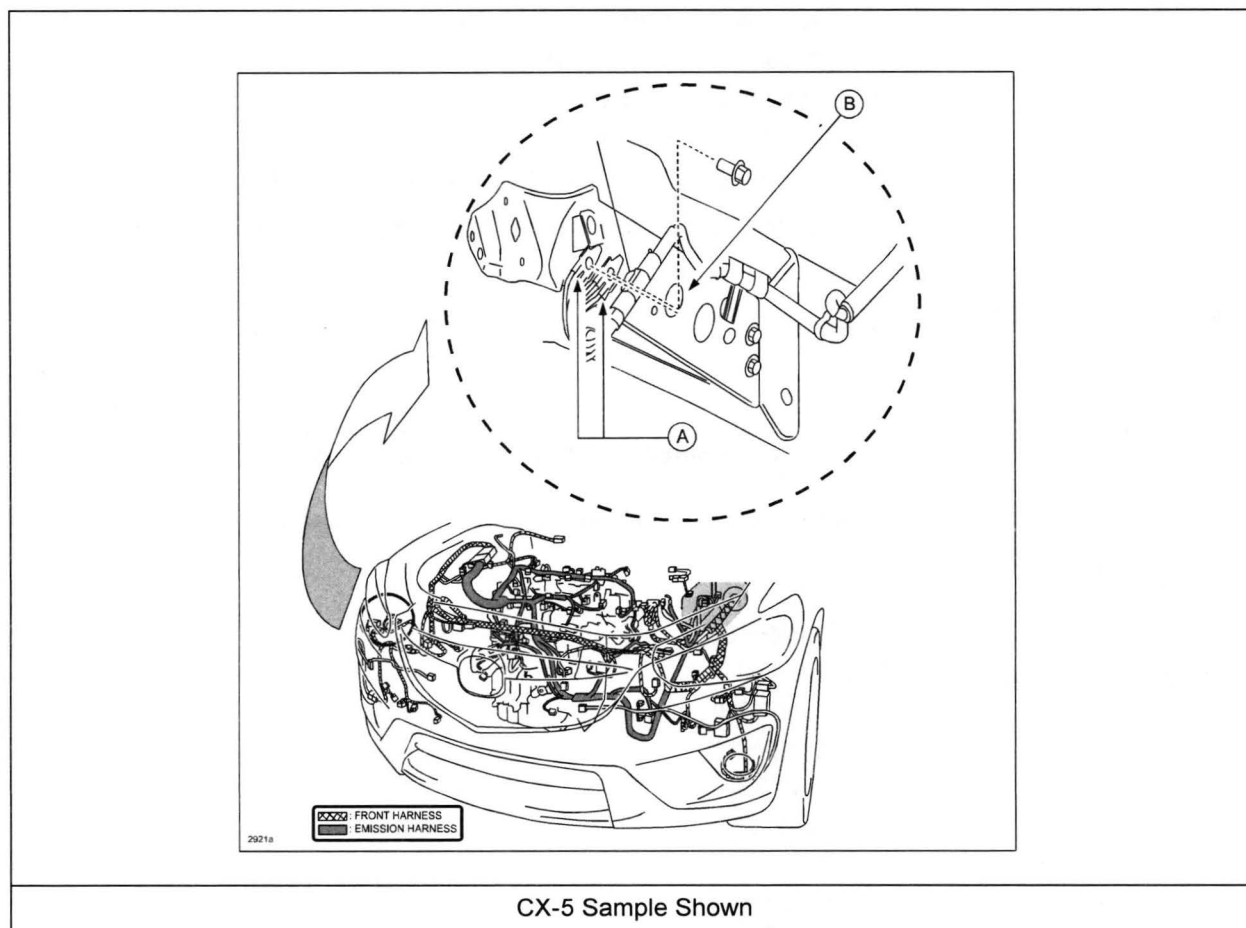

**CONSUMER NOTICE:** The information and instructions in this bulletin are intended for use by skilled technicians. Mazda technicians utilize the proper tools/equipment and take training to correctly and safely maintain Mazda vehicles. These instructions should not be performed by "do-it-yourselfers." Customers should not assume this bulletin applies to their vehicle or that their vehicle will develop the described concern. To determine if the information applies, customers should contact their nearest authorized Mazda dealership. Mazda North American Operations reserves the right to alter the specifications and contents of this bulletin without obligation or advance notice. All rights reserved. No part of this bulletin may be reproduced in any form or by any means, electronic or mechanical---including photocopying and recording and the use of any kind of information storage and retrieval system ---without permission in writing.

**SYMPTOMS**

Model	Year	Symptom
CX-5	2013-2014	Symptom 1: <ul style="list-style-type: none"> <li>• The customer states:</li> <li>- the headlight flashed ON and OFF</li> <li>- the check engine light came ON</li> <li>- the heater blower stopped</li> <li>- then the engine stalled.</li> <li>• During the dealer visit, the engine had a slow crank and no start. After charging the battery, the engine starts and the symptoms related to headlight and heater blower operation are duplicated.</li> </ul>
		Symptom 2: <ul style="list-style-type: none"> <li>• The customer states that the engine stalled while driving and did not restart.</li> <li>• Vehicle inspection finds:</li> <li>- M-MDS cannot identify the vehicle</li> <li>- the electric cooling fans are ON</li> <li>- the ignition cannot be turned OFF</li> <li>- multiple warning lights in the instrument cluster are ON</li> </ul>
Mazda3	2014	Immediately after body repair (front fender stay), the following instrument cluster warning lights are ON: <ul style="list-style-type: none"> <li>• ABS</li> <li>• Brake</li> <li>• DSC</li> <li>• TPMS</li> </ul>
Mazda6	2014-2015	<ul style="list-style-type: none"> <li>• The customer states that multiple warning lights in the instrument cluster are ON while driving.</li> <li>• Multiple DTCs are stored in multiple modules' memory.</li> <li>- C0023:62</li> <li>- C1001:92</li> <li>- U0121:00[EPS]</li> <li>- U0121:00[IC]</li> <li>- U0121:00[SCB]</li> <li>- U0121:00[PCM]</li> <li>- U0121:00[SSU]</li> <li>- U0401[BSM]</li> <li>- U0415:00</li> <li>- U2005:86[FSC]</li> </ul>

The front fender stay (B) newly painted surface at ground point (C), where attachment bolt (D) is seated, may create a poor front harness ground connection.

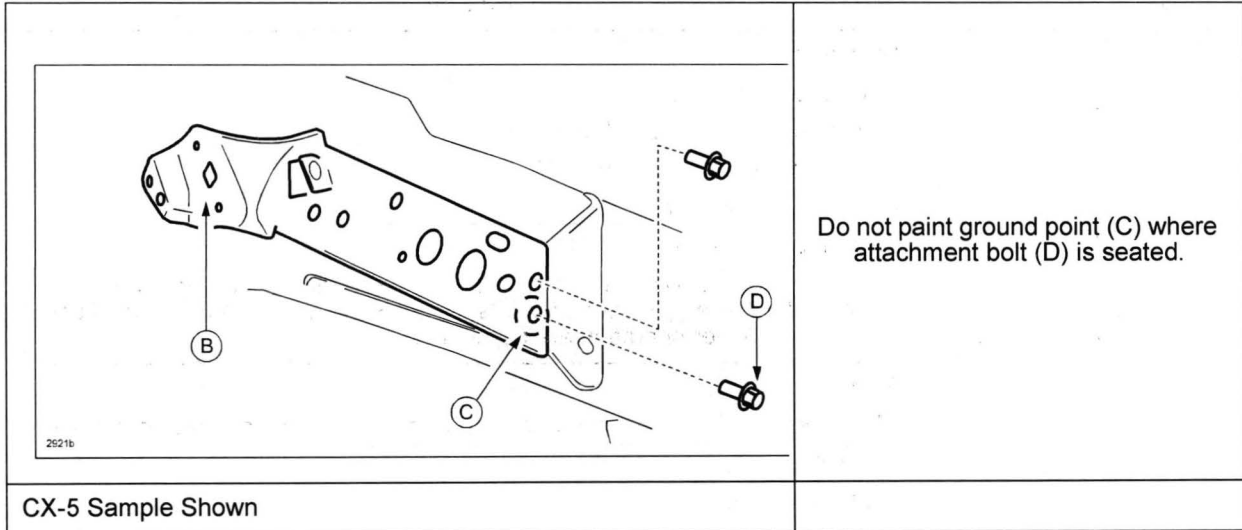

Customers concern can be resolved by sanding off paint at ground point (C) where attachment bolt (D) is seated. After installing the bolt (D), apply touch-up paint to the exposed base material area of the front fender stay.

### NEWLY INSTALLED FRONT FENDER STAY NOTE

**CAUTION:** If the bolt (D) contact area (C) is painted when the front fender stay (B) is newly replaced, it could cause a malfunction in the PCM. Before painting a newly replaced part, protect the bolt (D) contact area (C) with masking tape (E) as shown in the figure.

**NOTE:** After installing the bolt (D), apply touch-up paint to the exposed base material area of the front fender stay.

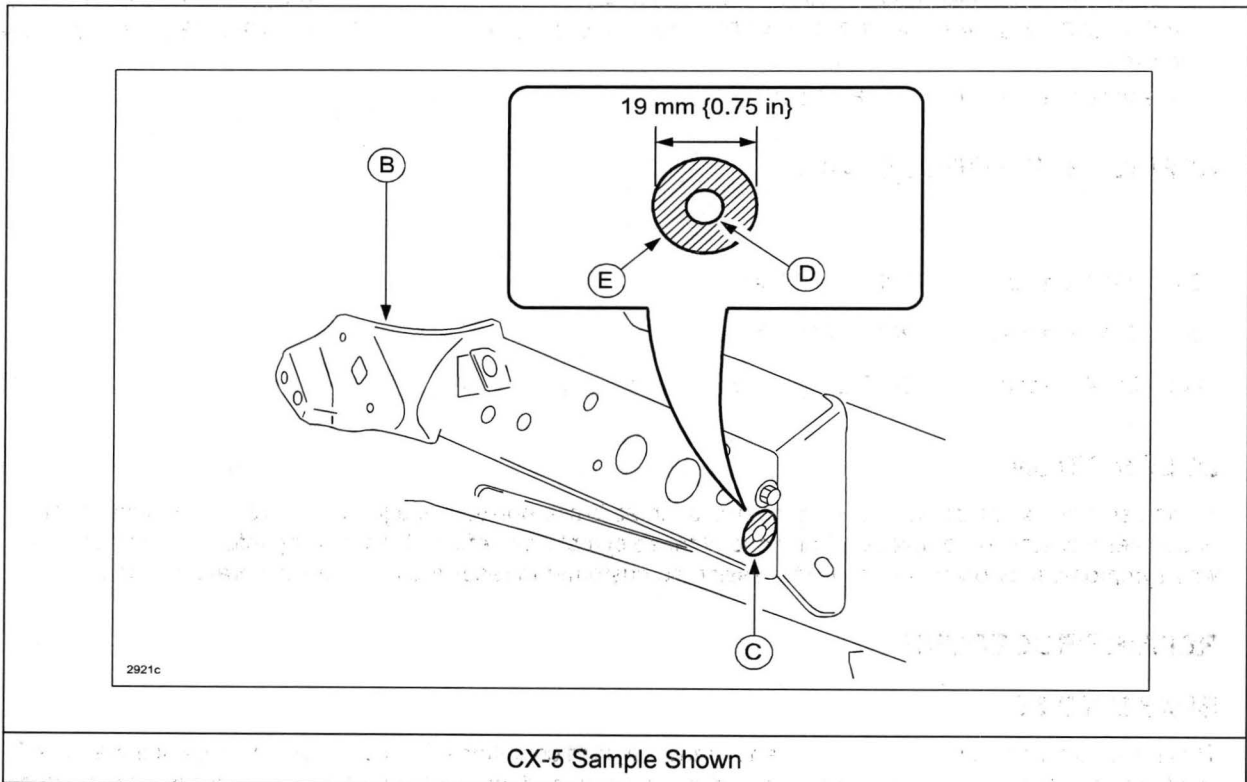

### WARRANTY COMPLIANCE NOTE

Vehicle repairs for this concern are not covered under Mazda's warranty policy.