

© 2014 Mazda Motor of America, Inc.

Subject: ACTIVE DRIVING DISPLAY VIBRATES AND/OR CANNOT BE ADJUSTED TO A VIEWABLE POSITION	Bulletin No: 09-018/14
	Last Issued: 03/12/2014

APPLICABLE MODEL(S)/VINS

2014 Mazda3 vehicles

DESCRIPTION

Some customers may complain that the Active Driving Display (A) vibrates when driving over a bump and/or cannot be adjusted to a viewable position using the commander switch.

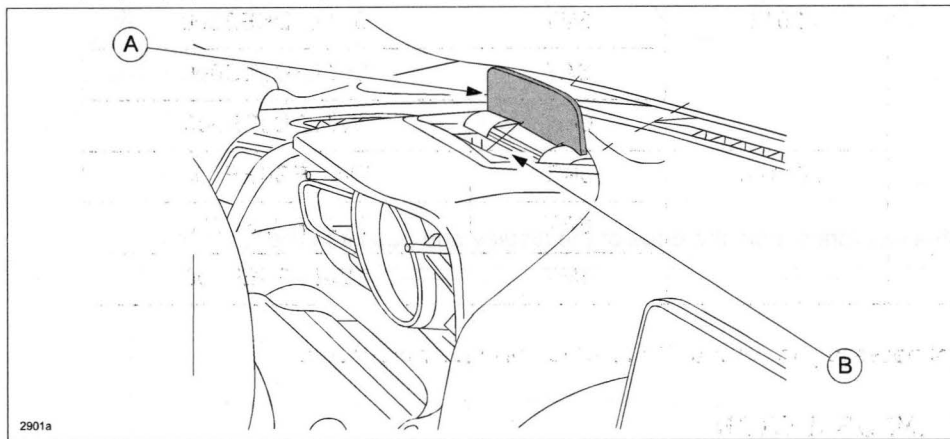

This is caused by the axis of the Active Driving Display popping out of position if the customer manually opens or closes the display, or closes the display with objects placed in the storage area (B) for the display.

Customers having this concern should have their vehicle repaired using the following repair procedure.

REPAIR PROCEDURE

1. Verify customer concern.

NOTE: Explain to the customer that the Active Driving Display should not be manually opened or closed, and to make sure that no objects are placed in the storage area for the display.

2. Start the engine to open the Active Driving Display since the work being carried out requires it to be open.
3. To insert a tool, a clearance of 1.0 - 1.5 mm at the right side is necessary.

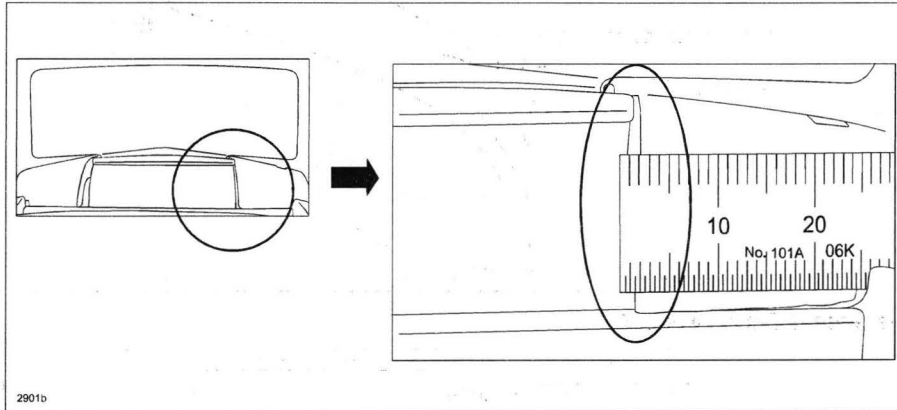

4. To establish a clearance, hold the edge of the display and push it to the left lightly.

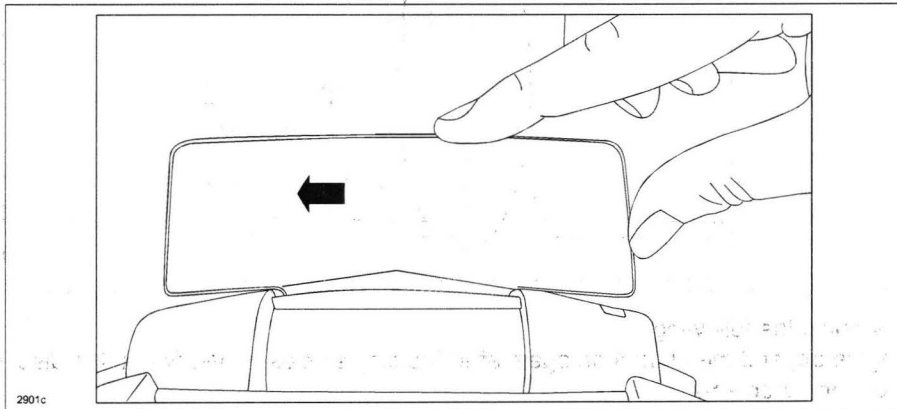

5. To avoid damage to the Active Driving Display, wrap protective tape around the tip of a tool such as a retaining clip remover.

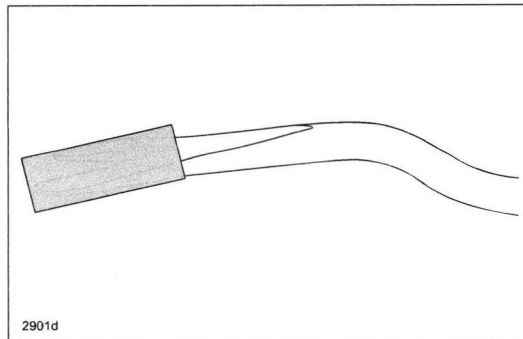

6. Insert the tool in the clearance and then push the display to the left using the tool.
- CAUTION:** Be careful not to damage the Active Driving Display with the tool.
- NOTE:** Adjust the force applied to the tool by watching the clearance.

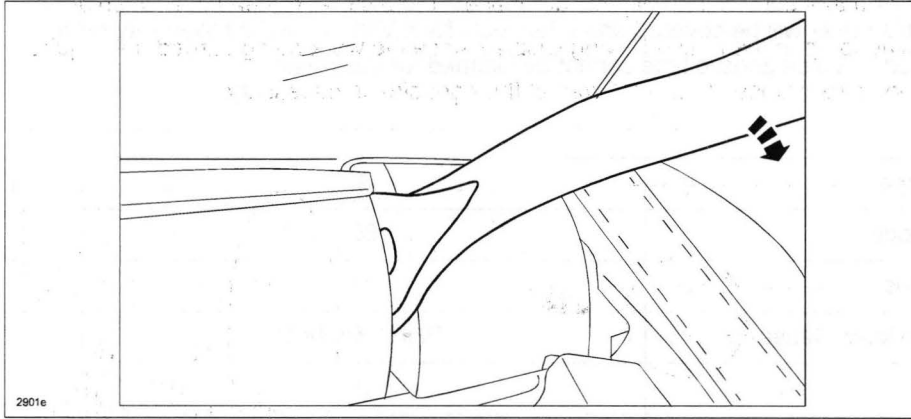

7. When the clearance is 2 mm, it is OK.

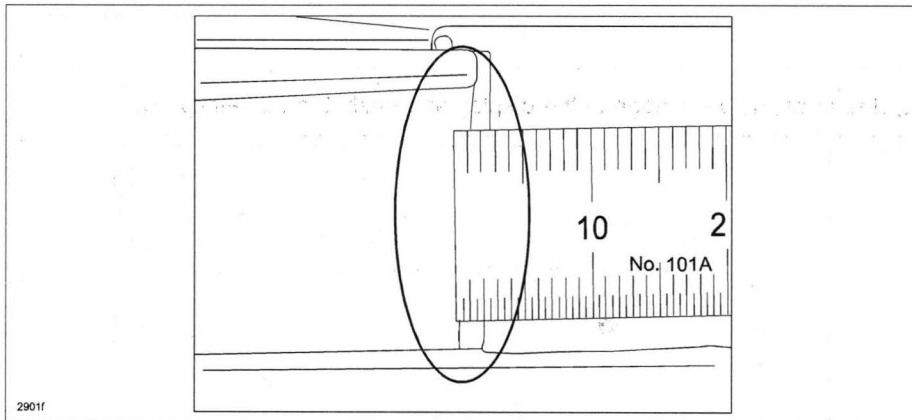

8. Verify repair by doing the following:
- Turn the engine off, and then turn it on again after the display closes. Verify that the display closes and opens without any problems.
 - Verify that you can adjust the position of the Active Driving Display using the center display and the commander switch without any problems.

Bulletin No: 09-018/14
© 2014 Mazda Motor of America, Inc.

Last Issued: 03/12/2014

WARRANTY INFORMATION

NOTE:

- This warranty information applies only to verified customer complaints on vehicles eligible for warranty repair.
- This repair will be covered under Mazda's New Vehicle Limited Warranty term.
- Additional diagnostic time cannot be claimed for this repair.

Warranty Type	A
Symptom Code	89
Damage Code	97
Part Number Main Cause	BHR1-55-44X
Quantity	0
Operation Number / Labor Hours:	XXK5DXRX / 0.2 Hrs.