

Tony Lawrence

From: Chris Ciz
Sent: Tuesday, January 28, 2014 1:42 PM
To: All Dirs All Rgns - PT; All Dirs All Rgns - SR
Subject: MAZDA DEALER NOTICE - SERVICE BULLETIN RELEASE

SERVICE BULLETIN RELEASE - 01/28/2014

2014 INDEX: http://www.mstore2000.com/PDF_Files/index01-28-14.pdf

The following Service Bulletin has just been issued.

- For latest MS3 postings, click here: <https://portal.mazdausa.com/m173/service/esi/MazdaServiceShop>
- For printable PDF files from MStore, click on the link below each TSB title:

* If the links do not automatically take you directly to the document, cut and paste the link into your internet browser address window and press enter.

NEW BULLETIN

09-009/14 – 2014 MAZDA3 - COMMANDER SWITCH DROPS INTO CENTER CONSOLE

http://www.mstore2000.com/PDF_Files/09-009-14-2871.pdf

- Please distribute this information to all parts and service personnel.
- **If you no longer wish to receive Mazda bulletins, please contact the IT Administrator at your dealership and ask them to remove your email address from under the EMDCS application.**

© 2014 Mazda Motor of America, Inc.

Subject: COMMANDER SWITCH DROPS INTO CENTER CONSOLE	Bulletin No: 09-009/14
	Last Issued: 01/28/2014

APPLICABLE MODEL(S)/VINS

2014 Mazda3 with VINs lower than JM1BM*****142131 (produced before November 6, 2013)

DESCRIPTION

Some vehicles may experience a condition where the commander switch drops down from the panel.

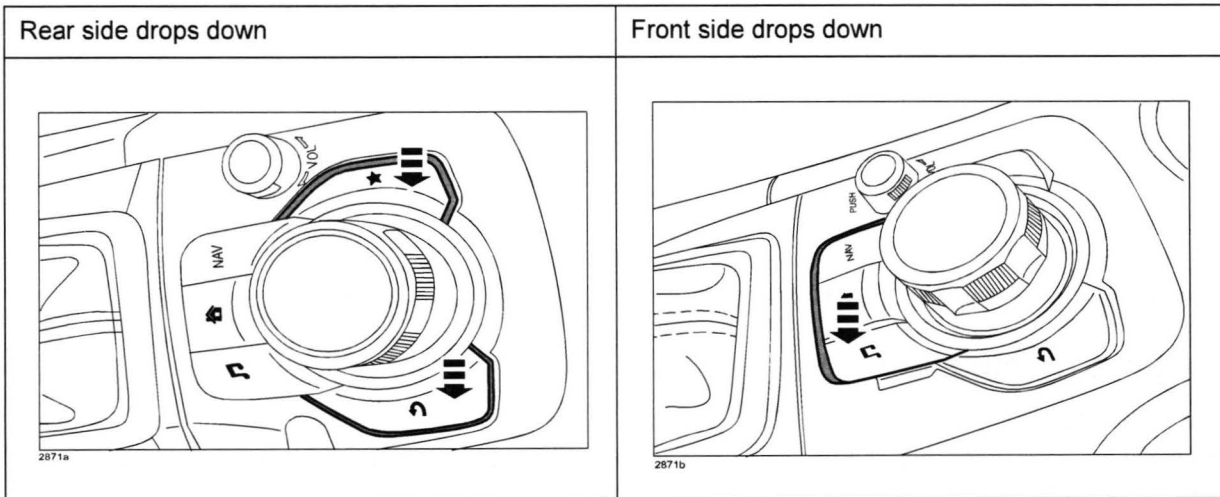

CONSUMER NOTICE: The information and instructions in this bulletin are intended for use by skilled technicians. Mazda technicians utilize the proper tools/equipment and take training to correctly and safely maintain Mazda vehicles. These instructions should not be performed by "do-it-yourselfers." Customers should not assume this bulletin applies to their vehicle or that their vehicle will develop the described concern. To determine if the information applies, customers should contact their nearest authorized Mazda dealership. Mazda North American Operations reserves the right to alter the specifications and contents of this bulletin without obligation or advance notice. All rights reserved. No part of this bulletin may be reproduced in any form or by any means, electronic or mechanical—including photocopying and recording and the use of any kind of information storage and retrieval system—without permission in writing.

Damage to the hook(s) (A) securing the commander switch (B) to the frame (C) is caused by an excessive vertical force. To correct the problem, pieces of non-woven fabric have been added to the commander switch to increase the load capacity.

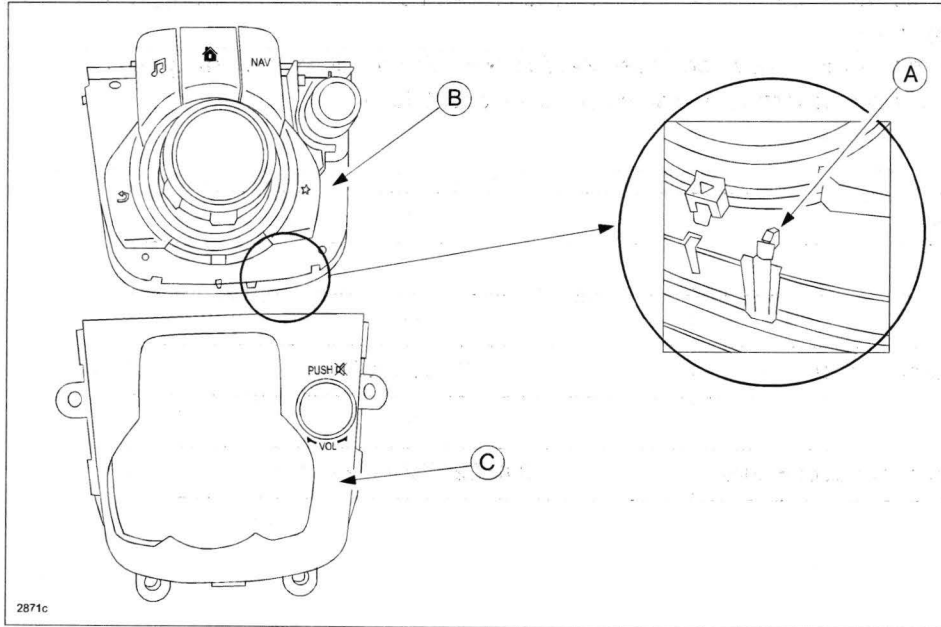

Customers having this concern should have their vehicle repaired using the following repair procedure.

REPAIR PROCEDURE

1. Verify customer concern.
2. Replace the commander switch with a modified one according to the instructions on MS3 online or the Workshop Manual (section 09-20 COMMANDER SWITCH REMOVAL/INSTALLATION).
3. Verify repair.

PART(S) INFORMATION

Part Number	Description	Qty.
BHN1-66-CM0C	Commander Switch	1

Bulletin No: 09-009/14
© 2014 Mazda Motor of America, Inc.

Last Issued: 01/28/2014

WARRANTY INFORMATION

NOTE:

- This warranty information applies only to verified customer complaints on vehicles eligible for warranty repair.
- This repair will be covered under Mazda's New Vehicle Limited Warranty term.
- Additional diagnostic time cannot be claimed for this repair.

Warranty Type	A
Symptom Code	89
Damage Code	9A
Part Number Main Cause	****-66-CM0*
Quantity	1
Operation Number / Labor Hours:	XXK22ARX / 0.2 Hrs.