

Tony Lawrence

From: Christopher Ciz
Sent: Monday, July 14, 2014 3:02 PM
To: All Dirs All Rgns - PT; All Dirs All Rgns - SR
Subject: MAZDA DEALER NOTICE - SERVICE BULLETIN RELEASE

SERVICE BULLETIN RELEASE - 07/14/2014

2014 INDEX: http://www.mstore2000.com/PDF_Files/index07-14-14.pdf

The following Service Bulletin has just been issued.

- For latest MS3 postings, click here: <https://portal.mazdausa.com/m173/service/esi/MazdaServiceShop>

- For printable PDF files from MStore, click on the link below each TSB title:

* If the links do not automatically take you directly to the document, cut and paste the link into your internet browser address window and press enter.

NEW BULLETINS

05-008/14 – MULTI-MODEL (6 SPEED SKYACTIV M/T) - HARD TO SHIFT INTO 3RD GEAR

http://www.mstore2000.com/PDF_Files/05-008-14-2920.pdf

09-032/14 – 2014 MAZDA3 (WITH MAZDA CONNECT) - CD PLAYER DISPLAY CONCERNS

http://www.mstore2000.com/PDF_Files/09-032-14-2946.pdf

UPDATED BULLETIN

06-001/14 - 2008-2011 TRIBUTE - DTC B2278 STORED IN THE POWER STEERING CONTROL MODULE

http://www.mstore2000.com/PDF_Files/06-001-14-2887b.pdf

- Please distribute this information to all parts and service personnel.
- If you no longer wish to receive Mazda bulletins, please contact the IT Administrator at your dealership and ask them to remove your email address from under the EMDCS application.



© 2014 Mazda Motor of America, Inc.

Subject: HARD TO SHIFT INTO 3RD GEAR	Bulletin No: 05-008/14
	Last Issued: 07/14/2014

APPLICABLE MODEL(S)/VINS

2012-2013 Mazda3 (SKYACTIV 6 M/T)

2014 Mazda3 (6 M/T) with VINs lower than JM1BM*****200302 (produced before April 3, 2014)

2013-2015 CX-5 (6 M/T) with VINs lower than JM3KE*****466787 (produced before April 3, 2014)

2014-2015 Mazda6 (6 M/T) with VINs lower than JM1GJ*****179179 (produced before April 3, 2014)

DESCRIPTION

Some vehicles may exhibit one of the following concerns:

- Hard to shift into 3rd gear
- Sometimes the shifter may jump out of 3rd gear over a road bump when accelerating after deceleration at 25-40 mph (40-65 km/h)

This is caused by the friction coefficient between the 3/4 clutch hub and the sleeve increasing. A surface treatment has now been added to the 3/4 clutch hub to decrease the friction coefficient.

Customers having this concern should have their vehicle repaired using the following repair procedure.

REPAIR PROCEDURE

1. Verify customer concern.
2. Remove the transaxle. Refer to MS3 online instructions or the Workshop Manual section 05-15.
3. Replace the 3/4 clutch hub with a modified one and the 3rd gear with a new one (listed in the Parts Information). Refer to the C66M-R 6-speed SKYACTIV Manual Transaxle Workshop Manual.

NOTE:

- If needed, request a "Loaner" tool on MStore to perform this procedure. Order Bearing Puller part number 4907-10-520-L only after parts to complete the repair have been received. The tool will arrive next business day if the order is placed before 2pm PST.
 - This Bearing Puller SST will be added to the MRT list and a tool will be automatically shipped to your dealer within 90 days.
4. Install the transaxle.
 5. Verify repair.

PART(S) INFORMATION

Part Number	Description	Qty.	Notes
C602-17-240A	3/4 Clutch Hub Assembly	1	All
C601-17-230B	3rd Gear	1	Except CX-5
C610-17-230A			CX-5
G054-25-421	Clip for drive shaft*	1	2012-14 Mazda3 (2.0L)
H010-25-421A			2014 Mazda3 (2.5L) 2014-15 Mazda6 2013-14 CX-5
D651-33-042A	Wheel Hub Nut*	2	All
T060-26-169A	Clip for Tie-rod End*	2	All
B455-32-099B	Bolt for Intermediate Shaft*	1	Except 2014 Mazda3
KD31-32-099			2014 Mazda3
D602-17-435B	Retaining Rig*	1	All
C601-17-435B	Retaining Rig*	1	All
C602-17-206	Ball Bearing*	1	All
C601-17-339	"O" Ring*	1	All
9956-41-800	Washer*	2	All
9956-21-600	Gasket*	1	All
9956-21-400	Washer*	2	All
0000-77-5W80-QT	Manual Transaxle Oil	3	Specification: 2.6 - 2.7 US qt

NOTE: * Replacement parts

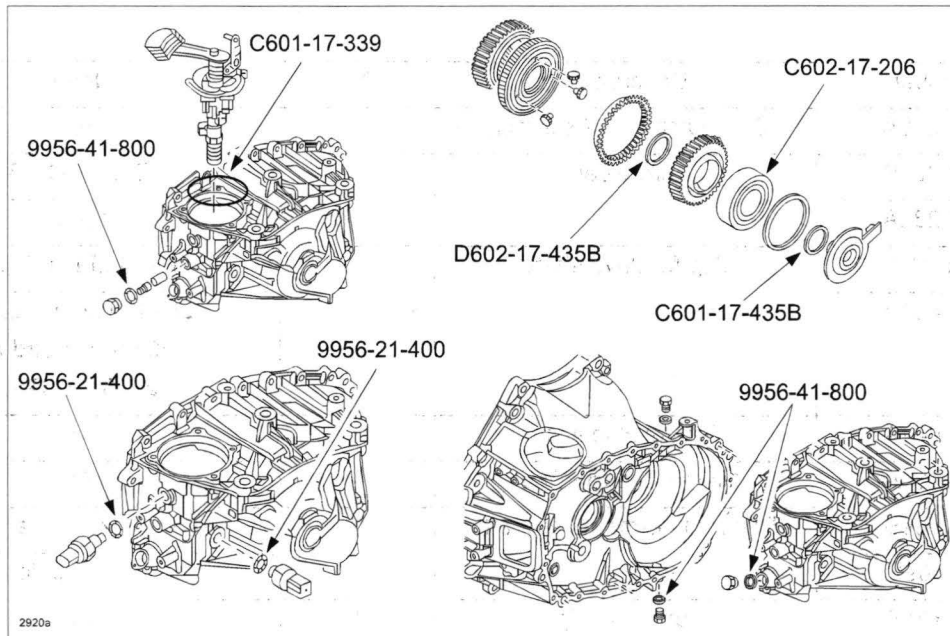

WARRANTY INFORMATION

NOTE:

- This warranty information applies only to verified customer complaints on vehicles eligible for warranty repair.
- This repair will be covered under Mazda's Powertrain Limited Warranty.
- Additional diagnostic time cannot be claimed for this repair.

Warranty Type	A
Symptom Code	24
Damage Code	9M
Part Number Main Cause	C602-17-240A
Quantity	1
Operation Number:	XXK78XRX
Labor Hours:	2012-14 Mazda3: 5.3 Hrs. 2014-15 Mazda6: 5.2 hrs. 2013-14 CX-5 (2WD): 5.5 Hrs. 2013-14 CX-5 (4WD): 7.6 hrs.