

TECHNICAL BULLETIN  
LTB00378NAS2  
09 SEP 2014



© Jaguar Land Rover North America, LLC

NOTE: The information in Technical Bulletins is intended for use by trained, professional Technicians with the knowledge, tools, and equipment required to do the job properly and safely. It informs these Technicians of conditions that may occur on some vehicles, or provides information that could assist in proper vehicle service. The procedures should not be performed by 'do-it-yourselfers'. If you are not a Retailer, do not assume that a condition described affects your vehicle. Contact an authorized Land Rover service facility to determine whether this bulletin applies to a specific vehicle.

**This reissue replaces all previous versions. Please destroy all previous versions. Only refer to the electronic version of this Technical Bulletin in TOPIx.**

Changes are highlighted in gray

**SECTION: 307-02C**

Transmission Oil Cooler Pipe Leak

**AFFECTED VEHICLE RANGE:**

**LR4 (LA)**

**Model Year:** 2010-2013

**VIN:** AA510178-DA699714

**Range Rover Sport (LS)**

**Model Year:** 2010-2013

**VIN:** AA212145-DA814822

**MARKETS:**

NAS

**CONDITION SUMMARY:**

**Situation:** The transmission oil cooler pipe(s) may exhibit a leak.

**Cause:** This may be caused by poor bracket paint finish and / or low torque on the saddle clamp nut, allowing the piped to rub through the paint.

**Action:** Should a customer express this concern, follow the Service Instruction outlined below.

**PARTS:**

LR031886	Aluminum Saddle Clamp	Quantity: 1
LR031887	Aluminum Plate	Quantity: 1
LR013811	Oil Cooler Pipe (inlet)	Quantity: 1
LR013812	Oil Cooler Pipe (outlet)	Quantity: 1
LR013730	Nut	Quantity: 1

**TOOLS:**

Refer to Workshop Manual for any required special tools.

**WARRANTY:**



**NOTE: A small quantity of transmission fluid (Shell M1375.4, [Land Rover part number TYK500050]) may be required dependent on the amount of fluid loss during replacement of the pipes. A 'ZZZ001' claim should be used to cover the cost of the fluid reflecting the amount of fluid displaced during the repair.**



**NOTE: Repair procedures are under constant review, and therefore times are subject to change;**

those quoted here must be taken as guidance only. Always refer to TOPIx to obtain the latest repair time.



**NOTE: DDW requires the use of causal part numbers. Labor only claims must show the causal part number with a quantity of zero.**

DESCRIPTION	SRO	TIME (HOURS)	CONDITION CODE	CAUSAL PART
Hoses/pipes - Feed and return - Intermediate and bracket - Renew	44.24.89.40	1.30	00	00



**NOTE: Normal Warranty policies and procedures apply.**

### **SERVICE INSTRUCTION:**

1. Raise and support the vehicle.
2. Remove the engine under tray (see TOPIx Workshop Manual, Section 501-02).
3. Remove the radiator undershield.
  - Remove the four (4) bolts.

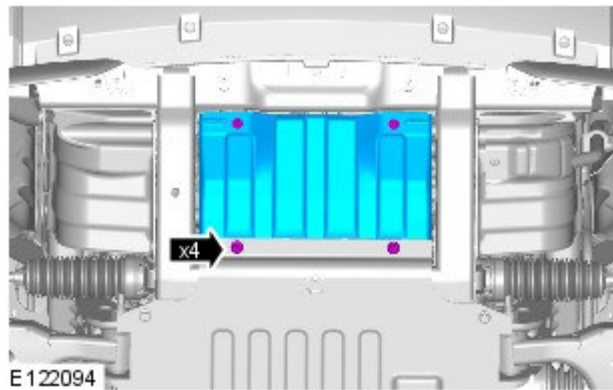

4.  **NOTE: Use a suitable container to catch any transmission fluid spillage.**

Release the two transmission fluid pipes.

- Remove and discard the securing nut and securing clamp.

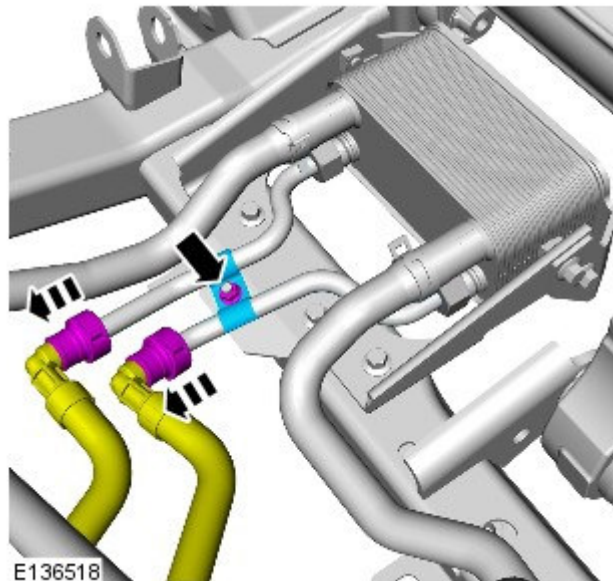

5.  **NOTE: Use a suitable container to catch any transmission fluid spillage.**

Remove and discard the two transmission fluid pipes.

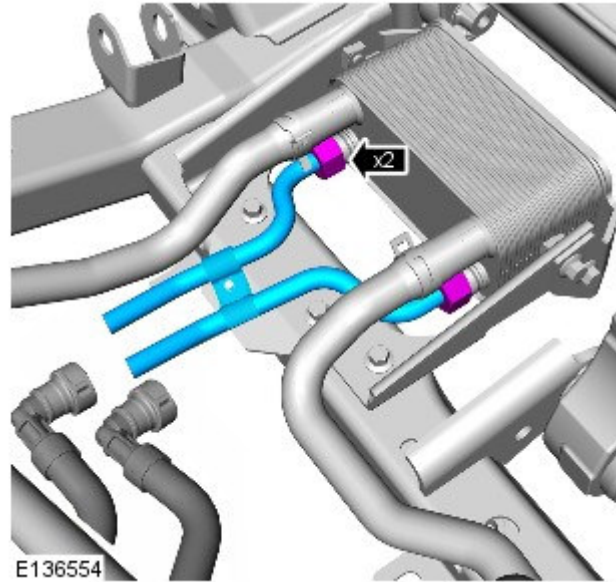

6. Install the new aluminum plate.

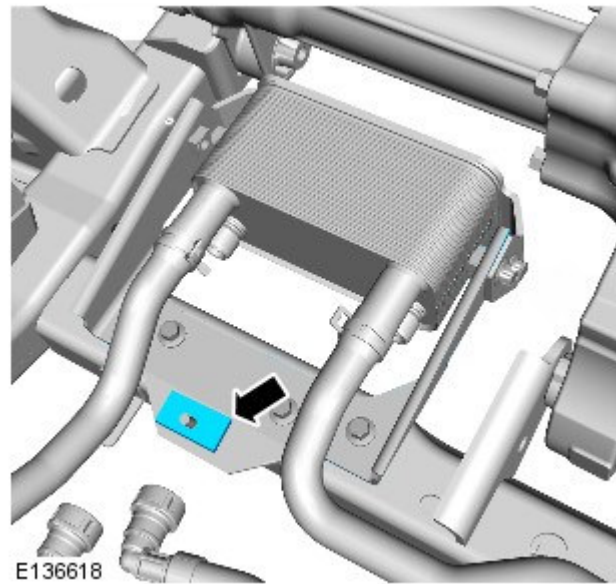

7. Install the two new transmission fluid pipes.

- Torque: 16Nm.
-

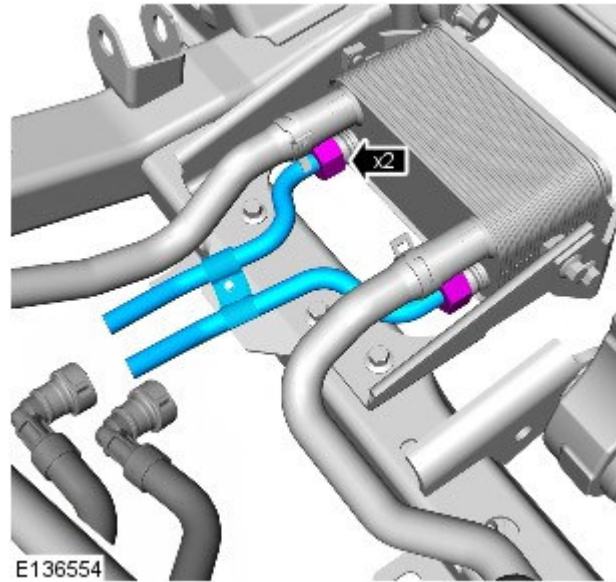

**8.** Install the two transmission fluid pipes.

- Install the new securing clamp and retaining nut.
- Torque: 10Nm.

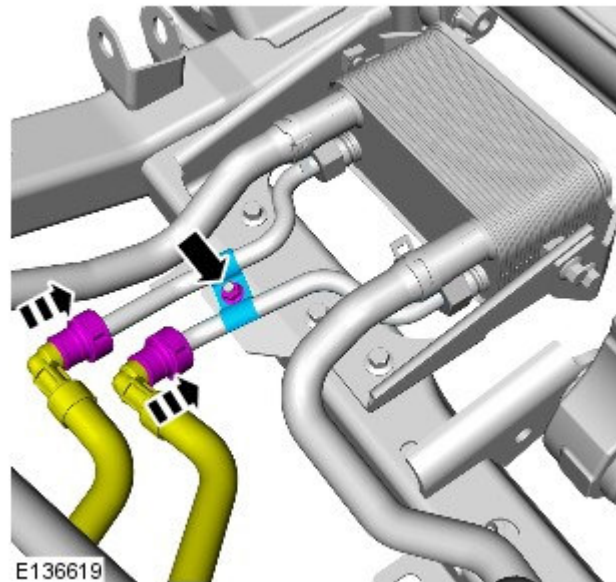

**9.** Check, and if required top up, the transmission fluid (see TOPIx Workshop Manual, section 307-01).

**10.** Install the radiator undershield.

1. Install the four (4) bolts.
- Torque: 10Nm.

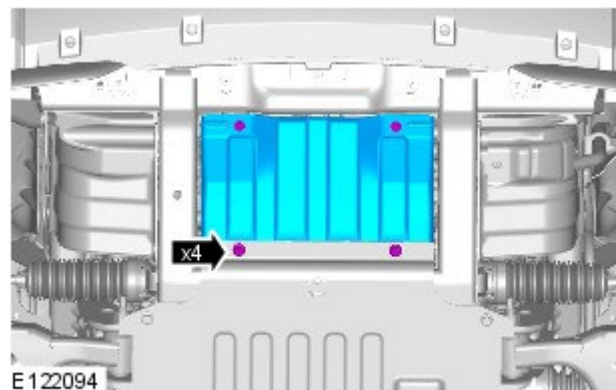

**11.** Install the engine undertray (see TOPIx Workshop Manual, Section 501-02).

**12.** Lower the vehicle.