

FLA COE
FLB COE
FLD Conventional
Business Class
FLC 112 Conventional

Century Class Conventional
Argosy COE
Cargo
Columbia

122SD and Coronado
Business Class M2
> Cascadia
108SD/114SD

Freightliner
Service Bulletin

Description of Revisions: *This bulletin replaces the version dated October 2014. The VMRS component code has been updated from 016-008-088 to 016-008-023.*

General Information

Ride height sensor arms have broken on some vehicles equipped with Meritor WABCO Electronically Controlled Air Suspension (ECAS) due to incorrect installation of the sensor, linkage, and/or Z-bracket. In these cases, the sensor was mounted aft rather than forward of the bracket, and/or the Z-bracket was attached to the axle housing outside of the correct location, which resulted in air lines or other components impeding the full travel of the arm. When the sensor, linkage, and Z-bracket are installed in the correct position, the arm should be clear of all components during travel.

Check sensor arm clearance and calibrate the ride height after replacing a broken sensor arm, and/or repositioning the sensor arm or linkage rod fasteners, and/or repositioning the Z-bracket.

Inspection of the Sensor, Linkage, and Z-Bracket Installation

NOTE: Two ride height blocks 2-5/8 inch (6.67 cm) tall and made of hardwood or aluminum are needed for setting the vehicle at proper ride height.

1. Park the vehicle on a level surface, using a light application of the brakes. Set the parking brake and chock the tires. Put the transmission in neutral. Build the secondary air pressure to at least 100 psi (690 kPa). Shut down the engine.
2. Space the tire chocks 2 inches (5 cm) ahead and behind the tire so the vehicle can roll 2 inches in either direction.
3. Release the parking brake and verify by hand that the vehicle can roll forward and aft. This should remove any load from the suspension.
4. Use the "Charge" button on the remote (up-arrow icon) to inflate the suspension air bags just enough to fit a height block between the axle stop and the u-bolt clamp group on both sides of the truck. Insert a height block on each side.
5. Lower the suspension so the frame is just resting on the blocks, then deactivate Standby Mode by holding the STOP button on the remote until the remote light turns off. Deactivating Standby Mode ensures that the system will not adjust the ride height, regardless of the position of the height sensor arm.
6. Compare the ride height sensor position of the vehicle to [Fig. 1](#). The sensor should be installed on the forward side of the sensor bracket, and the linkage rod should be on the forward side of the Z-bracket on the axle. The linkage rod should be upright, with no fore-aft tilt, as shown in [Fig. 2](#).

If the sensor or linkage rod are out of position, reposition them to match [Fig. 1](#). While the sensor is off the vehicle, inspect it for damage. If any cracking is found on the arm or body, replace the sensor.

7. Check the position of the height sensor arm and linkage rod. See [Fig. 3](#). Check that the arm is level using a level, then use a plumb bob or carpenter's square to check that the linkage rod is at a 90° (right) angle to the level sensor arm.

If the arm is level, and the linkage rod is 90° to the arm and perpendicular to the ground, no further work is necessary.

If the arm is not level, and/or the linkage rod is not 90° to the arm, check the position of the Z-bracket as follows.

- 7.1 Remove the mounting stud from the Z-bracket.

32-50

Incorrect ECAS Ride Height Sensor and Linkage Installation

Freightliner Service Bulletin

FLA COE
FLB COE
FLD Conventional
Business Class
FLC 112 Conventional

Century Class Conventional
Argosy COE
Cargo
Columbia

122SD and Coronado
Business Class M2
> Cascadia
108SD/114SD

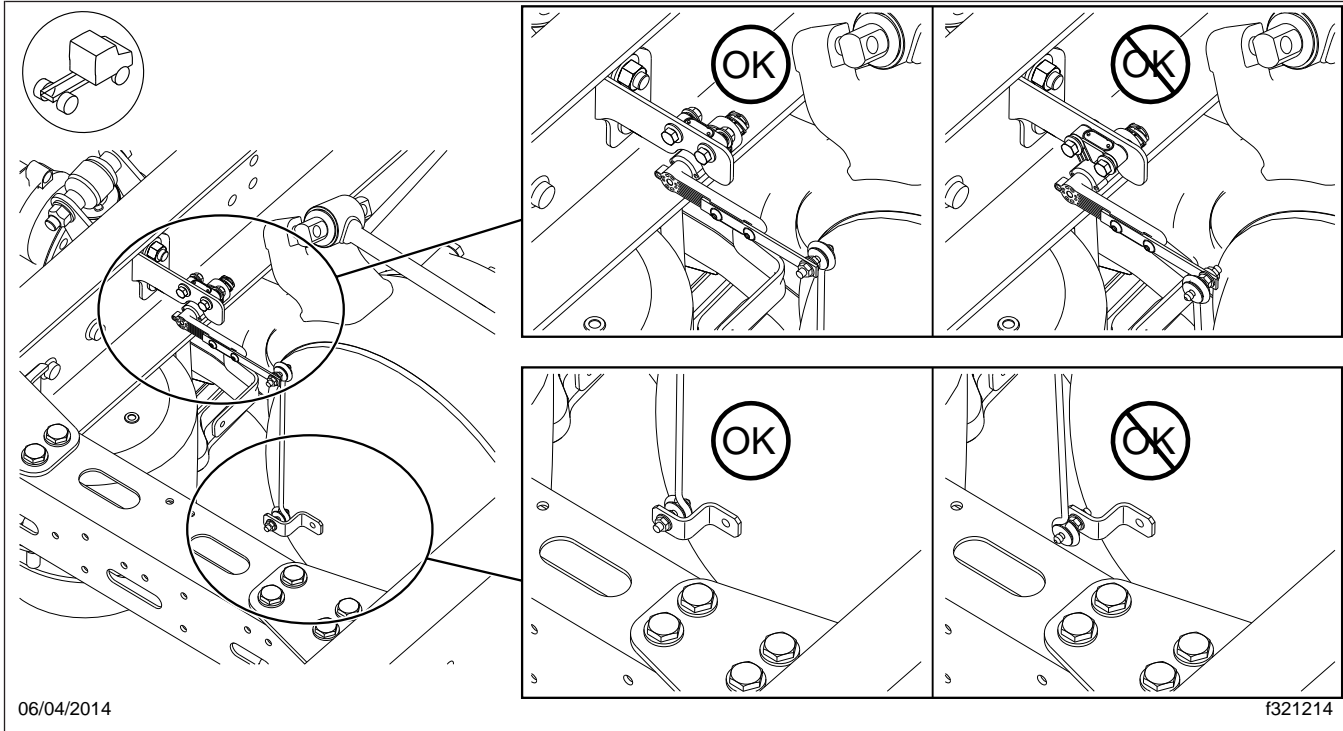

Fig. 1, Inspection of the Ride Height Sensor Installation

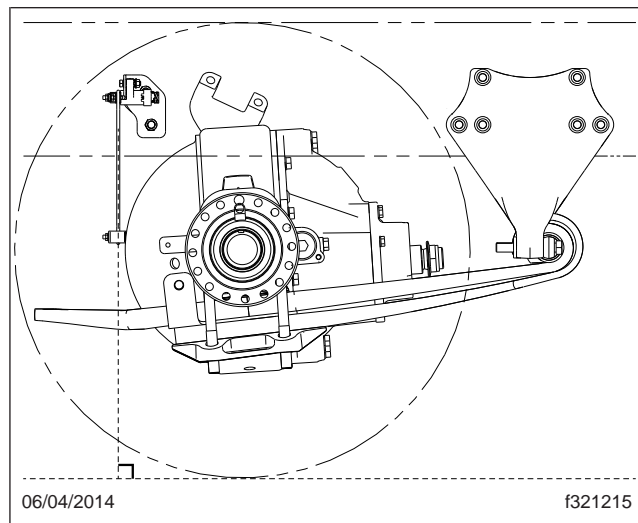

Fig. 2, The linkage rod should be perpendicular to the ground.

FLA COE
FLB COE
FLD Conventional
Business Class
FLC 112 Conventional

Century Class Conventional
Argosy COE
Cargo
Columbia

122SD and Coronado
Business Class M2
> Cascadia
108SD/114SD

**Freightliner
Service Bulletin**

- 7.2 Pin the arm to the sensor body using a 5/32-inch drill bit. If the arm isn't level when pinned, loosen the mounting fasteners and adjust the position of the sensor body on the frame bracket until the arm is level.
- 7.3 With the height sensor arm level and the linkage rod at 90°, check if the linkage end hole is within the perimeter of the Z-bracket mounting face. See **Fig. 4**.

If the end hole is within the perimeter of the Z-bracket mounting face, as shown in **Fig. 4**, the component positions are sufficient. No further work is necessary.

If the end hole is not within the perimeter of the Z-bracket mounting face, as shown in **Fig. 4**, install a new Z-bracket in the correct position. See **Positioning the Z-Bracket**.

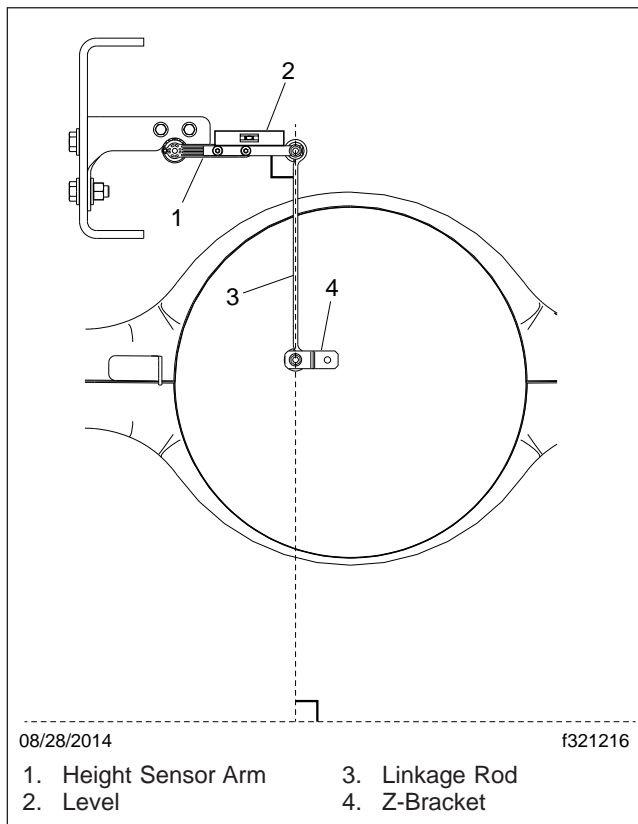

Fig. 3, Correct Position of the Arm, Linkage, and Z-Bracket

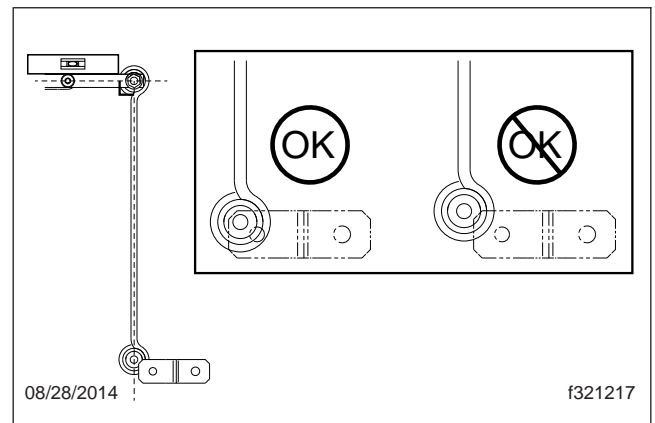

Fig. 4, Permissible Variation in Z-Bracket Position

Positioning the Z-Bracket

1. Cut off and discard the existing Z-bracket.
2. Grind off the welds, leaving the differential housing smooth.
3. With the height sensor arm pinned and level, and the linkage at 90° to the arm and perpendicular to the ground, hold the new Z-bracket up to the linkage rod end and axle housing and mark the new position on the housing.

**Freightliner
Service Bulletin**

 FLA COE
 FLB COE
 FLD Conventional
 Business Class
 FLC 112 Conventional

 Century Class Conventional
 Argosy COE
 Cargo
 Columbia

 122SD and Coronado
 Business Class M2
 > Cascadia
 108SD/114SD

4. Remove the paint where the new Z-bracket will be located.
5. With the height sensor arm pinned and level, and the linkage at 90° to the arm and perpendicular to the ground, hold the new Z-bracket up to the linkage rod end and axle housing and mark the new position on the housing.
6. Find a good spot for the welder ground clamp on the housing near the work area. Remove paint as needed for good contact.
7. Weld the new Z-bracket in place. Weld the center hole first, then the top and side edge.
8. Check the position of the height sensor arm, linkage, and Z-bracket to make sure the angles are correct with the new Z-bracket position.
9. Once the Z-bracket and housing are cool, prime and paint the new Z-bracket and anywhere paint was removed. See **Group 98** of the *Cascadia Workshop Manual*.
10. Reconnect the linkage, making sure it matches the installation in **Fig. 1**. Turn the key on and use the ECAS remote control to lift the suspension enough to remove the height blocks.

Sensor Arm Clearance Check and Ride Height Calibration

Check sensor arm clearance and calibrate the ride height after replacing a broken sensor arm, and/or repositioning the sensor arm or linkage rod fasteners, and/or repositioning the Z-bracket.

1. Park the vehicle on a level surface, using a light application of the brakes. Set the parking brake and chock the tires. Put the transmission in neutral. Build the secondary air pressure to at least 100 psi (690 kPa). Shut down the engine.
2. Space the tire chocks 2 inches (5 cm) ahead and behind the tire so the vehicle can roll 2 inches in either direction.
3. Release the parking brake and verify by hand that the vehicle can roll forward and aft. This should remove any load from the suspension.
4. Check for sensor arm clearance at both the maximum upper and lower travel using Toolbox 11:

NOTE: Toolbox contains a number of popup warning notes for user safety. These work instructions expect the user to heed the warning note and click "Ok" in each instance.

- 4.1 Make sure Toolbox 11.2 is installed on the computer that will be connecting to the vehicle. Toolbox versions older than 11.0 will not work with ECAS.
- 4.2 Connect the Nexiq connector to the vehicle and the computer.
- 4.3 Open Meritor WABCO Toolbox 11.2. Click the ECAS CAN 2 (Truck and Bus) icon.
- 4.4 Click the "Calibration" button to go to the Calibration window.
- 4.5 Activate both rear drive and tag axles by clicking both "Middle" buttons. The buttons will show blue when active.

IMPORTANT: Watch the height sensor arm very carefully when checking for clearance. Stop immediately if the arm comes within 1/2 inch of any line or component while raising and lowering the suspension.

- 4.6 Use the "Charge" button (up arrow icon) to inflate the suspension air bags until the suspension reaches maximum height. Watch the arm for 1/2-inch clearance of all components. The shock absorbers create the hard upper limit for suspension height.

FLA COE
FLB COE
FLD Conventional
Business Class
FLC 112 Conventional

Century Class Conventional
Argosy COE
Cargo
Columbia

122SD and Coronado
Business Class M2
> Cascadia
108SD/114SD

**Freightliner
Service Bulletin**

- 4.7 Use the "Vent" button (down arrow icon) to lower the suspension until the axle stops rest on the axle clamp group. Watch the arm for 1/2-inch clearance of all components.
- 4.8 If any lines are closer than 1/2 inch to the arm at the ends of its travel, remove the zip ties and adjust the lines to give the arm clearance.

If a component—such as the 5th wheel—is closer than 1/2 inch to the arm at the ends of its travel, evaluate the position of the Z-bracket on the axle housing.

NOTE: Two ride height blocks 2-5/8 inch (6.67 cm) tall and made of hardwood or aluminum are needed for the calibration.

NOTE: The air tank may need to be charged again before calibrating the ride height.

- 5. Calibrate the ride height. See the ECAS calibration procedure in **Group 32** of the *Cascadia Workshop Manual*. During calibration, check to make sure that the lower and upper ride height boundaries still leave the sensor arm 3/4 inch or more clear of any lines and components.

Parts

Use the parts listed in [Table 1](#) for the procedure **Positioning the Z-Bracket**.

Parts		
Part Number	Description	Quantity
11-19440-000	Z-Bracket	1

Table 1, Parts

Warranty

This procedure is warrantable only if the described condition exists and the repair is performed within the applicable base or extended coverage warranty period. If a failure is not found, this procedure is considered preventive and warranty does not apply.

Normal warranty applies. See [Table 2](#) for OWL VMRS codes and labor allowance information. Enter this service bulletin number in the *Service Bulletin #* field.

OWL VMRS Codes and Labor Allowance					
Primary Failed Part	Component Code	Cause Code	SRT Code	Description	Time: Hours
TDA S441 050 100 0	016-008-023	33	622-5006A	ECAS, Height Sensor & Linkage, Remount & Cal SB 32-50	0.8
TDA S441 050 100 0	016-008-023	33	622-5006B	ECAS, Sensor & Linkage, Remount/Weld, SB 32-50	1.4

Table 2, OWL VMRS Codes and Labor Allowance