



Service Bulletin

SB-10057079-2072



SERVICE UPDATE

SUBJECT: Service Update for Inventory and Customer Vehicles
Rear Door Inside Handle Release Cable Misrouted
Expires with Base Warranty

MODELS: 2014-2015 Cadillac CTS Sedan (VIN A)

This service update includes vehicles in dealer inventory and customer vehicles that return to the dealership for any reason. This bulletin will expire at the end of the involved vehicle's New Vehicle Limited Warranty period.

PURPOSE

This bulletin provides a service procedure to inspect the glass travel on both rear doors on **certain** 2014-2015 model year Cadillac CTS sedan (VIN A) vehicles. These vehicles may have been built with a rear door inside handle release cable that is misrouted. A misrouted release cable could restrict the glass travel. An unlocked door with this condition will unlatch and open when an attempt is made to fully lower the window. Once unlatched, the door will not shut until the window is raised and there is an attempt to operate the inside release handle. A locked door with this condition will jam in a locked state when an attempt is made to fully lower the window. Once jammed, the door – even if unlocked - will not open from the outside until the window is raised and there is an attempt to operate the inside release handle.

If a cable is misrouted, dealers are to replace the latch, inside release cable, and the inside release handle, and route the cable correctly.

This service procedure should be completed as soon as possible on involved vehicles currently in dealer inventory and customer vehicles that return to the dealer for any type of service during the New Vehicle Limited Warranty coverage period.

VEHICLES INVOLVED

All involved vehicles are identified by VIN in the Global Warranty Management System – Investigate Vehicle History Application. Dealership technicians should always check this site to confirm vehicle involvement prior to beginning any required inspections and/or repairs. It is important to routinely use this tool to verify eligibility because not all similar vehicles may be involved regardless of description or option content.

Additionally, a list of involved vehicles currently in dealer inventory is available on the “Service Update Bulletin Information” link under the “Service” tab in GM GlobalConnect (US) or attached to the GlobalConnect message (Canada) used to release this bulletin. Customer vehicles that return for service, for any reason, and are still covered under the vehicle's base warranty should also be checked for vehicle eligibility.

PART INFORMATION

Parts required to complete this service update are to be obtained from General Motors Customer Care and Aftersales (GMCC&A). Please refer to your “involved vehicles listing” before ordering parts. Normal orders should be placed on a DRO = Daily Replenishment Order. In an emergency situation, parts should be ordered on a CSO = Customer Special Order.

Part Number	Description	Quantity/Vehicle
23446629	CABLE ASM-RR S/D I/S HDL	1 or 2 (if req'd)
13592257	LATCH ASM-RR S/D (L) (w/UTT)	1 (if req'd)
13592276	LATCH ASM-RR S/D (R) (w/UTT)	1 (if req'd)
13592259	LATCH ASM-RR S/D (L) (w/o UTT)	1 (if req'd)
13592258	LATCH ASM-RR S/D (R) (w/o UTT)	1 (if req'd)
23168710	HANDLE ASM-RR S/D I/S (L)	1 (if req'd)
23168711	HANDLE ASM-RR S/D I/S (R)	1 (if req'd)

SERVICE PROCEDURE

Inspection Procedure

Fully open both left and right rear windows and inspect for full travel of the door glass down into the door.



3997956

- If the windows lower fully into both doors, no further action is necessary.



3997957

- If window travel is restricted on either rear side door, continue ahead to the *Repair Procedure*.

Repair Procedure

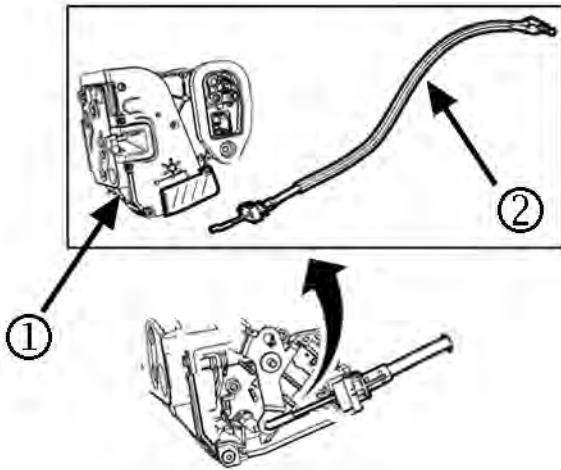

3997960

1. Remove the rear side door latch (1) and the rear side door inside handle cable (2) from the affected door. Refer to *Rear Side Door Inside Handle Cable Replacement* in SI.

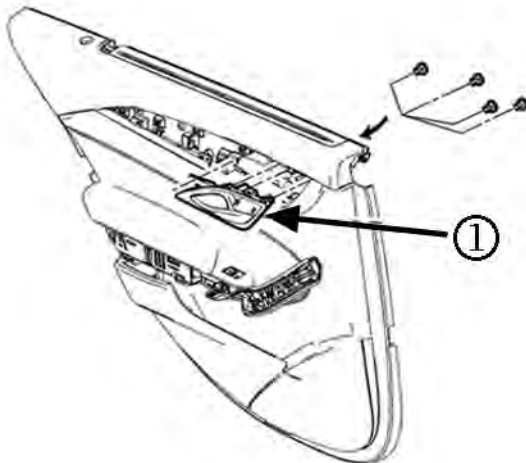

3997965

2. Remove the rear side door inside handle (1) from the door trim assembly. Refer to *Rear Side Door Inside Handle Replacement* in SI.

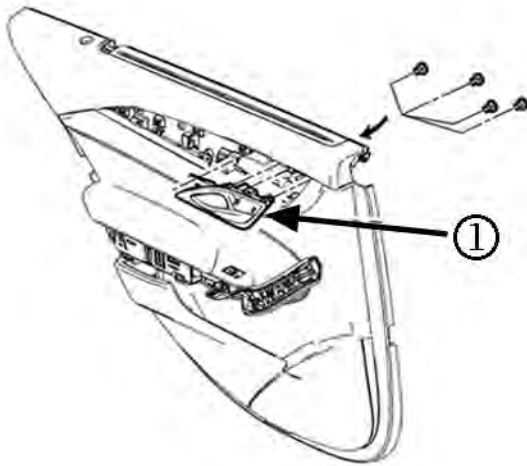

3997965

3. Install a new rear side door inside handle (1) to the door trim assembly. Refer to *Rear Side Door Inside Handle Replacement* in SI.

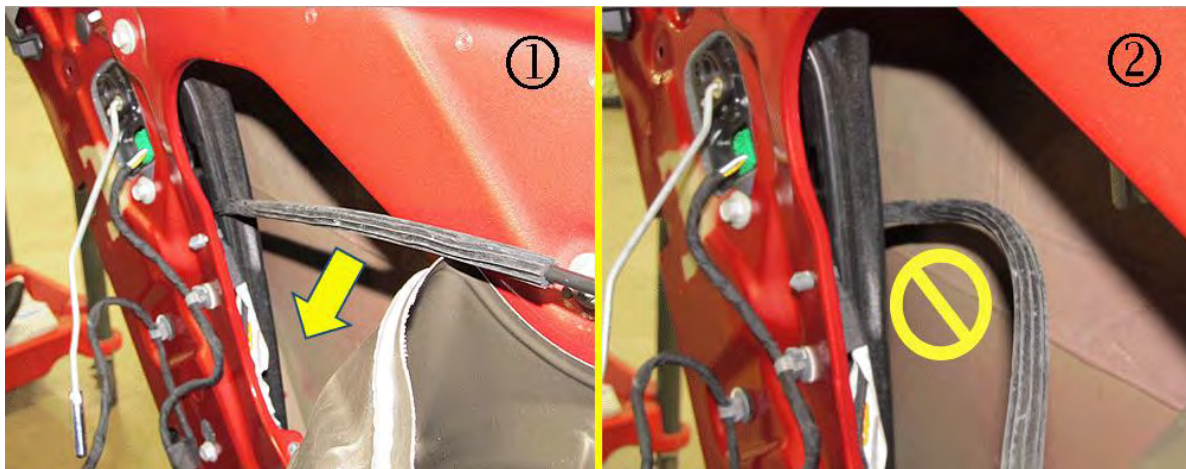

3997967

Note: When installing the new rear side door inside handle cable, ensure proper routing of the cable within the door. As shown in the graphic above, the cable **MUST** be routed on the inboard side (1) of the vertical glass channel, **NOT** the outboard side (2).

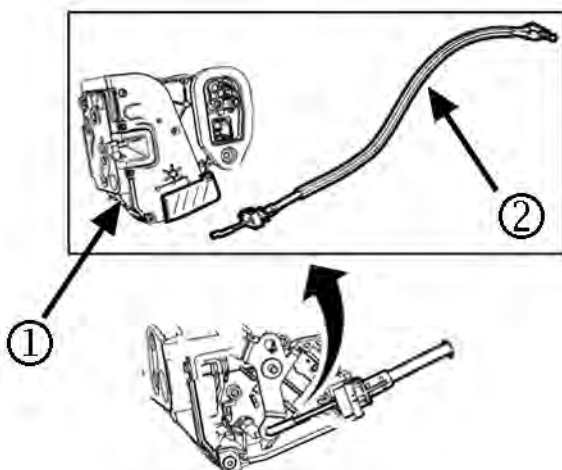

3997960

4. Install a new rear side door latch (1) and new rear side door inside handle cable (2) to the affected door. Refer to *Rear Side Door Inside Handle Cable Replacement* in SI.
5. Prior to installing the door trim panel, verify proper operation of the door glass lowering fully into the door.

6. If necessary, repeat Steps 1-5 on the opposite side rear door.

WARRANTY TRANSACTION INFORMATION

Submit a transaction using the table below. All transactions should be submitted as a ZFAT transaction type, unless noted otherwise.

Labor Code	Description	Labor Time
9101113	Inspect Rear Window Travel – No Further Action Req'd	0.2
9101114	Replace One Latch, Inside Handle, & Cable (inc. inspect)	0.9
	Add: Replace Second Latch, Inside Handle, & Cable	0.7

DEALER PROGRAM RESPONSIBILITY

Whenever a vehicle subject to this service update enters your vehicle inventory, or is in your facility for service in the future, and the vehicle is still covered under the New Vehicle Limited Warranty, you must take the steps necessary to be sure the service update correction has been made before selling or releasing the vehicle.

