

FLA COE
FLB COE
FLD Conventional
Business Class
FLC 112 Conventional

Century Class Conventional
Argosy COE
Cargo
Columbia

> 122SD and Coronado
> Business Class M2
> Cascadia
> 108SD/114SD

Freightliner
Service Bulletin

General Information

Some powernet distribution box (PNDB) modules may experience poor fuse retention on the keep-alive circuits. This could cause intermittent operation of any devices supplied by these circuits. On units equipped with remote sense, it could result in the alternator overcharging, even on alternators capable of self-regulating.

NOTE: A self-regulating alternator may substitute the voltage reading from its primary battery positive, in the event that the remote sense line is a constant open circuit.

If the fuses are not seating properly on the keep-alive circuits, or are falling out, use the instructions in this bulletin to replace the PNDB.

PNDB Replacement

NOTE: The powernet distribution box (PNDB) is located on the cab frontwall, above the main ground junction block. See [Fig. 1](#).

1. Disconnect all batteries. If the vehicle is equipped with an auxiliary battery bank, disconnect these batteries as well.
2. Open the hood.

IMPORTANT: Inspect the keep-alive and cab load disconnect switch (CLDS) connectors and make sure that the plugs are in unused connector cavities. Install plugs to seal the connector if any are missing.

3. Disconnect the cab load disconnect switch (CLDS) connector, if equipped.
4. Disconnect the keep-alive circuit connector from the PNDB.
 - 4.1 Using a flat-head screwdriver, push the red locking tab up.
 - 4.2 Press and release the tab, then remove the connector. See [Fig. 2](#).
5. Disconnect the power cables from the PNDB.
6. Remove the PNDB.
7. Position the new PNDB on the frontwall, and attach the two mounting nuts.
8. Attach the keep-alive circuit connector and the CLDS connector.
9. Connect the power cables. Torque the nut 15 lbf·ft (20 N·m).
10. Connect all batteries, including the auxiliary batteries, if equipped.
11. Close the hood.

Warranty

This procedure is warrantable only if the described condition exists and the repair is performed within the applicable base or extended coverage warranty period. If a failure is not found, this procedure is considered preventive and warranty does not apply.

Normal warranty applies. See [Table 1](#) for OWL VMRS codes and labor allowance information. Enter this service bulletin number in the *Service Bulletin #* field.

54-287

Powernet Distribution Box Fuse Retention on the Keep-Alive Circuit

Freightliner Service Bulletin

FLA COE
 FLB COE
 FLD Conventional
 Business Class
 FLC 112 Conventional

Century Class Conventional
 Argosy COE
 Cargo
 Columbia

> 122SD and Coronado
 > Business Class M2
 > Cascadia
 > 108SD/114SD

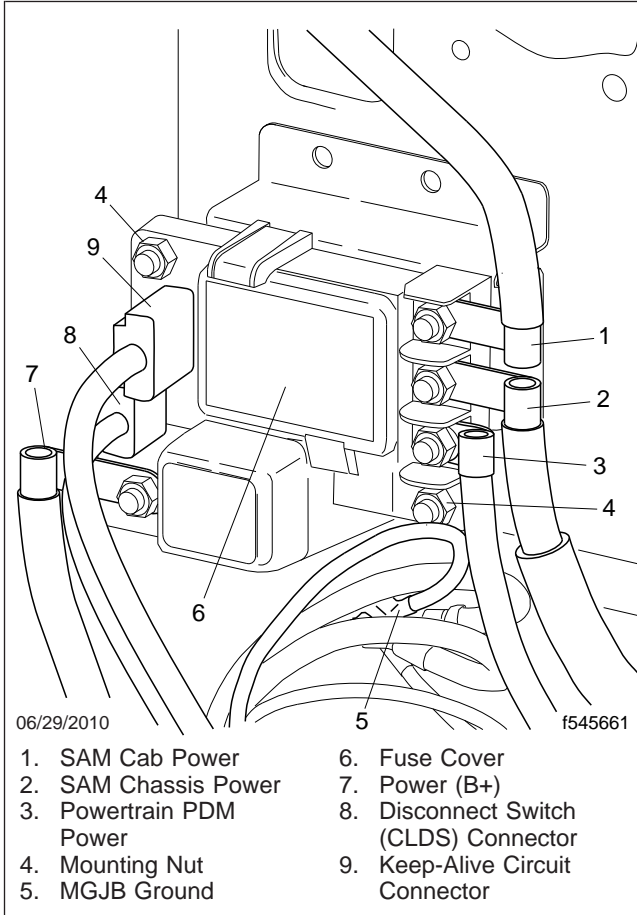

Fig. 1, Powernet Distribution Box

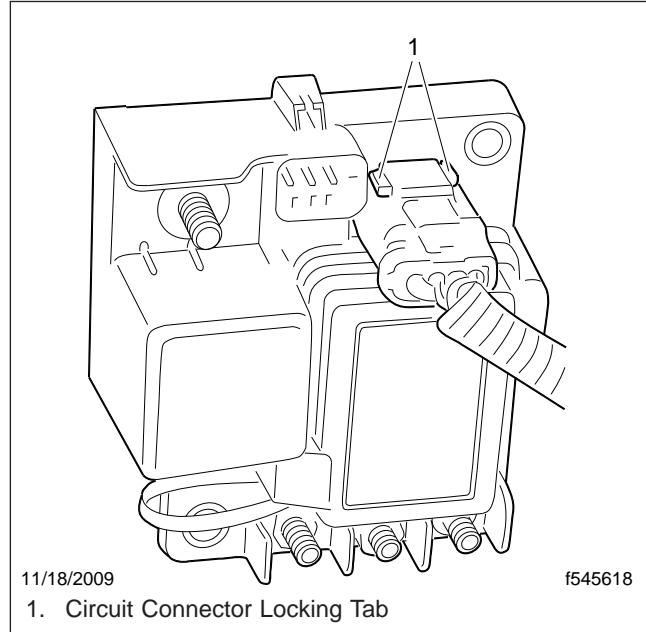

Fig. 2, Removing the Circuit Connector

OWL VMRS Codes and Labor Allowance					
Primary Failed Part	Component Code	Cause Code	SRT Code	Description	Time: Hours
Powernet Distribution Box	034-004-181	23	285-5025A	Powernet Distribution Box, Inspection, R/R	0.5

Table 1, OWL VMRS Codes and Labor Allowance