



September 27, 2014

ATB 51877-00169 REV1 (1409)

Front Brake Caliper Bracket Contacts Rotor Causing Grinding, Rubbing, or Screeching Noise

Supersedes 14-038, dated September 23, 2014, to revise the information highlighted in yellow.

AFFECTED VEHICLES

Year	Model	Trim	VIN Range
2014	Odyssey	ALL	5FNRL5...EB098185 thru 5FNRL5...EB110523
2015	Odyssey	ALL	5FNRL5...FB009095 thru 5FNRL5...FB014769

REVISION SUMMARY

- The Operation Number was changed under WARRANTY CLAIM INFORMATION.

SYMPTOM

The front brakes grind, rub or screeches

POSSIBLE CAUSES

An improperly machined front brake caliper bracket may come in contact with the front brake disc(s).

CORRECTIVE ACTION

Replace the left, the right, or both front brake caliper brackets and refinish the disc(s). If necessary, replace the brake disc(s).

PARTS INFORMATION

Part Name	Part Number	Quantity
Left-Front Brake Caliper Assembly	45019-TK8-A01	1
Right-Front Brake Caliper Assembly	45018-TK8-A01	1

CUSTOMER INFORMATION: The information in this bulletin is intended for use only by skilled technicians who have the proper tools, equipment, and training to correctly and safely maintain your vehicle. These procedures should not be attempted by "do-it-yourselfers," and you should not assume this bulletin applies to your vehicle, or that your vehicle has the condition described. To determine whether this information applies, contact an authorized Honda automobile dealer.

WARRANTY CLAIM INFORMATION

The normal warranty applies.

Operation Number	Description	Flat Rate Time	Failed Part Number
4101E6	Replace one front brake caliper bracket	0.5	45019-TK8-A01
A	Add to if replacing both front caliper brackets	0.3	
B	Add to resurface one front brake disc (Do not use with Combo Code "C")	0.4	
C	Add to resurface both front brake discs (Do not use with Combo Code "B")	0.8	
D	Add to if replacing one front brake disc (Do not use with Combo Code "E")	0.2	
E	Add to if replacing both front brake discs (Do not use Combo Code "D")	0.4	

Defect Code: 07701

Symptom Code: 04201

Skill Level: Repair Technician

REPAIR PROCEDURE

1. Raise and support the vehicle.
2. Remove the front wheels.
3. Remove the brake hose mounting bolt.

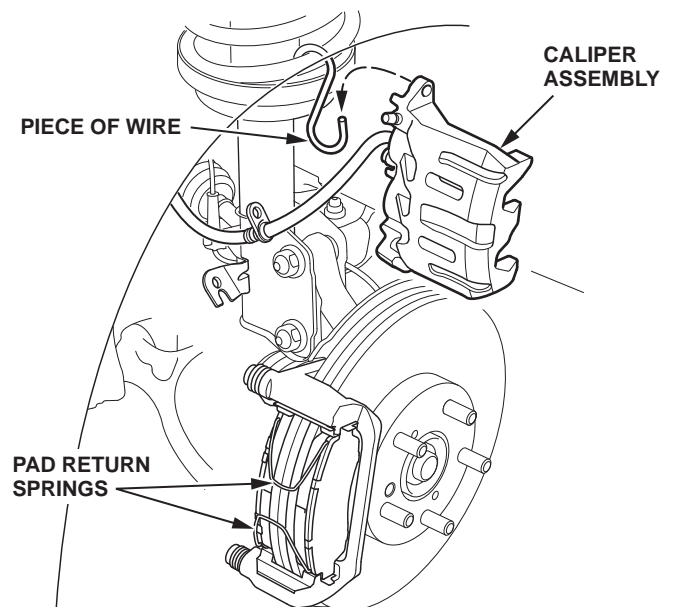
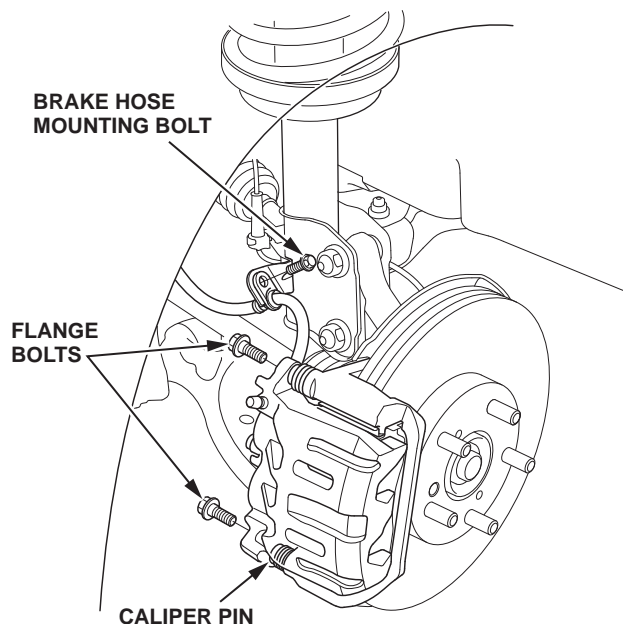

4. While holding the caliper pins with a wrench, remove the flange bolts. Being careful not to damage the pin boots, remove the caliper and hang it up out of the way. To prevent damage to the caliper or brake hose, use a short piece of wire to hang the caliper from the undercarriage. Do not twist the brake hose excessively. Check the hose for damage and deterioration.

5. Hold the brake pads and remove the pad springs.

NOTE: The pad return springs are installed on the pads to prevent brake drag. Be careful when removing the caliper body or the spring could pop out of position.

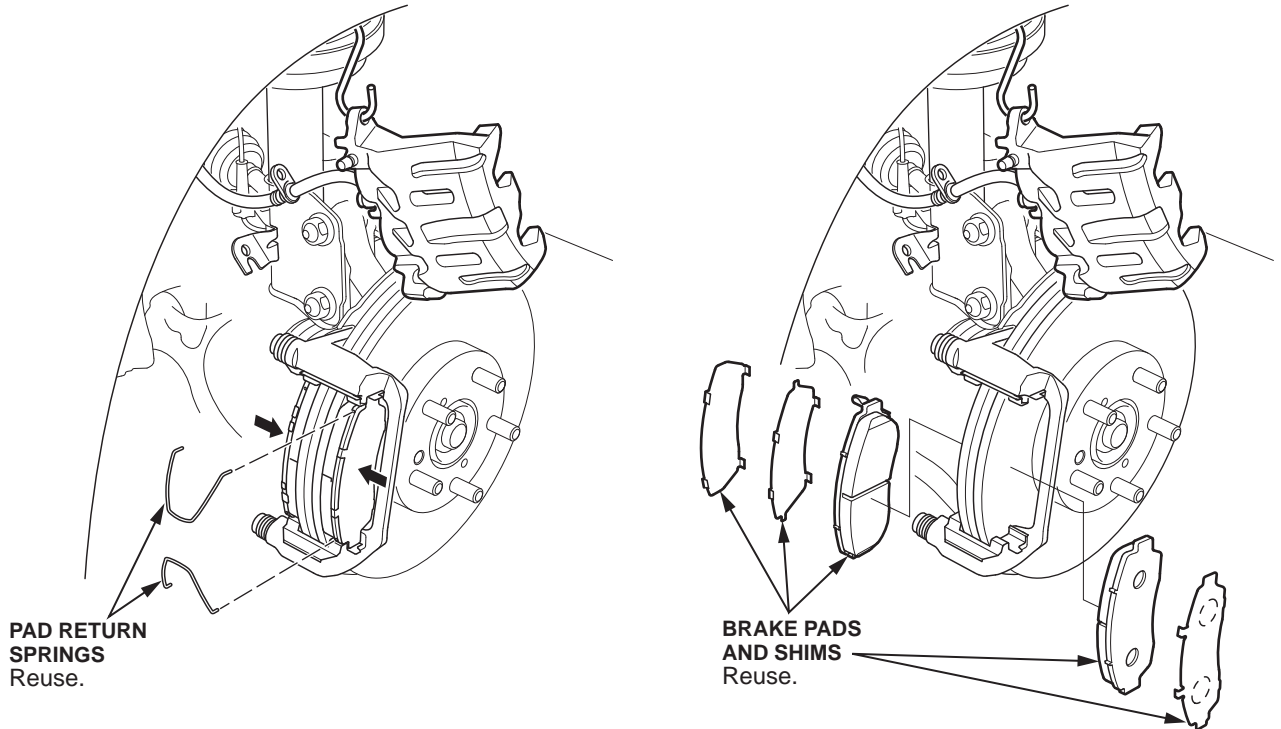

6. Remove the brake pads

7. Remove the brake caliper bracket mounting bolts, then remove the caliper bracket from the knuckle.

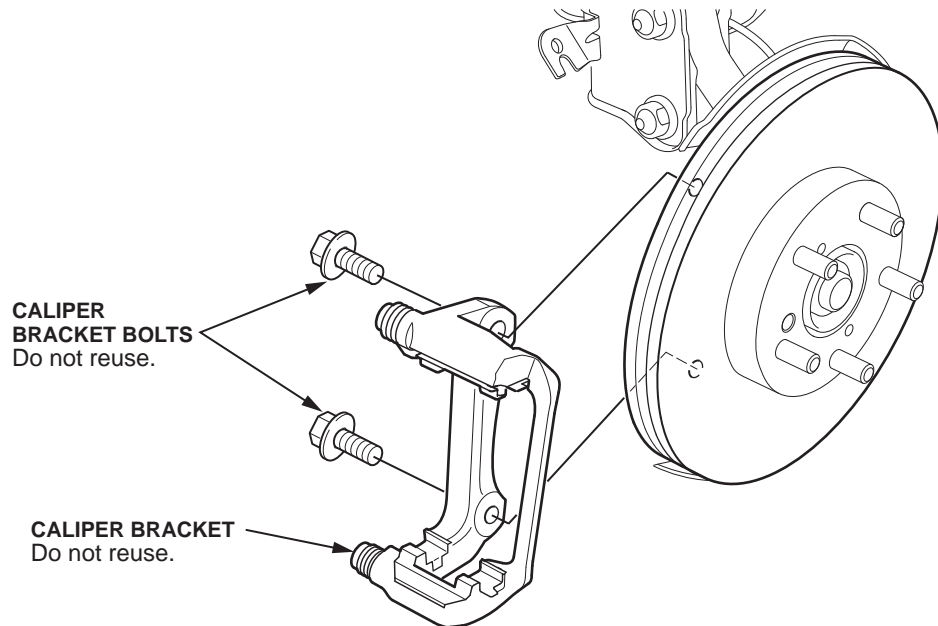

8. Inspect both surfaces of the brake disc and the insides of both brake retainers for any damage. Repeat for the opposite side.
- If there is damage go to step 09.
 - If there is no damage go to step 11.

Inspect both disc surfaces.

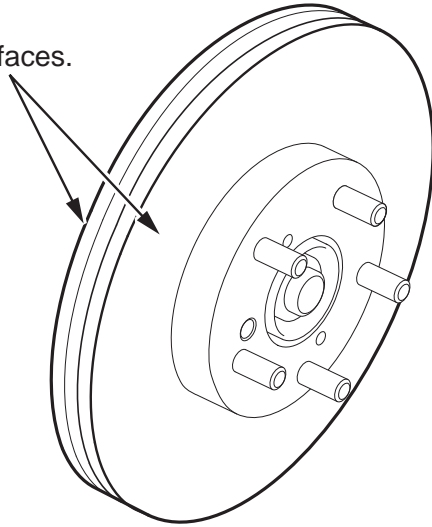

Inspect the inside surface of the brake retainers.

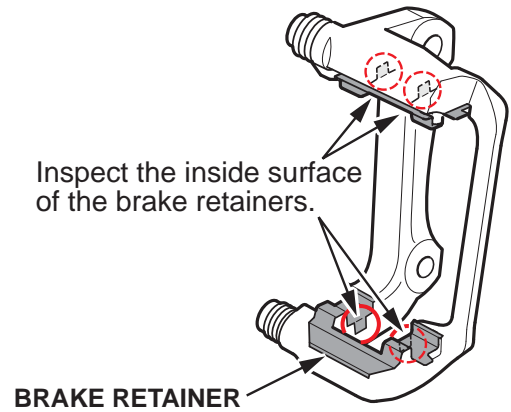

9. Refinish the damaged brake disc (or the side which has a damaged retainer) with a Honda-approved commercially available on-car brake lathe to remove any damage. Refer to S/B 00-088.
10. After refinishing the disc, use a micrometer to measure the brake disc thickness about 10 mm (0.39 in) in from the outer edge of the brake disc. Maximum refinishing limit: 26.0 mm (1.024 in)
- If the disc is within specification, go to step # 11
 - If the disc is not within specification, replace the brake disc then got to step #11

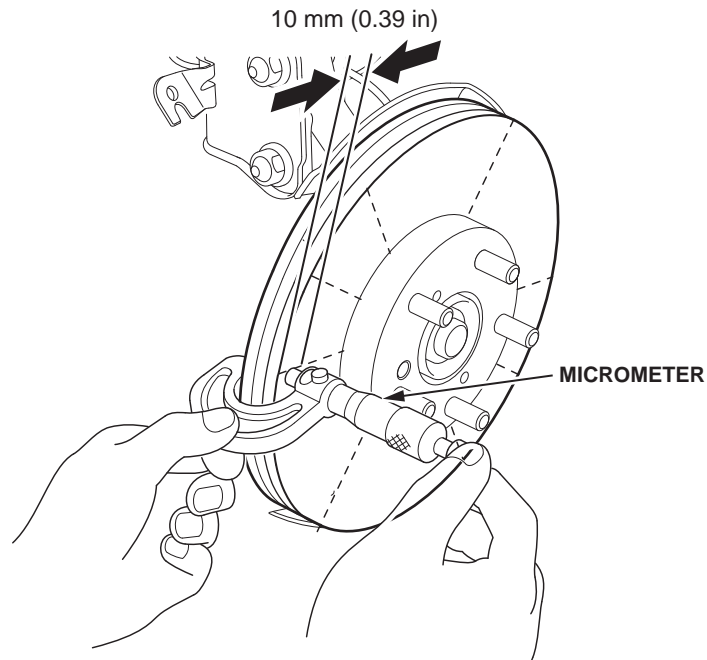

11. Remove the new caliper bracket from the caliper. The new caliper will not be used.

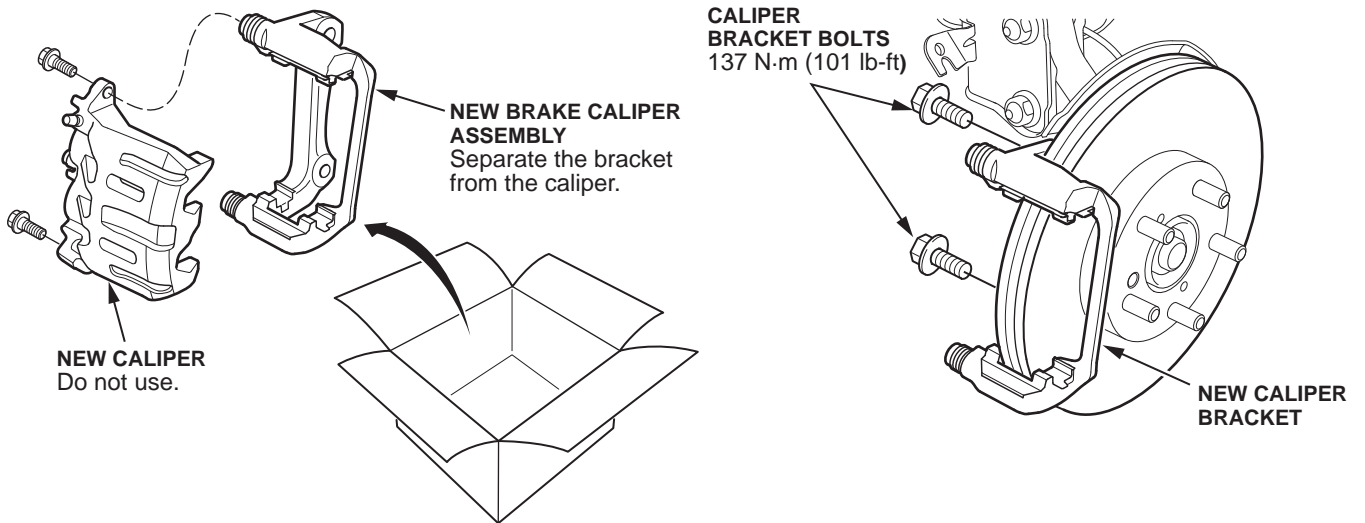

12. Install the new brake caliper bracket and torque the bolts to **137 N-m (101 lb-ft)**.

13. Apply a thin coat of M-77 assembly paste to the retainer mating surface of the brake pad.

NOTE: Keep grease and assembly paste away from the brake disc and brake pad surface. Contaminated brake disc or brake pads reduce stopping ability.

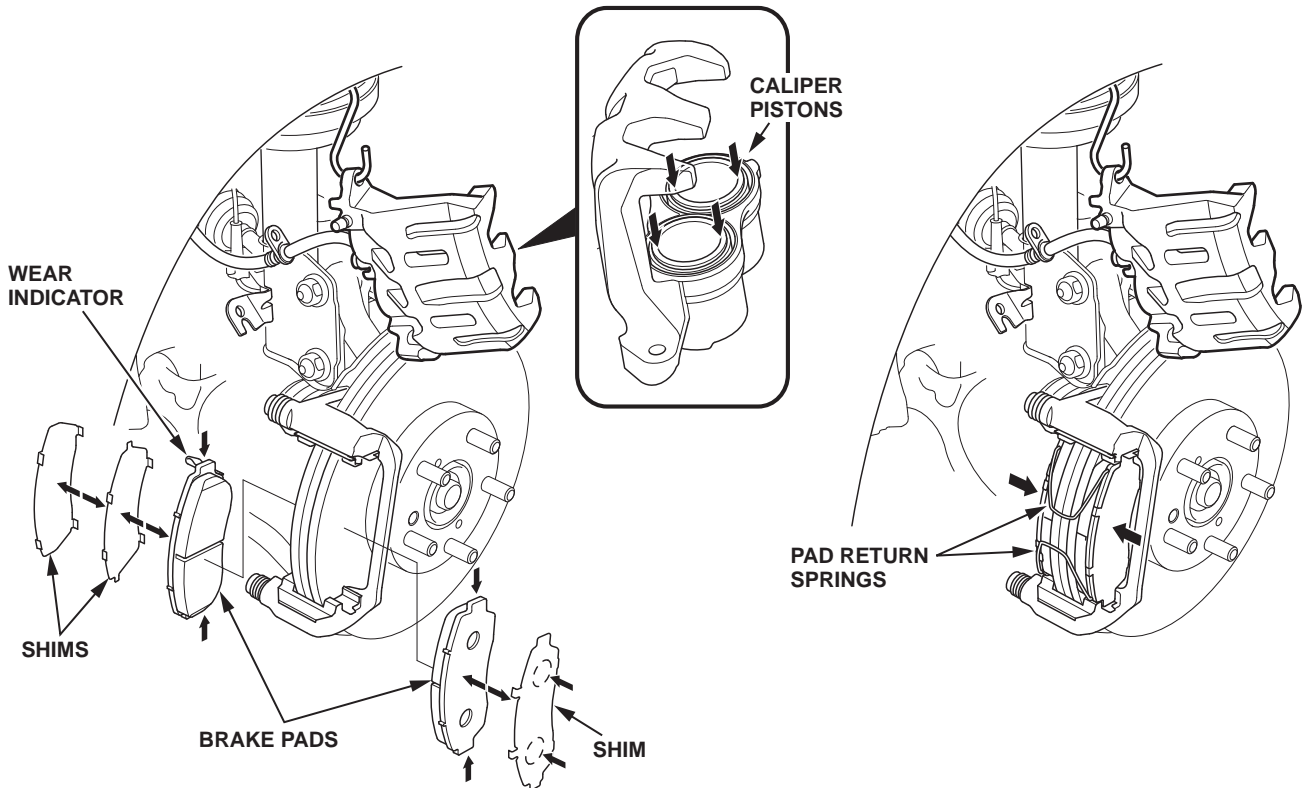

14. Install the original brake pads with the wear indicator on the upper inside position on the new caliper bracket.
15. While holding the brake pads, insert the pad return spring ends into the pad installation holes securely.
16. Install the original caliper onto the bracket. Hold the caliper pin with a wrench and install the flange bolts, and torque them to **50 N·m (37 lb-ft)** being careful not to damage the pin boot.

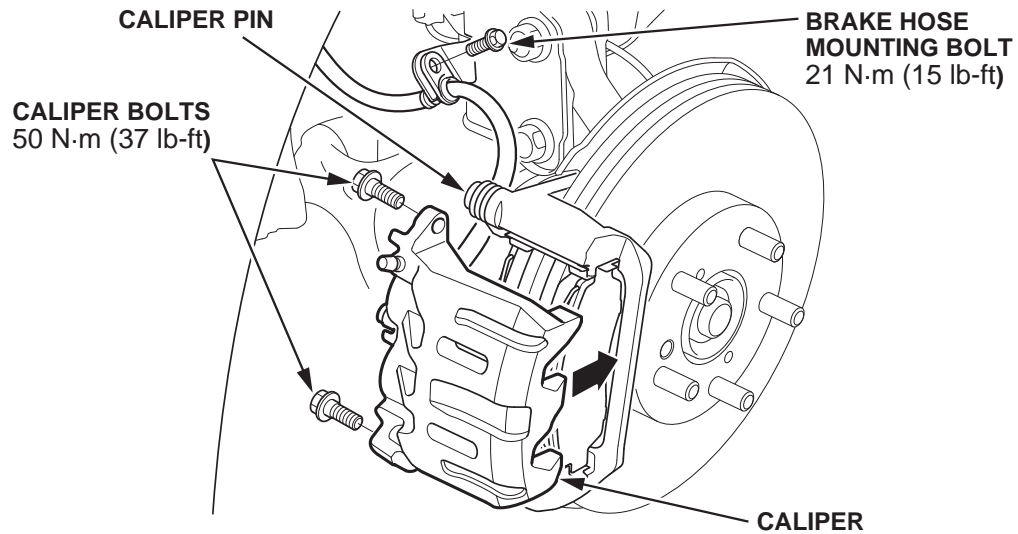

17. Install the brake hose mounting bolt and torque them to **21 N·m (15 lb-ft)**.
18. Clean the mating surfaces between the brake disc and the inside of the wheel, then install the front wheels.

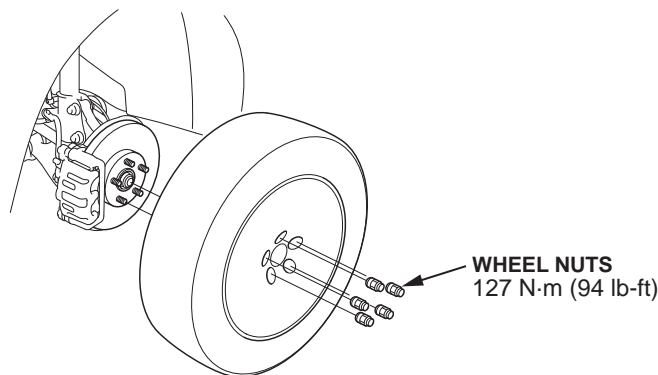

19. Press the brake pedal several times to make sure the brakes work.

END