

FLA COE  
 FLB COE  
 > FLD Conventional  
 Business Class  
 FLC 112 Conventional

> Century Class Conventional  
 > Argosy COE  
 Cargo  
 > Columbia

122SD and Coronado  
 > Business Class M2  
 > Cascadia  
 108SD/114SD

**Description of Revision:** *This bulletin replaces the version dated July 2010. For this version, the pre-approval instructions and the QuickClaim table were removed, model year information was added to General Information, and the breather part number was updated.*

**General Information**

On vehicles produced before model year 2009 (MY09) and equipped with Freightliner (also known as Detroit™) tandem rear axles, there may be an oil leak from the external breather on the forward-rear differential carrier. An internal breather is available for installation to remedy such a leak. See Fig. 1. If there is an oil leak from the external breather, remove the differential carrier and install the internal breather, following the instructions in this bulletin.

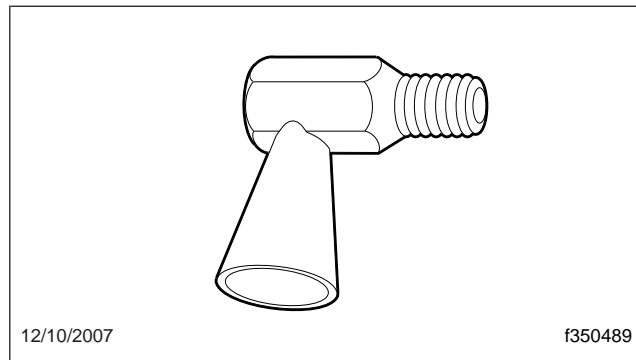

**Fig. 1, Internal Breather**

**Part Required**

The internal breather (see Table 1) is available through drop shipment only. Please specify overnight shipping when placing the order.

Part Required		
Part Number	Description	Qty.
MBA 6073510065	Breather, Internal	1

**Table 1, Part Required**

**Breather Installation Procedure**

1. Park the vehicle on a level surface, shut down the engine, set the parking brake, and chock the front tires.
2. Put the transmission in neutral.
3. If applicable, release the suspension air pressure.

**WARNING**

**Never work around or under a vehicle that is supported only by a jack. Always support the vehicle with safety stands. Jacks can slip, causing the vehicle to fall, which could result in serious injury or death.**

**Freightliner  
Service Bulletin**

FLA COE  
FLB COE  
> FLD Conventional  
Business Class  
FLC 112 Conventional

> Century Class Conventional  
> Argosy COE  
Cargo  
> Columbia

122SD and Coronado  
> Business Class M2  
> Cascadia  
108SD/114SD

4. Using suitable jacks, raise the vehicle evenly until there is room to fit a jack underneath the axle housing. Support the vehicle with safety stands.
5. Remove the tires and wheels. For instructions, see **Group 40** in the applicable vehicle workshop manual.
6. Remove the oil drain plug from the bottom of the axle housing and drain the oil. Install the drain plug after emptying.
7. Disconnect the driveshaft from the carrier yoke. For instructions, see **Group 41** in the applicable vehicle workshop manual. Using suitable straps, support the end of the driveshaft by attaching it to the frame rail.
8. Place a basin under the axle shaft flanges to catch any oil; then remove the axle shafts as follows.
  - 8.1 Remove the drive axle stud nuts that attach the axle shaft to the wheel hub.
  - 8.2 Tap the axle shaft flange if necessary to loosen it, and slide the axle shaft out of the axle. Remove and discard the gasket.
9. Using a suitable jack, support the differential carrier. Chain the differential carrier to the jack.

---

**NOTICE**

---

**When using a pry bar, be careful not to damage the carrier or housing flange. Damage to these surfaces will cause oil leaks.**

10. Remove the differential carrier from the axle housing as follows.
  - 10.1 Remove all but the top two forward carrier capscrews.
 

NOTE: Loosen and back off, but do not remove, the top two carrier capscrews. The capscrews will hold the carrier in the housing.
  - 10.2 Using a pry bar with a round end, separate the mating surfaces of the forward differential carrier and axle housing.
  - 10.3 When the surfaces are separated, remove the top two capscrews.
  - 10.4 With the carrier on the jack, slide the carrier away from the rear axle housing.

 **WARNING**

**The differential carrier is very heavy. Do not try to remove it without a suitable support. To do so could result in the carrier falling, resulting in serious personal injury and component damage.**

- 10.5 Lift the carrier assembly onto a suitable stand.

---

**NOTICE**

---

**If the area around the breather hole is recessed instead of flush (see [Fig. 2](#)), do not install the internal breather.**

11. Using a hammer, install the internal breather (cone pointing down) in the breather hole inside the carrier that connects to the external breather. See [Fig. 3](#) and [Fig. 4](#).
 

Tap the breather in until it seats; but no more, or you could loosen it.
12. Remove any old sealant material from the mating surfaces of the axle housing. Clean the inside of the rear axle housing and the forward carrier mating surface.

FLA COE  
FLB COE  
> FLD Conventional  
Business Class  
FLC 112 Conventional

> Century Class Conventional  
> Argosy COE  
Cargo  
> Columbia

122SD and Coronado  
> Business Class M2  
> Cascadia  
108SD/114SD

**Freightliner  
Service Bulletin**

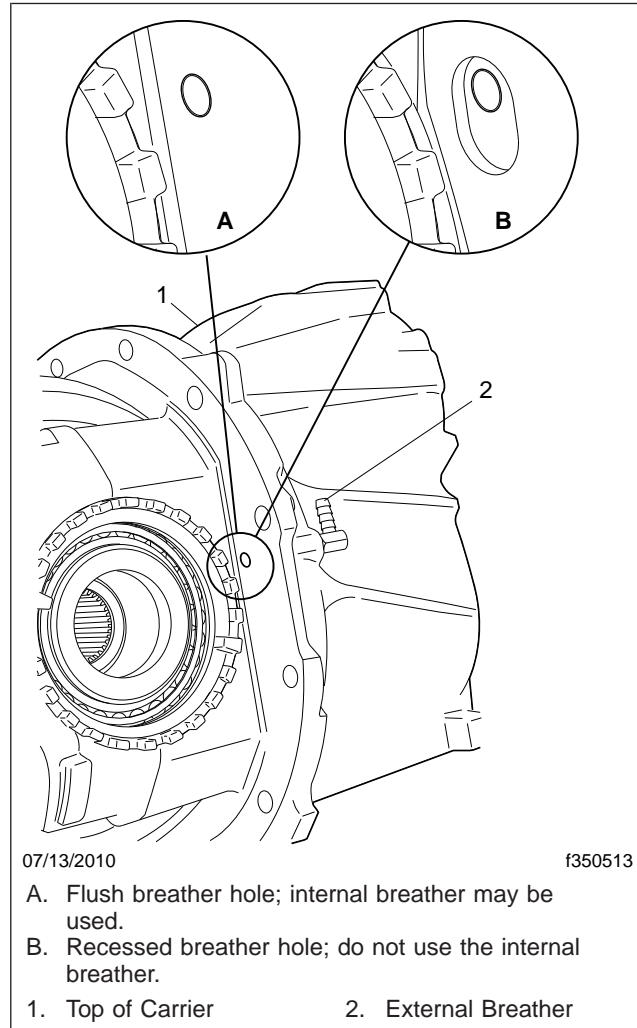

**Fig. 2, Breather Hole Configurations**

13. Apply a thin bead of Loctite® 5900 sealant all the way around the mating surface of the axle housing, and around each bolt hole.

NOTE: Alignment dowels for installing the differential carrier can be made by sawing off the heads of two M16 x 1.5 x 100 mm bolts.

14. Install alignment dowels 180 degrees apart at the 3 o'clock and 9 o'clock positions on the axle housing flange.

15. Position the forward differential carrier in front of the axle housing, using an axle jack or other suitable lifting tool.

### Freightliner Service Bulletin

FLA COE  
FLB COE  
> FLD Conventional  
Business Class  
FLC 112 Conventional

> Century Class Conventional  
> Argosy COE  
Cargo  
> Columbia

122SD and Coronado  
> Business Class M2  
> Cascadia  
108SD/114SD

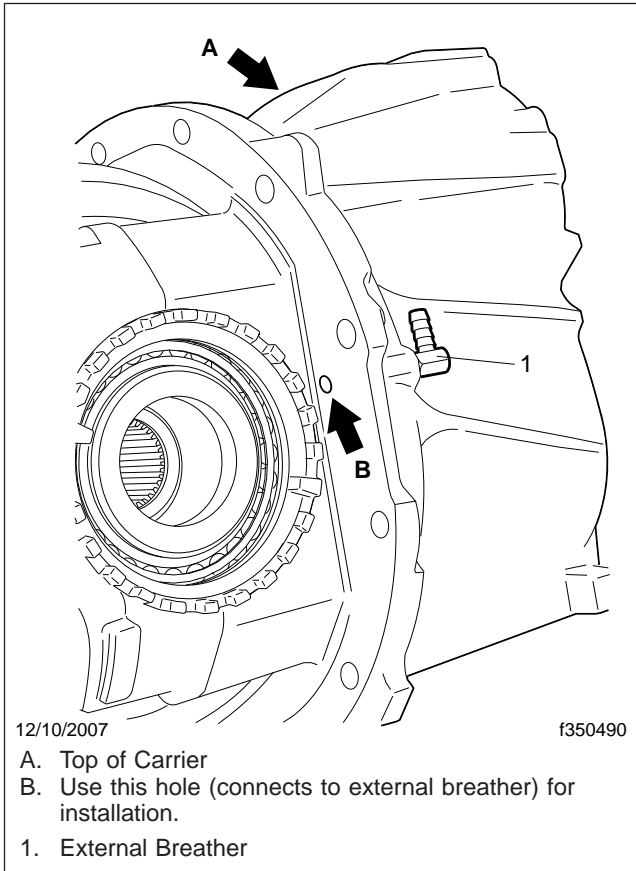

**Fig. 3, Location of Breather Hole**

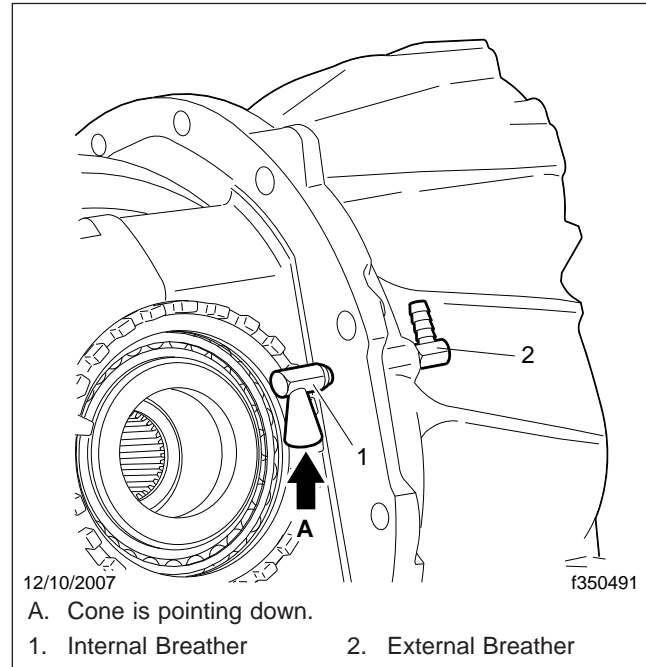

**Fig. 4, Internal Breather Installed**

### NOTICE

**Do not use a hammer or a mallet to install the differential carrier. A hammer or a mallet will damage the mounting flange of the carrier and cause oil leaks.**

16. Install the end caps on the sides of the forward differential carrier into the corresponding slots in the axle housing as follows. See [Fig. 5](#).
  - 16.1 For the last 3/4 inch (19 mm) or so of travel, walk the carrier slowly into the housing.

**IMPORTANT:** The end caps fit tightly into the axle housing. Be very careful not to cock the carrier.

  - 16.2 Install the forward carrier capscrews finger-tight. Make sure the carrier capscrews turn easily in the axle housing.
  - 16.3 In a star pattern, gradually tighten the M16 forward carrier capscrews 200 lbf-ft (270 N-m).
17. Connect the driveshaft to the carrier yoke. For instructions, see **Group 41** in the applicable vehicle workshop manual.
18. Install the axle shafts as follows.
  - 18.1 On one side of the vehicle, position a new gasket on the axle shaft flange.

FLA COE  
 FLB COE  
 > FLD Conventional  
 Business Class  
 FLC 112 Conventional

> Century Class Conventional  
 > Argosy COE  
 Cargo  
 > Columbia

122SD and Coronado  
 > Business Class M2  
 > Cascadia  
 108SD/114SD

18.2 Slide the axle shaft into the axle. See **Fig. 6**.

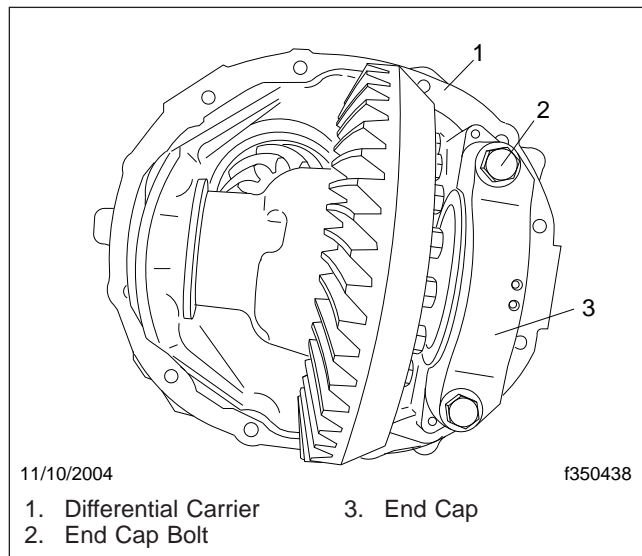

**Fig. 5, Carrier End Caps**

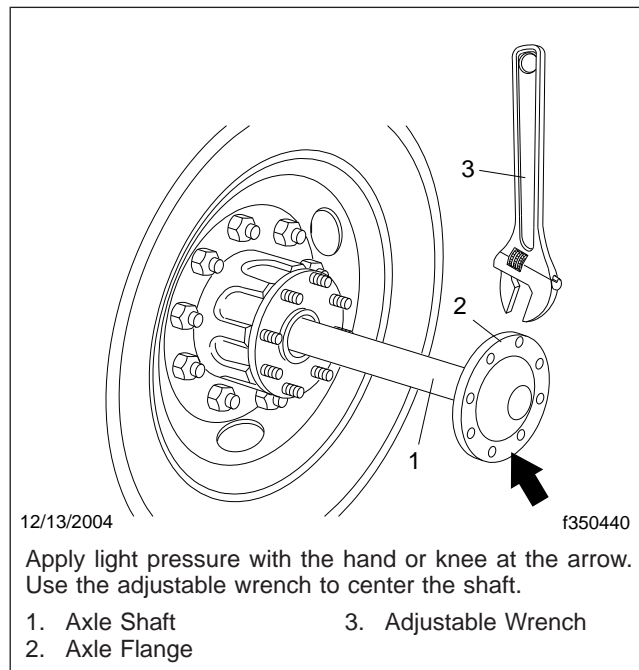

**Fig. 6, Installing the Axle Shaft**

18.3 Apply light pressure with the hand or knee to the axle flange.

18.4 Use an adjustable wrench to center the shaft. Turn the shaft with a slight rotating motion.

18.5 Install the drive axle stud nuts and tighten them as follows:

- ½–20 nuts: 75 to 115 lbf·ft (102 to 156 N·m)
- 5/8–18 nuts: 150 to 170 lbf·ft (203 to 230 N·m)

18.6 Repeat the procedure on the other side of the vehicle.

19. Install the wheels and tires. For instructions, see **Group 40** in the applicable vehicle workshop manual.

20. Using approved axle oil, fill the axle housing to the bottom of the fill hole, or until filled to capacity as shown in **Table 2**.

Approved Forward Carrier Axle Oil Type and Capacity		
Oil Type	Capacity: quarts (liters)	
	Hubs Full	Hubs Dry
80W-90 Gear Oil	14.3 (13.5)	15.9 (15.0)
75W-90 Synthetic Gear Oil		

**Table 2, Approved Forward Carrier Axle Oil Type and Capacity**

### Freightliner Service Bulletin

FLA COE  
FLB COE  
> FLD Conventional  
Business Class  
FLC 112 Conventional

> Century Class Conventional  
> Argosy COE  
Cargo  
> Columbia

122SD and Coronado  
> Business Class M2  
> Cascadia  
108SD/114SD

21. To lubricate the wheel ends, tilt the axle to the left and right by jacking the opposite side 8 inches (20 cm). Hold the tilted position for two minutes on each side to allow oil to run into the wheel end. Return the axle to a level position, and add oil through the axle housing filler hole. About two more pints (1 liter) of lubricant will be needed to bring the oil level even with the base of the filler hole.

### NOTICE

**Make sure the hubs are filled. Driving with the hubs dry will cause bearing damage.**

22. Raise the vehicle, remove the safety stands, then lower the vehicle.
23. As applicable, start the engine, build the air pressure, and check that the suspension air bags inflate evenly and correctly. Make sure the ride height is correct.
24. Check the oil level in the axle housing. The level should be up to the bottom of the fill hole. Add approved axle oil, if needed.
25. Remove the chocks from the front tires.

### Warranty

Normal warranty applies. See [Table 3](#) for VMRS code and labor allowance information, and refer to this bulletin by number in the story of the claim.

OWL VMRS Codes and Labor Allowance				
Component Code	Cause Code	SRT Code	Description	Time: Hours
022-004-126	12	420-5055A	Breather, Differential Carrier Internal, Install	4.3

**Table 3, OWL VMRS Codes and Labor Allowance**