

# UPDATE Technical Bulletin



## SB-10056475-8696

August 4, 2014

### UPDATE – 97AS Driver Seat Harness (NVLW)

**NOTE:**

- Perform this UPDATE on all applicable vehicles within NEW VEHICLE LIMITED WARRANTY.
- It is MANDATORY to perform UPDATES on all applicable vehicles in dealer inventory PRIOR TO RETAIL SALE.
- Inform customers that this UPDATE will be available free of charge as long as their vehicle is within the Warranty parameters outlined in this UPDATE.

**NOTE:**

**Required DMS Wording/Text: (line item, customer concern description on repair order):**

UPDATE 97AS Driver Seat Harness (NVLW)

Model(s)	Year	Engine Code	Trans. Code
Golf, GTI	2015	All	All

REVISION HISTORY		
Revision	Date	Purpose
1	August 4, 2014	Original publication

## Condition

This update has been proactively released to prevent damage to the wiring harness for the driver seat.

This UPDATE is in effect until removed.

Vehicle must meet all of the following criteria:

- Procedure is valid only for vehicles that show the 97AS code in Elsa, Campaign/Action Information screen on the day of repair.
- If the vehicle is sold it must be within the NEW VEHICLE LIMITED WARRANTY.
- Procedure must be performed within the allotted time frame stated in this UPDATE.
- Procedure must be performed on applicable vehicles in dealer inventory prior to sale.

## Technical Background

During vehicle production, the driver side power seat harness as it connects to the vehicle may have been incorrectly routed. Damage to the harness for the driver side power seat can occur during operation of the seat adjustments.

## Production Solution

Correct routing of harness in production as of CW27

## Service

### NOTE:

- *Elsa is the only valid inquiry/verification source. Check Elsa on the day this vehicle UPDATE will be performed to verify vehicle eligibility for the UPDATE. Status must show "open". Attach an Elsa printout showing the "open" status to the repair order.*
- *If this UPDATE appears to have already been performed but the code still shows open in Elsa, contact Warranty before proceeding further. Another dealer may have recently performed this UPDATE but not yet entered a claim for it in the system.*
- *Elsa may also show additional open action(s); if so, inform your customer - this work can be done while the vehicle is in for this UPDATE.*
- *Contact the Warranty Helpline (U.S.) or the Warranty Campaign Specialist (Canada) if you have any questions.*



Applicable Criteria ID (s)	Campaign/Action Status
01	Open

**EXAMPLE**

## Section A – Check for Previous Repair

- Enter the VIN in Elsa and proceed to the “Campaign/Action” screen



Tip: On the date of repair, print this screen and keep a copy with the repair order

← Ensure that the Status is “Open”  
<arrow 2>

- Note the Applicable Criteria ID  
<arrow 1> for use in determining the correct work to be done and corresponding parts associated.

## Continue to Section B

### Section B - Inspection of Driver Seat Wiring Harness Routing

- Raise the driver seat to the full-upward position.
- Inspect the routing of the wiring harness as illustrated below.

**Scenario #1** – The wire harness is routed correctly, no further repairs are required.

**Scenario #2** – The wire harness is routed incorrectly with **NO** visible damage to the wiring harness – disconnect and reroute the wiring harness.

**Scenario #3** – The wire harness is routed incorrectly and there is visible damage to the wiring harness– replace the wiring harness.

# UPDATE Technical Bulletin



Das Auto.

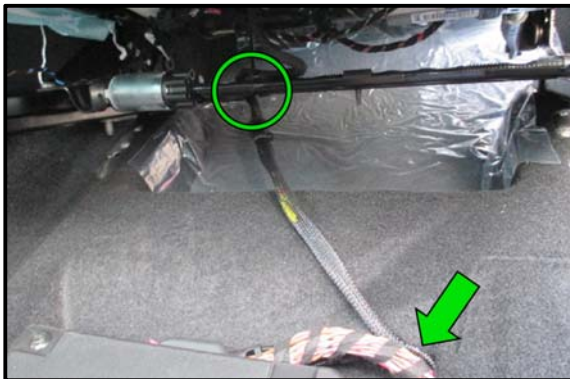

⇐ The wiring harness must be routed through the carpet on the inboard side of the access panel <arrow>, then **under** the seat frame as shown <circle>.

- If the harness is routed as pictured, the routing is **correct – Work Complete**
- If the harness is not routed as pictured, the routing is **incorrect**. Inspect the wiring harness for any visible damage.
  - If no damage is found, **Proceed to Section C – Seat Harness Re-routing.**
  - If damage is found, **Proceed to Section D – Seat Harness Replacement.**



Tip: If rubber bands are found on the wire harness or seat frame <circles>, they can be removed and discarded.

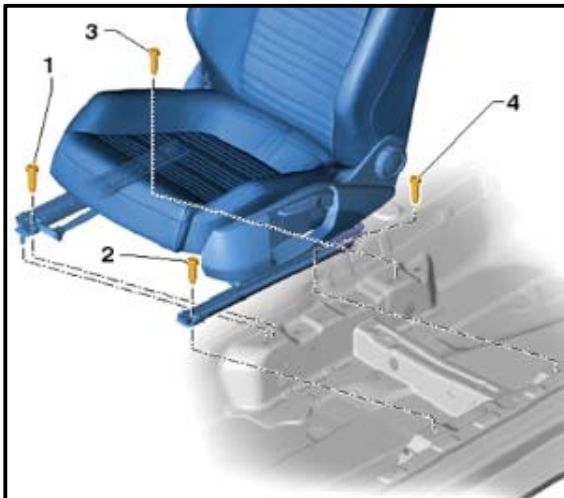

## Section C – Seat Harness Re-Routing

- Move the driver front seat to the full forward position.
- ⇐ Remove the rear mounting bolts <3 and 4>.
- Move the seat to the full rearward position.
- ⇐ Remove the front mounting bolts <1 and 2>.

- Tilt the driver seat onto its back carefully.



 Note: Monitor the slack in the seat harness between the seat and the floor connectors during this step. It may be necessary to adjust the seat to avoid damaging the wiring harness.

- ⇐ Remove the mounting clip <circle> from the carpet access panel.

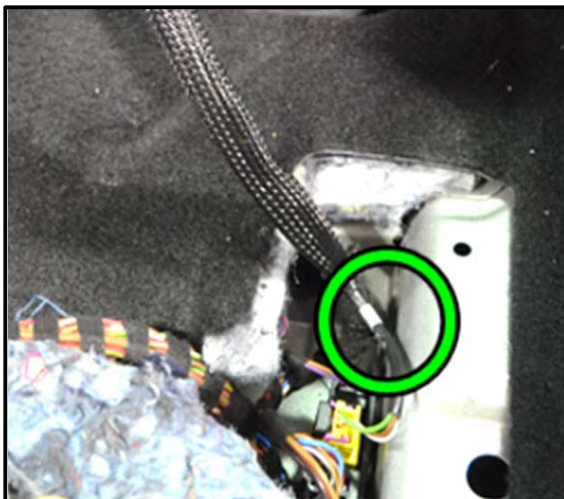

 **WARNING:** DO NOT disconnect any of the electrical connectors during this step.

- Open the carpet access panel.
- ⇐ Release the driver seat harness floor anchor <circle> to allow for additional slack in the harness.

 Tip: The seat can be adjusted as necessary after this step to allow for easier access to the wiring harness and under-seat area.

# UPDATE Technical Bulletin



- Open the hood.
- Open the battery cover.
- ⇐ Disconnect and isolate the negative battery cable <circle>.



- Disconnect all three electrical connectors under the carpet access panel.
- ⇐ Install the Airbag Lockout Adapter - VAS6282- onto the airbag connector <as shown>.

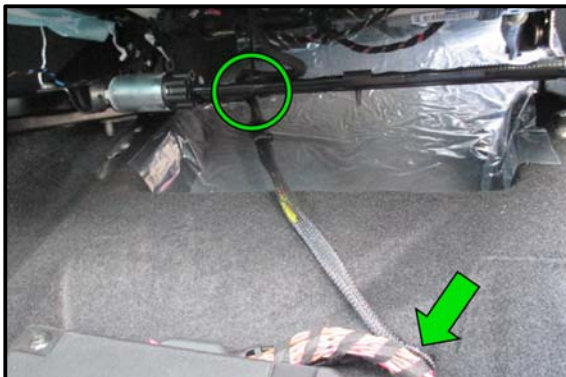

- Re-route the wiring harness through the correct access hole in the carpet.
- ⇐ The wiring harness must be routed through the carpet on the inboard side of the access panel <arrow>, then **under** the seat frame as shown <circle>.
- Remove the Airbag Lockout Adapter - VAS6282 from the airbag wiring harness.

- Reconnect all three electrical connectors under the driver seat.
- Close and refasten the carpet access panel.
- Reinstall the driver seat and **torque the mounting bolts to 65Nm.**
- Reconnect the vehicle battery.
- Use an appropriate VAS tester to clear all DTC's.
- Close the hood.

## Work Complete

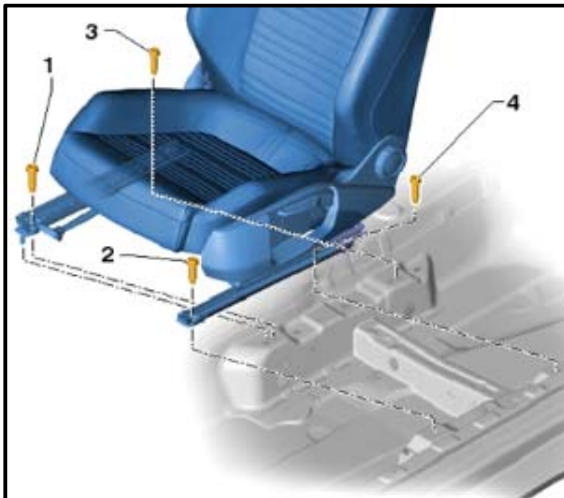

## Section D – Seat Harness Replacement

- Move the driver front seat to the full forward position.
- ⇐ Remove the rear mounting bolts <3 and 4>.
- Move the seat to the full rearward position.
- ⇐ Remove the front mounting bolts <1 and 2>.
- Tilt the driver seat onto its back carefully.



Note: Monitor the slack in the seat harness between the seat and the floor connectors during this step. It may be necessary to adjust the seat to avoid damaging the wiring harness.

# UPDATE Technical Bulletin



⇐ Remove the mounting clip <circle> from the carpet access panel.



- Open the carpet access panel.
- ⇐ Release the driver seat harness floor anchor <circle> to allow for additional slack in the harness.



Tip: Adjust the seat as necessary after this step to allow for easier access to the wiring harness and under-seat area.



**WARNING:** DO NOT disconnect any of the electrical connectors during this step.



- Open the hood.
- Open the battery cover.
- ⇐ Disconnect and isolate the negative battery cable <circle>.





- Disconnect all three electrical connectors under the carpet access panel.
- ⇐ Install the Airbag Lockout Adapter - VAS6282- onto the airbag connector <as shown>.



- ⇐ If present, remove the tie wraps from each end of the mesh wiring loom <arrows>.

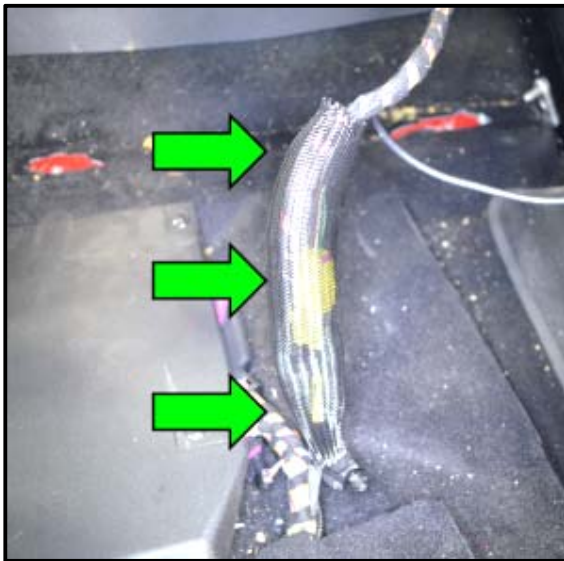

- ⇐ Compress the mesh wiring loom ends together as shown <arrows>.
- ⇐ Separate the airbag wiring harness from the main seat harness by sliding the airbag connector and harness through the mesh wiring loom <as shown>.

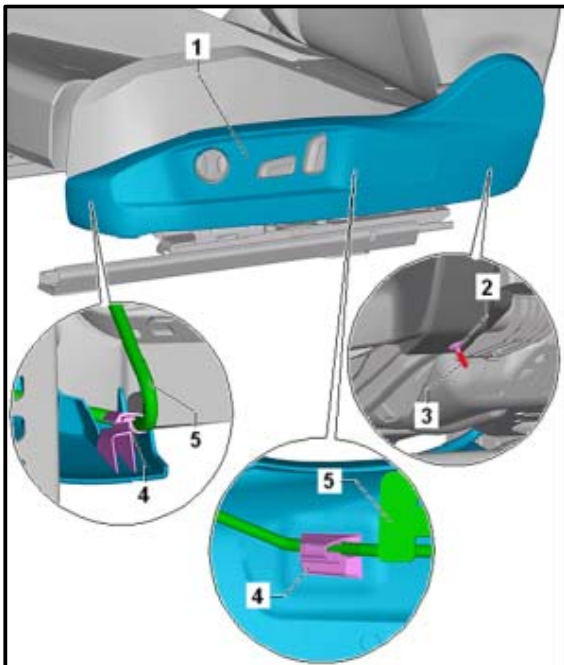

- ⇐ Press center of plastic rivet <3> toward the inside of the seat to release it.
- ⇐ Remove the plastic rivet <2> using trim removal wedge VAG 3409.
- ⇐ Release the two mounting clips <4> from the back side of the trim panel <1>.
- Carefully unfasten and remove the trim panel from the seat frame.
- Disconnect the electrical connectors from the seat switches and fully remove the trim panel from the seat.



Tip: It may be necessary to reposition the seat slightly to allow adequate working space between the seat and the driver side B-pillar.

# UPDATE Technical Bulletin

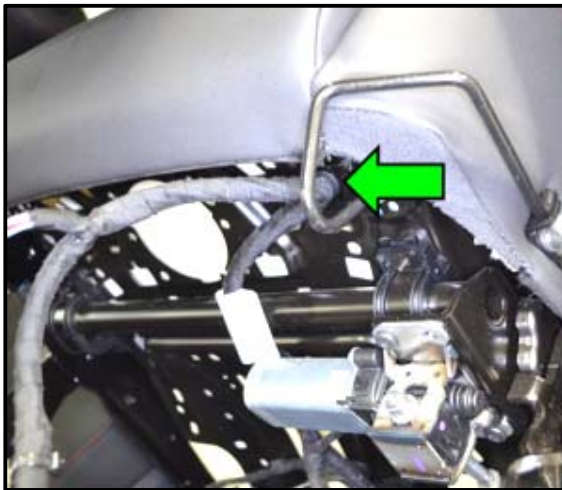

- ⇐ Re-route the seat harness as shown <arrow> to reposition the seat switch pigtail inside the seat trim bracket.
- Working backward from the seat switch segment of the wiring harness, unfasten each mounting clip, and disconnect each connector on the seat harness.



Tip: Take a picture with a digital camera, cell phone, etc. of the wiring harness prior to disassembly. This can be referenced during reassembly to ensure proper harness routing.

- Remove the seat harness from the driver seat.
- Install the replacement seat wiring harness, P/N 5GM 971 391E as the old harness is removed to ensure proper routing and placement.

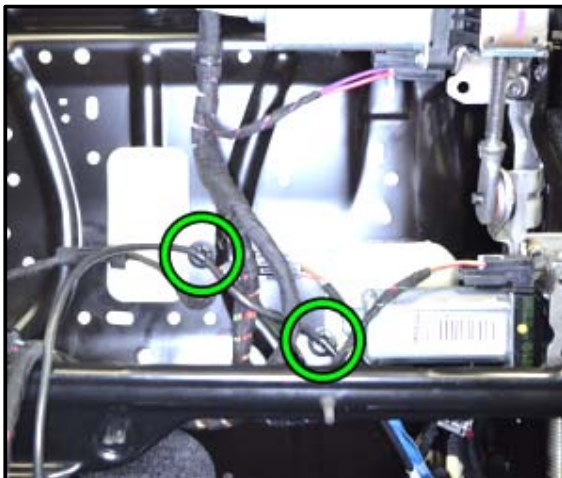

- ⇐ During harness removal, it may be necessary to unfasten the two airbag wiring harness mounting clips <circles>.



Note: Be sure to refasten all wiring harness mounting clips during reassembly.

# UPDATE Technical Bulletin



Das Auto.

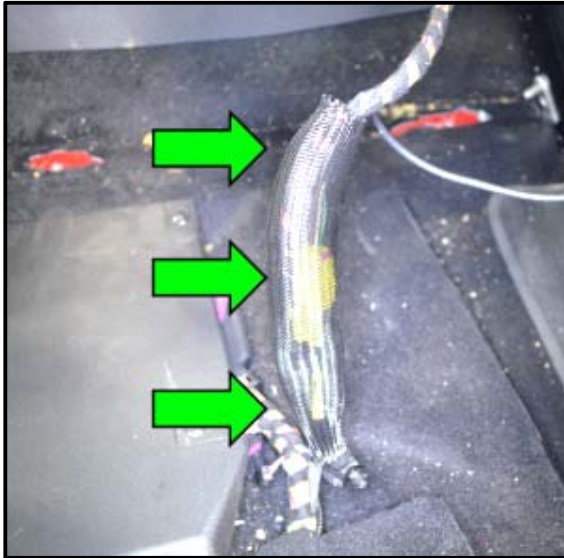

⇐ Reinsert the airbag wiring circuit through the mesh wiring loom <arrows>.



⇐ Reinstall the tie wraps onto each end of the mesh wiring loom <arrows>.

# UPDATE Technical Bulletin

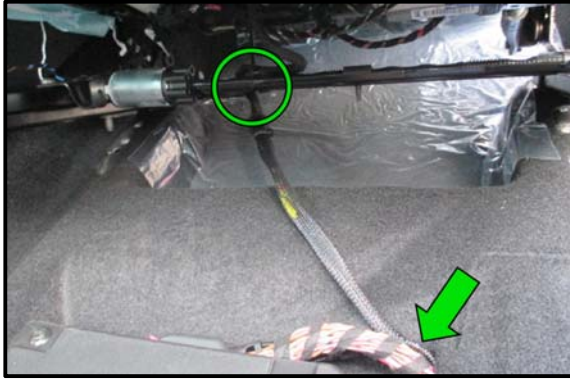

- Remove the Airbag Lockout Adapter - VAS6282 from the airbag wiring harness.
- Reconnect all three electrical connectors under the driver seat.
- ⇐ Route the harness through the carpet on the inboard side of the access panel <arrow>, then **under** the seat frame as shown <circle>.
- Close and refasten the carpet access panel.
- Reinstall the driver seat and **torque the mounting bolts to 65Nm.**
- Reconnect the vehicle battery.
- Use an appropriate VAS tester to clear all DTC's.
- Close the hood.

**Work Complete**

## Warranty

<b>Claim Entry Procedure</b>	Enter your claim immediately upon completion of the UPDATE. Claims will only be paid for vehicles that show this UPDATE code open in Elsa on the day of repair. To help ensure prompt and proper payment, attach the screen print to the repair order.
<b>Claim Help</b>	<p><b>U.S. dealers</b> - Contact the <b>Warranty Helpline</b> toll-free at 1-866-306-8447 for help with claim entry.</p> <p><b>Canadian dealers</b> - Contact your Warranty Campaign Specialist. For contact information, please proceed to "ServiceNet – Warranty/Contact Information/Campaigns – "Warranty Campaign Specialist."</p>
<b>Required Customer Notification</b>	<p>Ensure customers are aware of all work performed on the vehicle by recording the information on the repair order.</p> <p>Attach a copy of the <i>Vehicle UPDATE Fact Sheet</i> to the customer's copy of the repair order and take the time to explain this UPDATE to your customer.</p>

# UPDATE Technical Bulletin



Das Auto.

## SAGA Code 97AS Claim Entry Procedure

Check Elsa to confirm that this UPDATE code is open on the day of repair.

Service No.: 97AS

Damage Code: 0099

Parts Manufacturer/Vendor Code: WWO

### Claim Type

Sold vehicle = 7 10

Unsold vehicle = 7 90

### Accounting Instructions

Criteria I.D. 01

Check driver seat harness. Correct routing present. No further work required.

Repair operation: 0183 00 99 10 TU

-- OR --

Check driver seat harness. No damage found, but incorrect routing present. Properly route driver seat harness.

Repair operation: 9757 05 99 30 TU

-- OR --

Check driver seat harness, damage found. Replace driver seat harness.

Repair operation: 9757 55 99 70 TU

<u>Quantity</u>	<u>Part Number</u>	<u>Part Description</u>
Up to 1	5GM 971 391 E	Driver Seat Harness

***There is NO reimbursement for wash or loaner vehicle!***

**If the vehicle is outside of the specified warranty period OR if customer refused repairs.**

**U.S. dealers:** Submit the request through WISE under the Campaigns/Update/Recall Closure option.

**Canadian dealers:** Fax the Repair Order to Warranty at (905) 428-4811 and provide VIN, applicable Service Number, Customer Information, Dealer Number and Date.

## Required Parts and Tools

Part Description	Part No:	Quantity
Driver Seat Harness	5GM 971 391 E	1

Tool Description	Tool No:	Quantity
Airbag Lockout Adapter	VAS6282	1
Torque Wrench 5-50Nm	VAG 1331	1
Trim removal wedge	VAG 3409	1

## Additional Information

All part and service references provided in this Technical Bulletin are subject to change and/or removal. Always check Elsa for the most current version of this document.

# UPDATE Technical Bulletin



Das Auto.

---

## UPDATE FACT SHEET – UPDATE Code 97AS

Dear Volkswagen Customer,

Today we performed UPDATE code 97AS on your vehicle. This UPDATE was performed to verify the proper routing and if necessary, replace the wiring harness for the driver seat. This UPDATE was performed for you free of charge.

Volkswagen periodically makes updates like this available in order to ensure our customer's continued satisfaction with the quality of their Volkswagen vehicles.

We at Volkswagen are committed to providing our customers with reliable, quality products that are a pleasure to drive and own. If you should ever have any questions or vehicle concerns, your authorized Volkswagen dealer will be pleased to assist you.

Thank you for driving a Volkswagen!





Das Auto.

## VOLKSWAGEN DEALERSHIP COMMUNICATION

Date: August 01, 2014

To: Dealer Principal, Sales Manager, Service Manager, Parts Manager and Warranty Administrator

Subject: Upcoming UPDATE 97AS – Driver Seat Harness  
2015 MY Golf/GTI

### IMPORTANT NOTICE TO DEALERS - FOR IMMEDIATE DISTRIBUTION

## Upcoming UPDATE 97AS

Dear Volkswagen Dealer Principal, Service Manager, and Parts Manager:

This is to inform you of an upcoming UPDATE that will be visible in Elsa and ServiceNet on or about August 04, 2014.

Please refer to the Elsa campaign/action screen for confirmation of whether the UPDATE applies to each specific vehicle, and look to Elsa and ServiceNet for additional information and complete repair instructions.

Consistent with general Volkswagen corporate policy governing UPDATES, Volkswagen is not notifying consumers. (UPDATES differ from recalls and service actions; consumers are notified in writing of recalls and service actions.) Each vehicle should be completed when it is in to the dealer for maintenance or any other service visit. Dealer stock vehicles **cannot, however, be delivered** to consumers until the UPDATE is completed.

To identify any vehicles in your inventory that are affected by this UPDATE, please run the “New and CPO Inventory Open Campaign/Action Listing” report from the VIM system.

Please ensure that every affected vehicle gets the update before delivery to consumers. Your effort is integral in reaching the highest quality expectations of Volkswagen customers.

If you have any questions or require additional assistance, please contact Warranty.

Volkswagen Product Compliance

Attachment: UPDATE Data Sheet (1)



Das Auto.

## UPDATE DATA SHEET

<b>SAGA CODE</b>	<b>97AS</b>
<b>MARKET(S)</b>	United States and Canada
<b>AFFECTED VEHICLES</b>	2015 MY Golf/GTI
<b>ELSA &amp; VIM VISIBILITY DATE</b>	On or about August 04, 2014
<b>TOPIC</b>	Driver Seat Harness
<b>PROBLEM DESCRIPTION</b>	During vehicle production, the driver side power seat harness as it connects to the vehicle may have been incorrectly routed. Damage to the harness for the driver side power seat can occur during operation of the seat adjustments.
<b>CORRECTIVE ACTION</b>	Inspect seat harness for damage, reroute or replace if necessary.
<b>VEHICLE WARRANTY PARAMETER</b>	NVLW
<b>VEHICLE COUNT</b>	<b>TOTAL AFFECTED</b> USA: 1,636 Canada: 1,331
	<b>DEALER INVENTORY</b> USA: Approximately 563 Canada: Approximately 521
	<b>CPO INVENTORY</b> USA: 0 Canada: 0
<b>APPROXIMATE REPAIR TIME</b>	Up to 70 TU
<b>SPECIAL TOOLS NEEDED?</b>	SEE UPDATE TECHNICAL BULLETIN
<b>PARTS REQUIRED</b>	SEE UPDATE TECHNICAL BULLETIN
<b>INITIAL PARTS ALLOCATION DATE</b>	N/A. Expected replacement rate does not meet minimum requirements for dealer allocation. Only if part is necessary, please email VW Special Services with VIN to order.
<b>ADDITIONAL INFORMATION</b>	Please ensure that this UPDATE is performed on every applicable vehicle before delivery to consumers. Your effort is integral in reaching the highest quality expectations of Volkswagen customers.  Please reinforce the correct repair description of this action with all dealership personnel – this action is a vehicle <b>UPDATE</b> , <i>not</i> a recall.

**IMPORTANT!** To ensure that ALL of your personnel are aware of this action before receiving questions from any customer, please share this information with ALL personnel who have campaign-related responsibilities, including service writers, technicians, parts employees, warranty administrators, etc. See the campaign circular on Elsa for the most current repair information. Refer to the campaign circular for complete repair and claiming instructions.