

Technical Service Bulletin



21E7 UPDATE – Turbocharger (NVLW)

August 5, 2014

SB-10056439-1712

Model(s)	Year	VIN Range	Vehicle-Specific Equipment
A3	2015	See Campaign/Action screen in Elsa	CNTC (2.0L)

Condition

This Update has been proactively released to prevent the following condition from occurring in the vehicle:

On Audi A3 vehicles manufactured within a specific period the turbocharger may fail causing the MIL to illuminate.

This Update is in effect until removed.

Vehicle must meet all of the following criteria:

- Procedure is valid only for vehicles that show the **21E7** code in the Elsa Campaign/Action Information screen on the day of repair.
- Vehicle must be within the New Vehicle Limited Warranty.
- Procedure must be performed within the allotted time frame stated in this Technical Service Bulletin.
- Procedure must be performed on applicable vehicles in dealer inventory prior to sale.

Technical Background

On Audi A3 vehicles manufactured within a specific period the turbocharger may fail causing the MIL to illuminate.

Technical Service Bulletin



Service

Removal



Caution

Danger of malfunction caused by dirt.
Observe Clean Working Conditions.

- Drain the coolant.
- Remove the air filter housing.
- Remove the Heated Oxygen Sensor - G39-
- Remove the bolt <2> and the screw-type clamp.
- Remove the nuts <1> and <3> and move the catalytic convert to the side. Ignore item <4>



Note

The installed position is shown in the illustration with the engine removed.

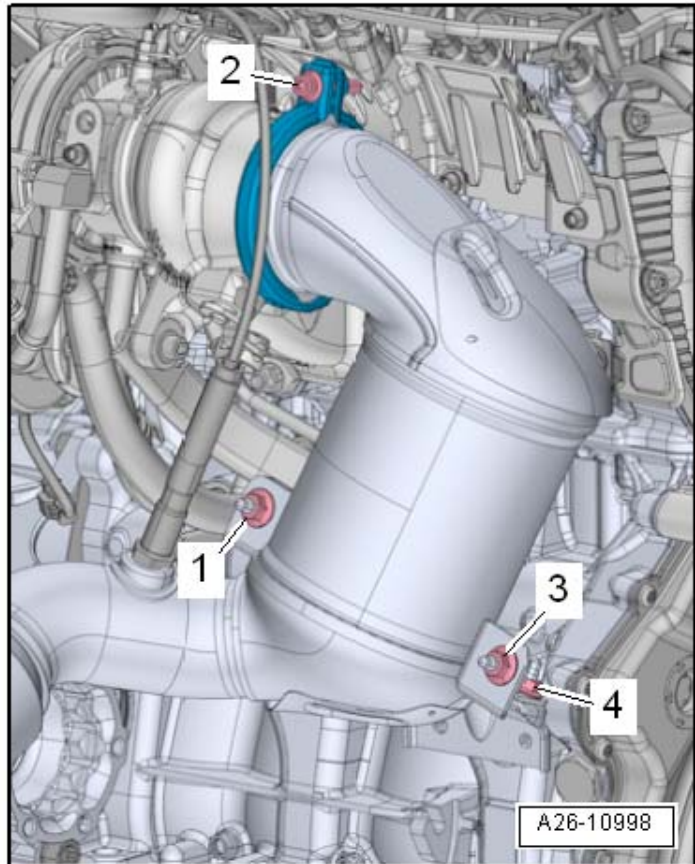

Technical Service Bulletin



Audi

- Loosen the hose clamp <2>.
- Remove bolt <1> and push the left air guide pipe left.

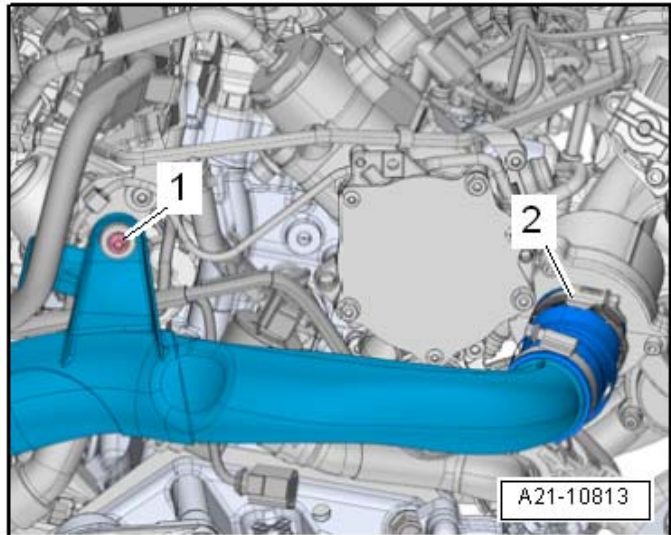

- Disconnect the connector and remove from the ignition coils at the same time.

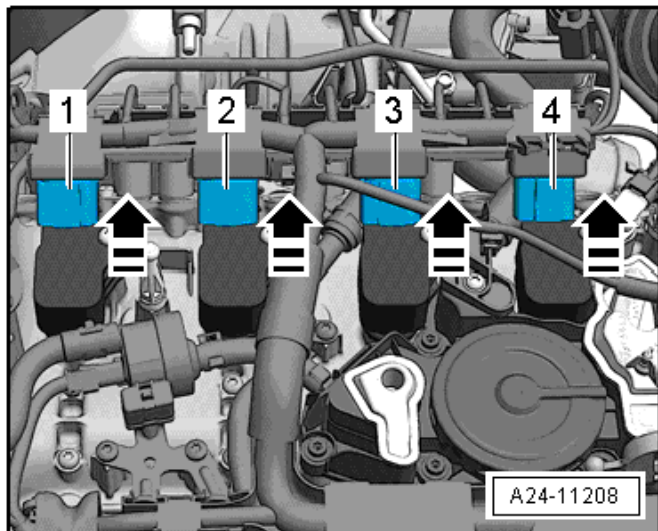

Technical Service Bulletin



Audi

- Disconnect the connector <arrows>
- Remove the ground wires from the top of each ignition coil.
- Move the wire harness out of the way.

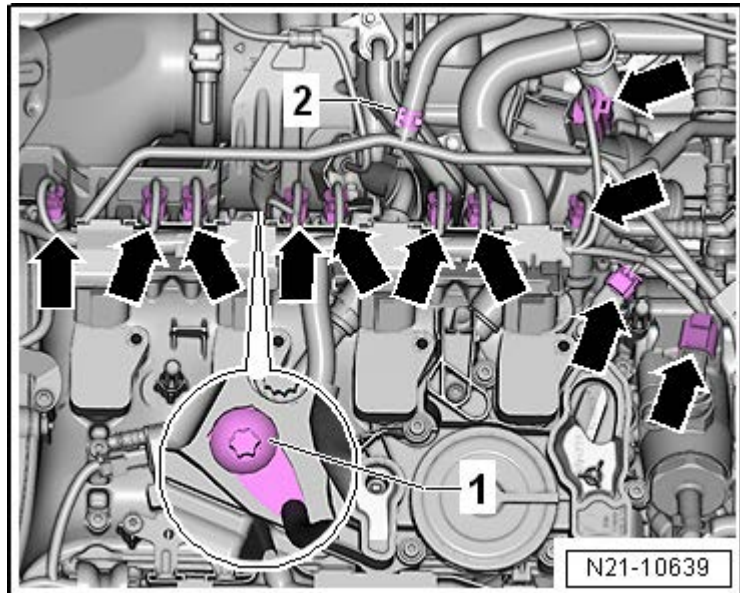

- Remove the bolts <1>,<2> and <3>.
- Remove clamp and hose at position <5>.
- Pivot the coolant pipe to the side.

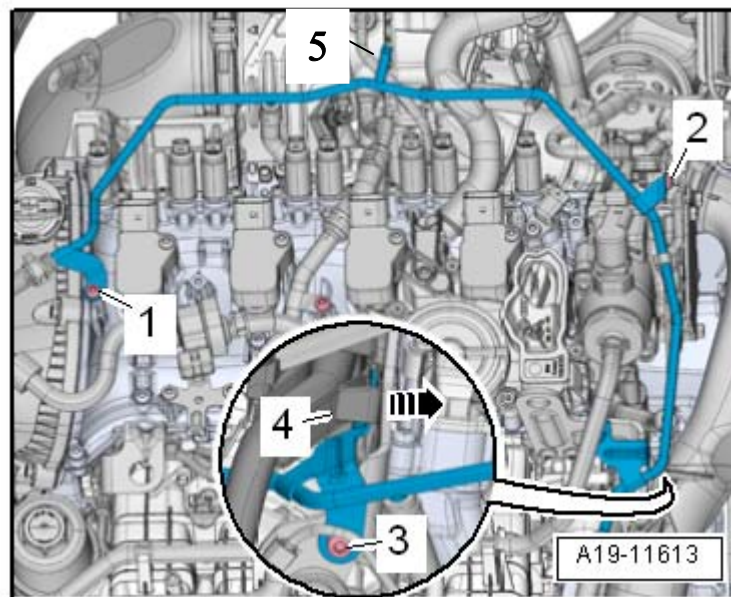



Audi

Technical Service Bulletin

- Remove the cam adjustment actuator 4 thru 8 by removing the bolts <arrows>



Note

Cam Adjustment Actuators seals may be reused.

- Remove the vacuum in the brake booster by pressing the brake pedal repeatedly.
- Remove the vacuum hose from the brake booster.

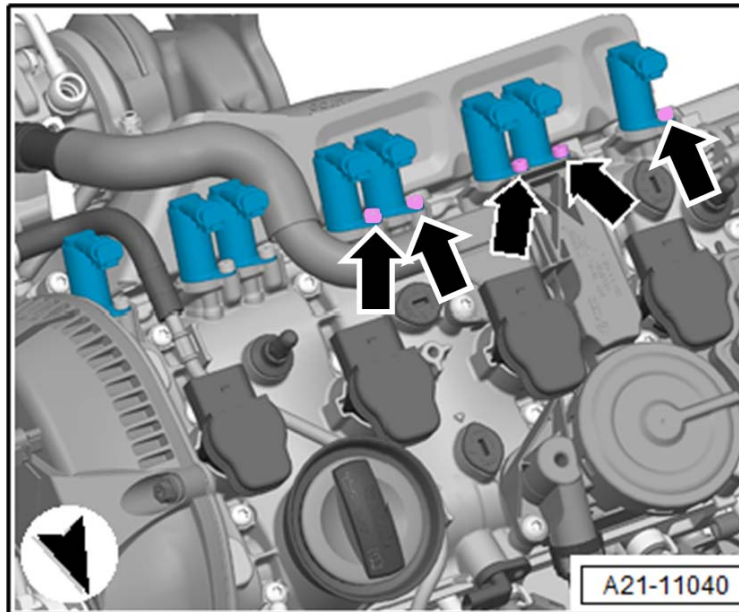

- Remove the bolts <arrows> and nut <1>.
- Remove the heat shield <2>.

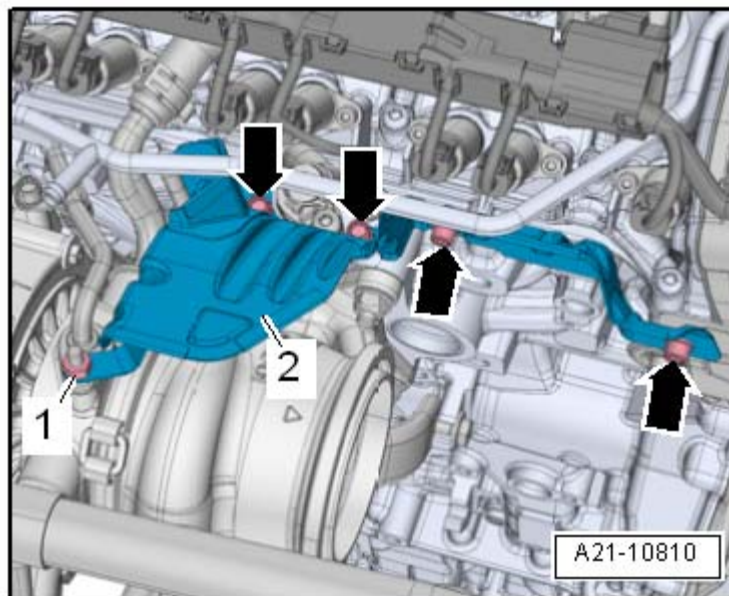

Technical Service Bulletin



- Loosen the clamp <1> and remove the air buide pipe.



Note

Ignore item <2>

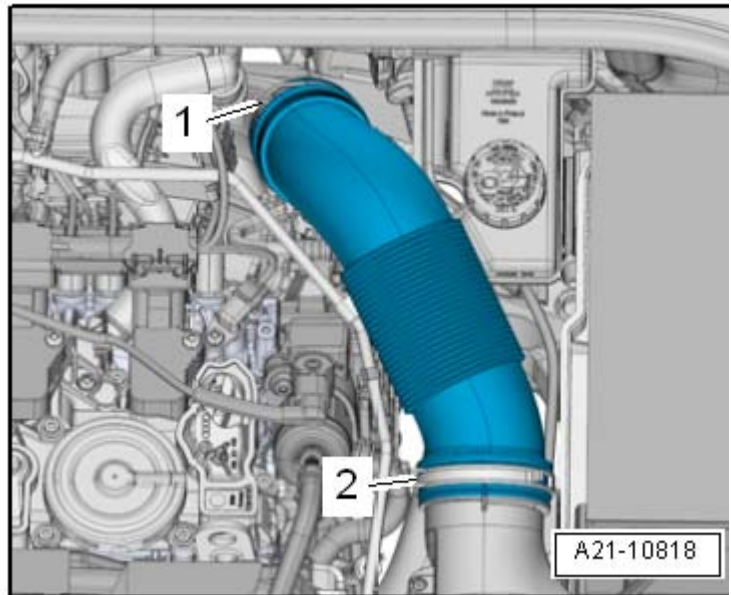

- Remove the bolt <1>.
- Loosen bolt <3>.

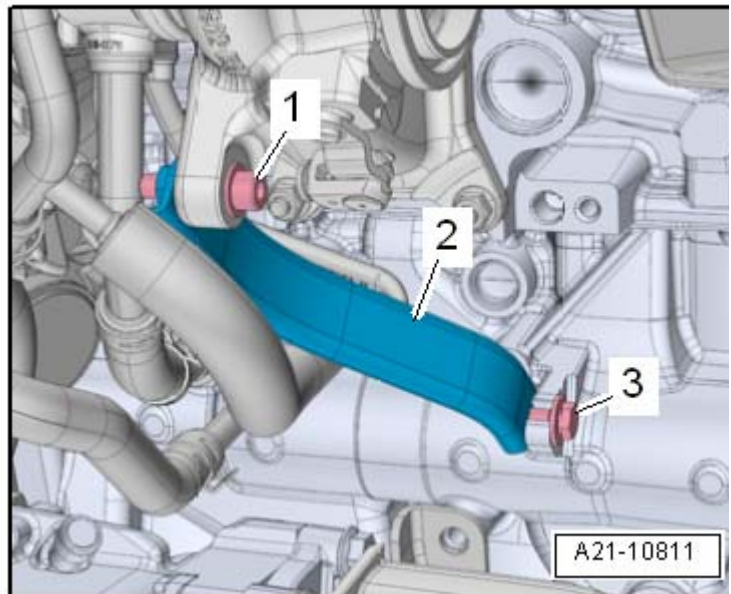

Technical Service Bulletin



- Disconnect the connectors <1>.
- Remove bolt <4> and move air pipe out of the way.

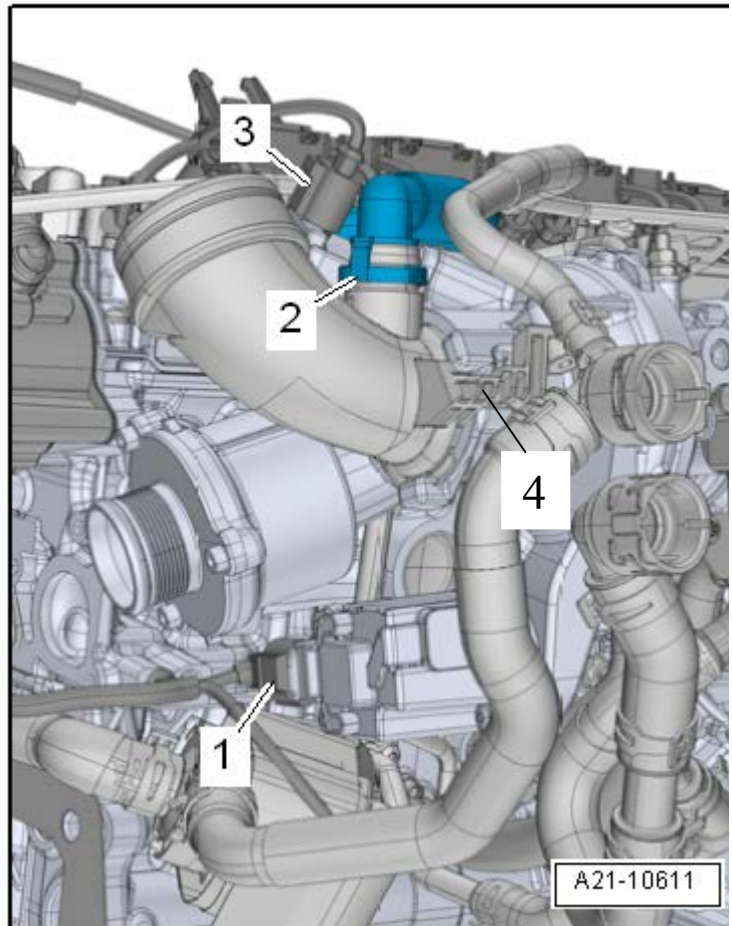

- Remove the bolts <1> and then remove the connections.
- Remove the bolts <2> and <3>, then remove the oil supply and return line.
- Remove the bolts connecting the coolant supply and return line to the turbocharger.
- Open the hose clamp <arrow>.

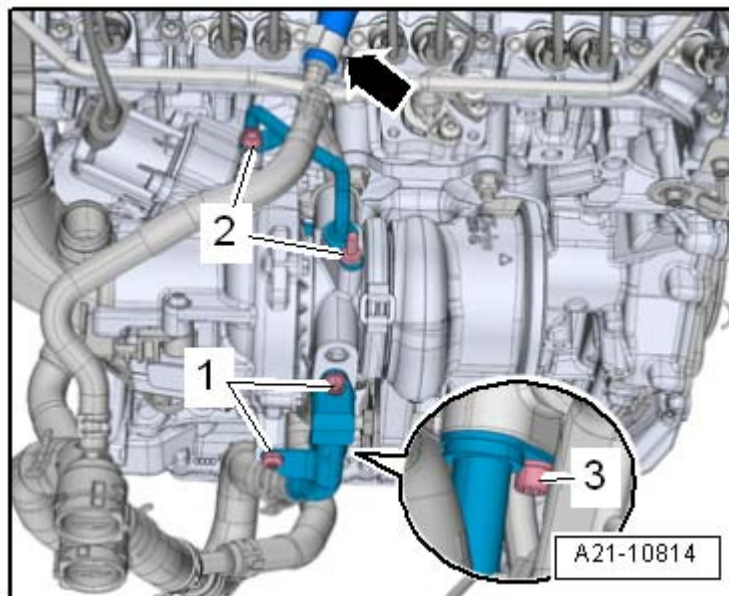

Technical Service Bulletin



- Remove the nuts <arrows>.
- Remove the turbocharger from the cylinder head and remove upwards.

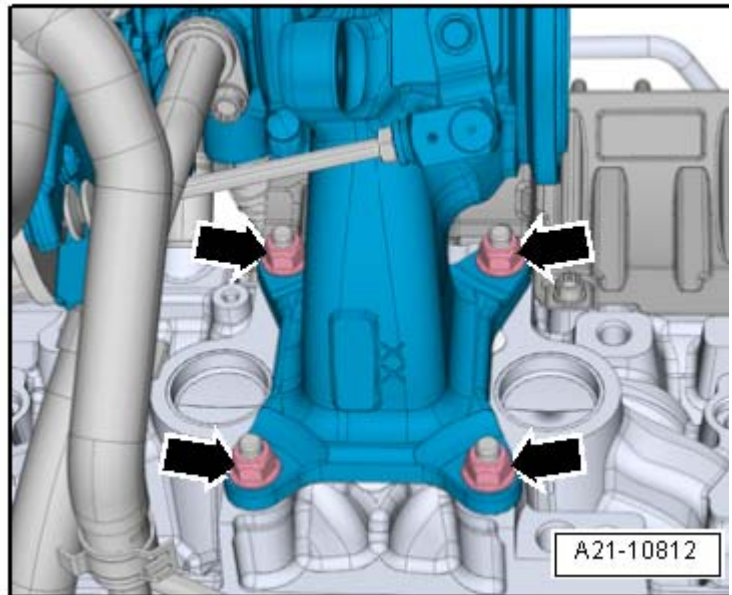

Installation

- Install in reverse order of removal and note the following.



Note

- Replace the seals, O-rings and the self-locking nuts from parts list below. All other parts do not need to be replaced.
- Coat the turbocharger stud bolts with hot bolt paste.
- Fill the turbocharger with engine oil at the oil supply line connection.
- Hose connections and charge air system hoses must be free of oil and grease before installing.
- Secure all hose connections with hose clamps of the same type as those equipped by the factory.
- Fill the coolant
- Check the oil level.



Note

After install the turbocharger, let the engine idle for approximately 1 minute without increasing engine speed. This ensures adequate oil supply to the turbocharger.

Technical Service Bulletin



Warranty

Update Time Requirements/ Reimbursement	To ensure prompt and proper payment, be sure to immediately enter the applicable reimbursement code listed below upon completion of the repair work. Claims will be paid only for vehicles that show the 21E7 code in the Elsa Campaign/Action Information screen on the day of repair.		
<p>21E7 Saga Claim Entry Procedure Check Elsa to determine whether Update 21E7 is open.</p> <p>Service No.: 21E7 Damage Code: 0099 Parts Manufacturer - Removed part: 002 Claim Type Sold vehicle = 7 10 Unsold vehicle = 7 90</p> <p>Saga Accounting Instructions</p>			
Criteria ID	Repair operation	Labor Operation Number	TU
8V	Turbocharger remove and reinstall	2130 1916	370
Criteria ID	Part Number	Part Description	Quantity
8V	06K 145 702 T	Turbocharger * (Select as Causal)	1.0
	06L 253 039	Gasket	1.0
	WHT 006 113	o-ring	1.0
	WHT 007 210	self-locking nut	4.0
	N 900 672 02	o-ring	1.0
	WHT 006 114	o-ring	2.0
	G 013A8J1G	Coolant Additive	Up to 1.5
	5Q0 253 115 B	Gasket	1.0
	5Q0 253 725 C	Clamp	1.0

Technical Service Bulletin



There is no reimbursement for vehicle wash or loaner vehicle.

If the vehicle is outside of the specified warranty period OR if customer refused repairs.

U.S. dealers: Submit the request through Audi Warranty Online under the Campaigns/Update option.

Canadian dealers: Fax the Repair Order to Warranty at (905) 428-4811 and provide VIN, applicable Service Number, Customer Information, Dealer Number and Date.

Additional Actions	Some of the affected vehicles may be involved in additional Actions. Please check your Elsa Campaign/Action Information screen so that any <i>additional required work can be done simultaneously.</i>
Verifying Vehicle Eligibility	To verify vehicle eligibility for this Update, <i>always</i> check the Elsa Campaign/Action Information screen. The Elsa system is the <i>only</i> binding inquiry and verification system; other systems are not valid and <i>may result in non-payment</i> of a claim.
Help for Claim Entry	For questions regarding claim entry, contact Audi Warranty.
Required Customer Notification	Inform your customer in writing by recording on the Repair Order any and all work that was conducted on the vehicle, including any and all updates completed under this Update.

Technical Service Bulletin



Required Parts and Tools

Part Number	Part Description	Quantity
06K 145 702 T	Turbocharger	1.0
06L 253 039	Gasket	1.0
WHT 006 113	o-ring	1.0
WHT 007 210	self-locking nut	4.0
N 900 672 02	o-ring	1.0
WHT 006 114	o-ring	2.0
G 013A8J1G	Coolant Additive	1.5 Up to
5Q0 253 115 B	Gasket	1.0
5Q0 253 725 C	Clamp	1.0

- Properly destroy and dispose of removed parts in accordance with all state and local requirements, unless otherwise indicated and/or requested through SAGA.
- If you have exhausted your allocated parts and you require additional parts for vehicles affected by this Update but have exceeded your Upper Order Limit, please submit your requests for additional parts via email to upperorderlimits@audi.com. Be sure to include the affected VINs with your order. Prior to submitting your request, ensure that each vehicle has the **21E7** code open in Elsa. Your order will be reviewed and processed accordingly.

Additional Information

All parts and service references provided in this Update are subject to change and/or removal. Always check Elsa for the most current version of this document.

Audi of America, Inc.



Date: August 01, 2014

To: Audi Dealer Principal, Service Manager, and Parts Manager

From: Audi Product Compliance

Subject: Upcoming Update 21E7
Turbocharger (NVLW)
2015 Model Year Audi A3

Dear Audi Dealer Principal, Service Manager, and Parts Manager:

This communication is to inform you of upcoming Update **21E7**.

What vehicles are affected?

There are 249 Audi vehicles affected in the U.S. by this Update.

Of the affected vehicles, the following are in dealer inventory:

New Vehicle Inventory: 16

CPO Inventory: 0

What is the issue?

On Audi A3 vehicles manufactured within a specific period the turbocharger may fail causing the MIL to illuminate.

What does the repair procedure involve?

The turbocharger will be replaced.

When will the Update be available?

This Update will be visible in Elsa and ServiceNet on or about August 5, 2014.

Please refer to the Elsa campaign/action screen for confirmation of whether the Update applies to each specific vehicle. Additionally, this Update is posted on Elsa and ServiceNet for additional information and complete repair instructions.

Consistent with general Audi corporate policy governing Updates, Audi is not notifying consumers. (Updates differ from recalls and service actions; consumers are notified in writing of recalls and service actions.) Each vehicle should be completed when it is in to the dealer for maintenance or any other service visit. Dealer stock vehicles **cannot, however, be delivered** to consumers until the Update is completed.

To identify any vehicles in your inventory that are affected by this Update, please run the "New and CPO Inventory Open Campaign/Action Listing" report from the AIM system.

Please ensure that every affected vehicle gets the update before delivery to consumers. Your effort is integral in reaching the highest quality expectations of Audi customers.

Thank you for your cooperation and assistance in this important matter.

Audi of America, Inc.
3800 Hamlin Road
Auburn Hills, MI 48326
+1 248 754 5000
www.audiusa.com