



SB-10056336-1366

TO: All Mazda Dealership General Managers, Service Managers, and Parts Managers
DATE: August 2014
SUBJECT: 2003-2004 Mazda6 and 2004 RX-8 Passenger Air Bag Safety Recall 7714F

Mazda Motor Corporation has decided that a defect which relates to motor vehicle safety exists in certain 2003-2004 Mazda6 vehicles produced from May 29, 2002 through March 4, 2004, and 2004 RX-8 vehicles produced from June 25, 2003 through June 30, 2003. This recall expands the vehicle population involved in the previous Safety Recall 6913D.

On certain 2003-2004 Mazda6 and 2004 RX-8 vehicles, the inflator propellant material for the passenger front air bag may have been improperly processed, which may cause increased combustion during air bag deployment. This could create excessive internal pressure within the inflator, and the body of the air bag module could rupture and injure the vehicle occupant(s).

On all subject vehicles, dealers are to replace the passenger side front air bag inflator. The original inflator must be returned to the manufacturer, as described in Attachment IV.

Owners of affected vehicles will be notified by first class mail beginning August 21, 2014 and informed that this repair will be available after September 15, 2014. Appointments are critical to minimize customer inconvenience. Mazda is requesting owners to make appointments for this repair, which allows time for dealers to order the correct air bag inflator using the customer's VIN.

PARTS INFORMATION

A new web page to order parts for this recall will be available in MXConnect during the first week of September. Detailed instructions regarding the parts ordering process will be sent to dealers at that time. A complete VIN is needed to process the order.

Description	Part Number	Quantity	Model
Passenger Front Air Bag Inflator	GJYA-57-K80	1	Mazda6
	FEY1-57-K80A	1	RX-8

This package contains important information about Safety Recall 7714F:

Attachment I	Parts and Service Information
Attachment II	Repair Procedure
Attachment III	Owner Notification Letter
Attachment IV	Air Bag Inflator Return Instructions

The National Traffic and Motor Vehicle Safety Act prohibits the delivery of any subject vehicle without performing the necessary repair for defects or failures. Failure to perform applicable recalls before delivery can result in extensive dealer fines and penalties from the Federal Government. Therefore, you must complete this recall for all affected vehicles in your inventory prior to delivery.

To help you effectively perform this recall, Mazda has developed the following resources:

1. The attached service information, repair procedure, parts information, and air bag inflator return instructions are available on eMDCS and MS3 (Mazda Service Support System) websites via MXConnect.
2. For technical assistance, contact the Technical Assistance Hotline at (888) 832-8477, Option 3 for English speaking Hotline Specialist, Option 4 for Spanish speaking Hotline Specialist.
3. For parts questions, contact the Corporate Dealer Assistance Group at (877) 727-6626, Option 2.
4. For warranty questions, contact the Warranty Hotline at (877) 727-6626, Option 3.
5. **After September 15**, we recommend using the Recall Reminder Report #JS30R165-1 and Recall Reminder Labels available in Web Reporting to encourage customers to come in for the recall (with recall reminder postcards). Dealers may use such owner information for the sole purpose of conducting and performing this recall, and for no other purpose. **Using it for marketing activities is strictly prohibited and could subject your dealership to serious fines.** The information in the report is protected by state privacy and other applicable laws regarding disclosure of personal and/or confidential, restricted or blocked information. It is the dealer's responsibility to protect the confidentiality of owner records and prevent the release of information to other parties.

Please make certain the appropriate personnel in your dealership are aware of these resources and are familiar with the details of this recall before responding to customer inquiries.

We apologize for any inconvenience this recall may cause you and your customers. Your understanding and support in carrying out this campaign is greatly appreciated.

Sincerely,



Satoshi Takahashi
Director, Technical Services Division
Mazda North American Operations

CONDITION OF CONCERN

On certain 2003-2004 Mazda6 and 2004 RX-8 vehicles, the inflator propellant material for the passenger front air bag may have been improperly processed, which may cause increased combustion during air bag deployment. This could create excessive internal pressure within the inflator, and the body of the air bag module could rupture and injure the vehicle occupant(s).

Dealers are to replace the inflator in the passenger front air bag on all subject vehicles, at no charge to the vehicle owner. Refer to Attachment II for repair instructions.

MANDATORY AIR BAG INFLATOR RETURN

Upon receiving the replacement air bag inflator (P/Ns GJYA-57-K80 or FEY1-57-K80A), the original air bag inflator should be returned the same day the repair is performed. Do not wait for Warranty Claim Entry or Warranty Parts Requests.

Failure to return the original inflator will result in a Warranty Claim Debit.

Detailed air bag inflator return instructions are provided in Attachment IV and can also be found on MS3 and the Dealer Assistance Group website.

SUBJECT VEHICLES

Model	VIN Ranges	Build Date Range
2003-2004 Mazda6	1YV HP**** 35 M00030 – M52493 1YV HP**** 45 N00002 – N52970 1YV FP**** 35 M00214 – M56933 1YV FP**** 45 N00001 – N53045	May 29, 2002 through March 4, 2004
2004 RX-8	JM1 FE17** 40 106447 – 107142	June 25, 2003 through June 30, 2003

The asterisk symbol “*” can be any letter or number.

OWNER NOTIFICATION

Mazda will notify U.S. owners by first class mail beginning August 21, 2014.

PARTS INFORMATION

Description	Part Number	Quantity	Notes
Passenger Front Air Bag Inflator	GJYA-57-K80	1	Mazda6
	FEY1-57-K80A	1	RX-8
Campaign Label	9999-95-065A-06	1=50 labels	Obtain in MStore (no charge)

PARTS ORDERING

A new web page to order parts for this recall will be available in MXConnect during the first week of September. Detailed instructions regarding the parts ordering process will be sent to dealers at that time. A complete VIN is needed to process the order.

WARRANTY CLAIM PROCESSING INFORMATION

	Replacement of Passenger Front Air Bag Inflator	
	Mazda6	RX-8
Warranty Type	R	R
Process Number	AE015A	AE015A
Symptom Code	99	99
Damage Code	99	99
Causal Part Number	GJYA-57-K80	FEY1-57-K80A
Quantity	1	1
Labor Operation Number	XXK8XXRX	XXK8XXRX
Labor Hours	0.4 H	0.4 H

RENTAL CAR INFORMATION

Mazda will authorize rental and service loaner vehicles on a limited basis. We are requesting dealer understanding and partnership regarding rental and loaner vehicle utilization. Please make every effort to utilize alternative transportation solutions in place of rental use. Rental is covered if customer has no alternative means of transportation.

Rental Car Warranty Claim Information

Please submit rentals on a separate claim problem number as follows:

	Rental Agency Vehicle	Dealer Loaner Car Fleet Vehicle
Warranty Type Code	A	A
Symptom Code	99	99
Damage Code	99	99
Part Number Main Cause	5555-77-14FR	5555-77-14FL
Part Quantity	0	Number of days loaner car was used Mazda pays \$35.00/day
Labor Operation Code	MM024XRX	MM024XRX
Labor Hours	0.0	0.0
Sublet – Rental Car		
Sublet Invoice Number	Number from Rental Invoice or Dealer Purchase Order	
Sublet Type Code	Enter “Z9” (other)	
Sublet Amount	Up to \$30.00 per day for the number of days customer had rental car	
Sublet Text	Number of days rental car was supplied to customer	

Rental expenses exceeding the two-day limit will require prior DSM Authorization, as outlined in the Mazda Rental Car Reimbursement Program policy.

VERIFY THE VEHICLE NEEDS THE RECALL

1. Verify the vehicle is within the following ranges:

Model	VIN Ranges	Build Date Range
2003-2004 Mazda6	1YV HP**** 35 M00030 – M52493 1YV HP**** 45 N00002 – N52970 1YV FP**** 35 M00214 – M56933 1YV FP**** 45 N00001 – N53045	May 29, 2002 through March 4, 2004
2004 RX-8	JM1 FE17** 40 106447 – 107142	June 25, 2003 through June 30, 2003

The asterisk symbol “*” can be any letter or number.

If the vehicle is not within the above ranges, return it to the customer.

2. Perform a Warranty Vehicle Inquiry using your eMDCS System and inspect the vehicle for an Authorized Campaign Label RECALL 7714F attached to the vehicle’s hood or bulkhead.

eMDCS System – Warranty Vehicle Inquiry Results:

If eMDCS displays:	Campaign Label is:	Action to perform:
RECALL 7714F	Present	Contact the Warranty Hotline at (877) 727-6626, option 3, to update vehicle history.
	Not present	Proceed to “REPAIR PROCEDURE”.
RECALL 7714F CLOSED	Present	Return vehicle to inventory or customer.
	Not present	Complete a label and apply to vehicle's hood or bulkhead.
RECALL 7714F is not displayed	Does not apply	Recall does not apply to this vehicle. Return vehicle to inventory or customer.

REPAIR PROCEDURE

Please refer to Attachment II.

2003-2004 MAZDA6 AND 2004 RX-8 - PASSENGER AIR BAG SAFETY RECALL 7714F

A. VEHICLE INSPECTION PROCEDURE

1. Verify that the vehicle is within the following ranges:

Model	VIN Range	Build Date Range
2003-2004 Mazda6	1YV HP**** 35 M00030 – M52493	From May 29, 2002 through March 4, 2004
	1YV HP**** 45 N00002 – N52970	
	1YV FP**** 35 M00214 – M56933	
	1YV FP**** 45 N00001 – N53045	
2004 RX-8	JM1 FE17** 40 106447 – 107142	June 25, 2003 through June 30, 2003

- If the vehicle is within the above ranges, proceed to Step 2.
 - If the vehicle is not within the above ranges, return vehicle to the customer or inventory.
2. Perform a Warranty Vehicle Inquiry using your eMDCS System and inspect vehicle for Campaign Labels **Recall 7714F** attached to the vehicle's hood or bulkhead. Refer to eMDCS System - Warranty Vehicle Inquiry Results table below.

NOTE: Be sure to verify Recall number as the vehicle may have multiple Recall labels.

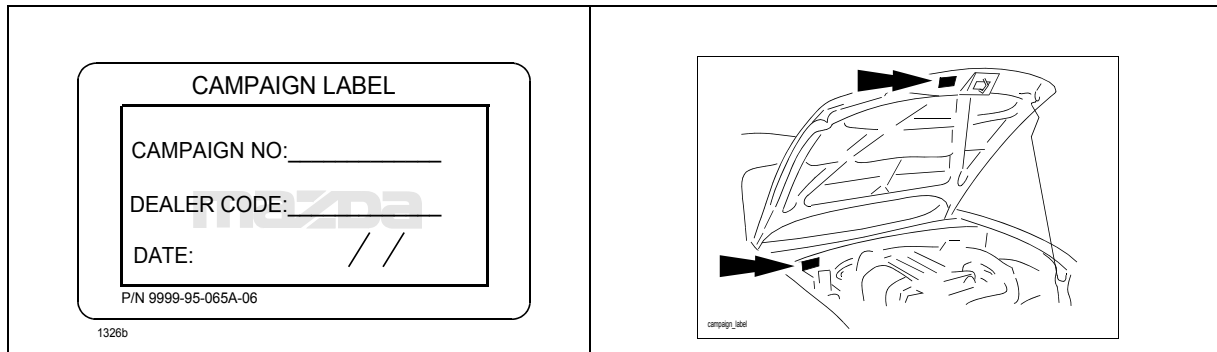

eMDCS System - Warranty Vehicle Inquiry Results:

If eMDCS displays:	Campaign Label is:	Action to perform:
RECALL 7714F OPEN	Present	Contact the Warranty Hotline at (877) 727-6626 option 3 to update vehicle history.
	Not present	Proceed to "B. REPAIR PROCEDURE".
RECALL 7714F CLOSED	Present	Return vehicle to inventory or customer.
	Not present	Proceed to "C. CAMPAIGN LABEL INSTALLATION".
RECALL 7714F is not displayed	Does not apply	Recall does not apply to this vehicle. Return vehicle to inventory or customer.

B. REPAIR PROCEDURE

2003-2004 Mazda6:

Passenger-Side Air Bag Inflator Replacement Procedure:

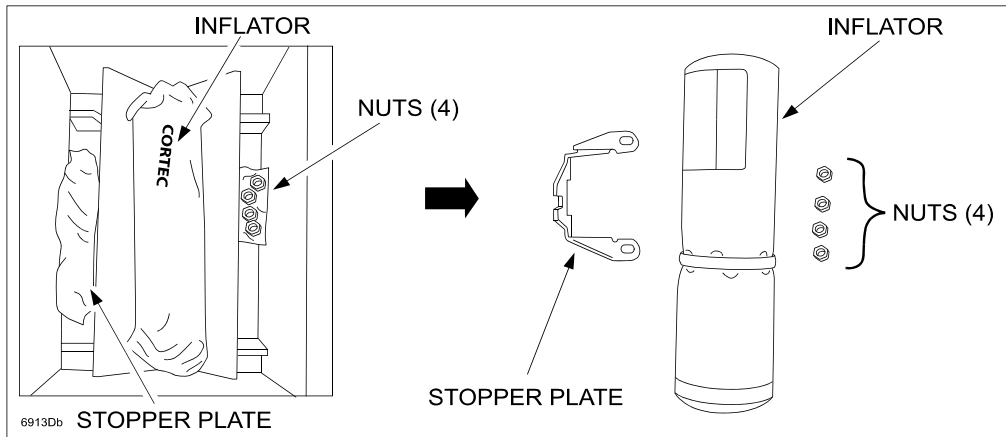

Outline:

1. Remove the inflator from the passenger-side air bag module, then replace it with a modified one.

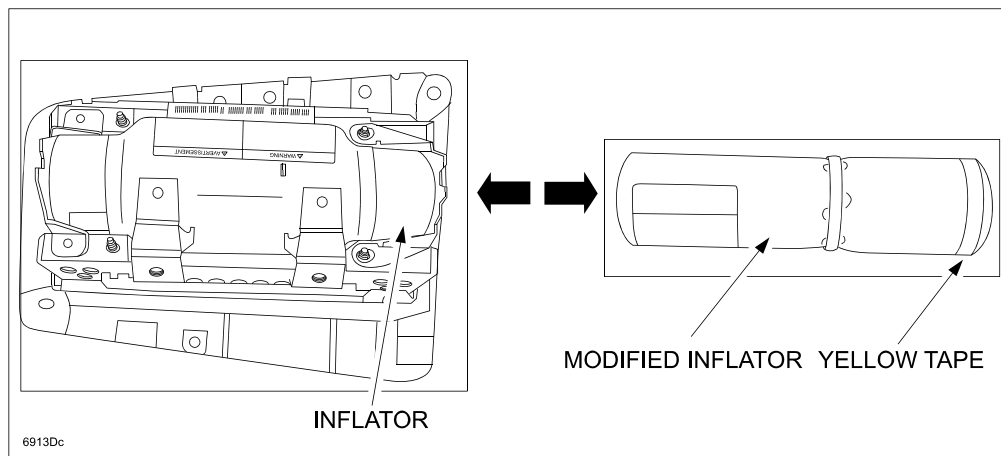

2. Pack and return the removed inflator as follows:

IMPORTANT: Be sure to follow the packing and shipping instructions provided in the carton and in Attachment IV, Air Bag Inflator Return Instructions.

CAUTION:

- Use the same carton which was used to deliver a new inflator. It is a specialized box that is internationally accepted for shipping an inflator.
- Pack the old inflator in the box exactly in the same manner as the new inflator was packed.

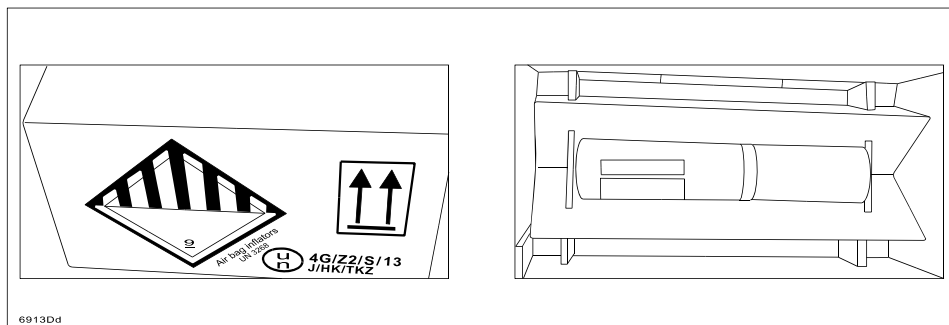

Air Bag Module Removal:

WARNING:

- Oil, grease, water, etc. on components may cause the air bag modules to fail to deploy in an accident, which may cause serious injury. Do not allow oil, grease, water, etc., on components.
- Inserting a screwdriver, etc., into the connector of an air bag module may damage the connector and cause the air bag module to deploy improperly, which may cause serious injury. Do not insert any foreign objects into the connector.
- Do not disassemble the vehicle, other than instructed here.
- Do not make an attempt to directly supply electrical power to the module and the inflator.
- Keep the module facing of the pad surface upwards at all times, except during replacement.
- Do not use the module and new inflator if they were dropped on the ground.
- Avoid module and inflator exposure to temperatures of 194 degrees F (90 degrees C) or more.

1. Turn the ignition switch to the LOCK position.
2. Record the customer's preset radio stations.
3. Disconnect the negative battery cable and wait for one (1) minute or more.
4. Remove the glove compartment.
 - a. Detach the string from the glove compartment.

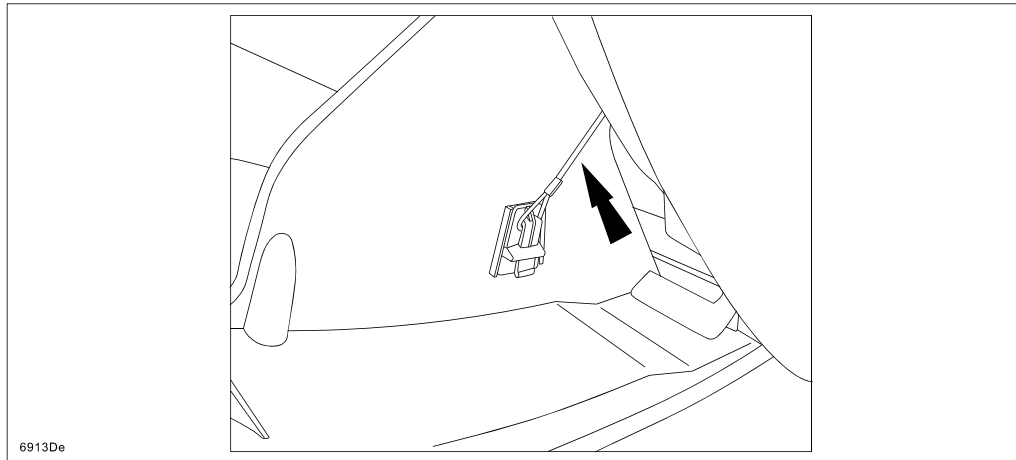

- b. Press the glove compartment stoppers inward.
- c. Lower the glove compartment downward and pull the clips to remove it.

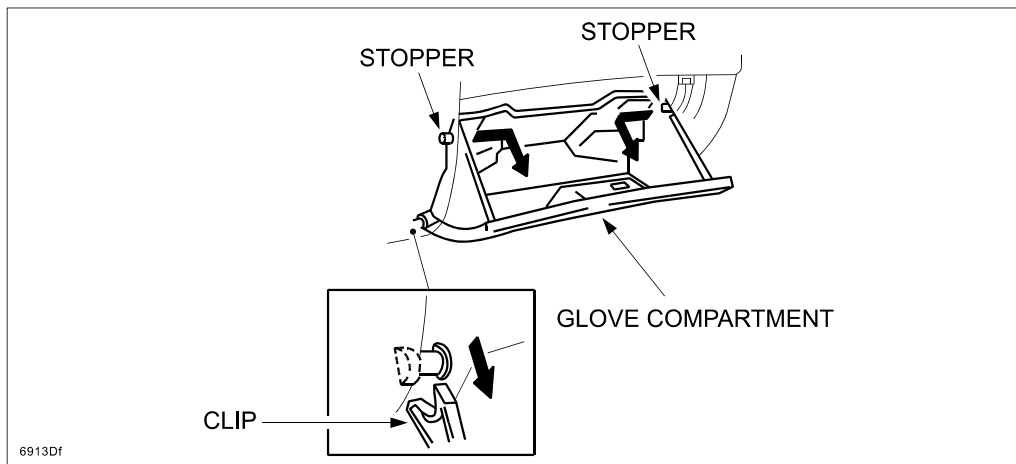

5. Remove the navigation unit (if equipped).
 - a. Remove the bolts.
 - b. Remove the navigation unit.

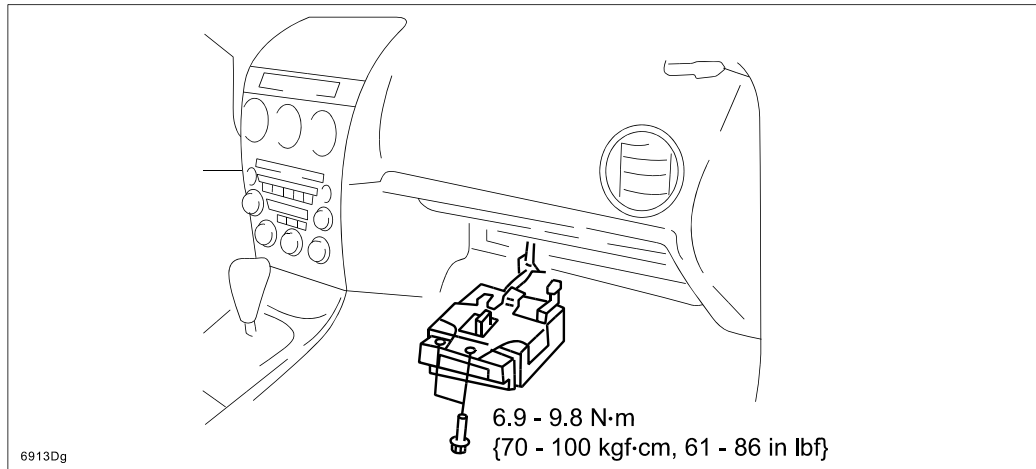

6. Remove the air bag module.
 - a. Using a flathead screwdriver, gently pry out the connector stopper plate.
 - b. Disconnect the connectors.

NOTE: Be careful not to pop off the stopper plate and lose it. It is not available as a separate part.

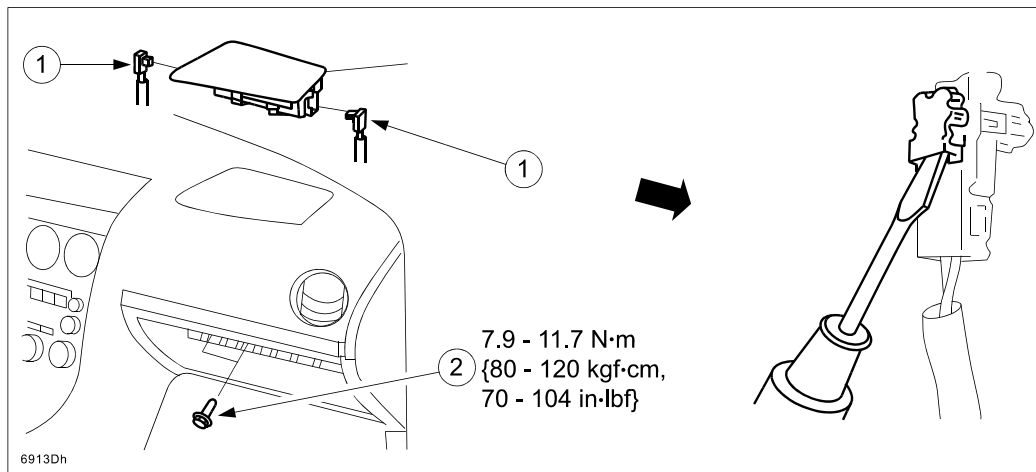

- c. Remove the bolts.
7. Lay a protective cloth on the work bench, then place the air bag module on it to avoid any damage or scratches to the surface.

Inflator Replacement:

1. Loosen four (4) nuts until the upper surface of the nuts are aligned with the top edge of the screw thread.
2. For easier inflator removal, depress the four (4) nuts and make a gap between the inflator and air bag module.

NOTE: Do not depress excessively as the module body may detach.

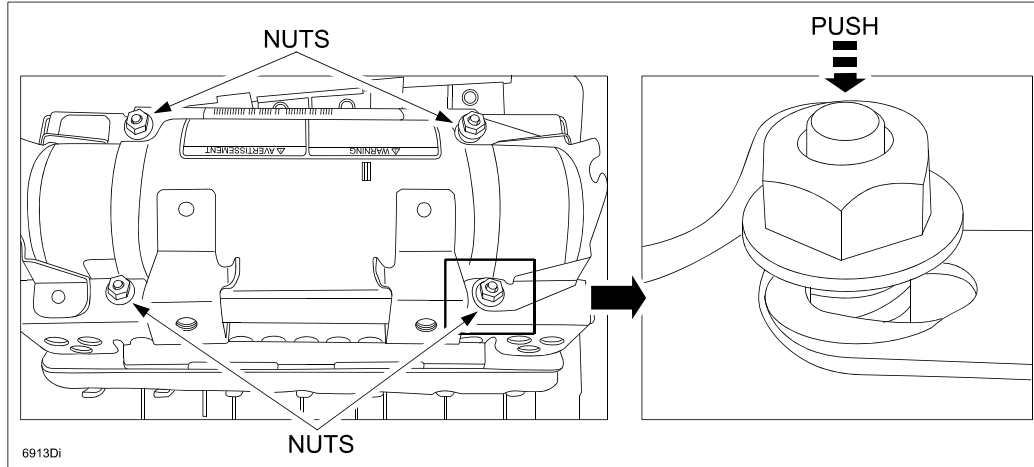

3. Remove the four (4) nuts, then remove the stopper plate from the air bag module.

NOTE: Discard all of the nuts and stopper plate.

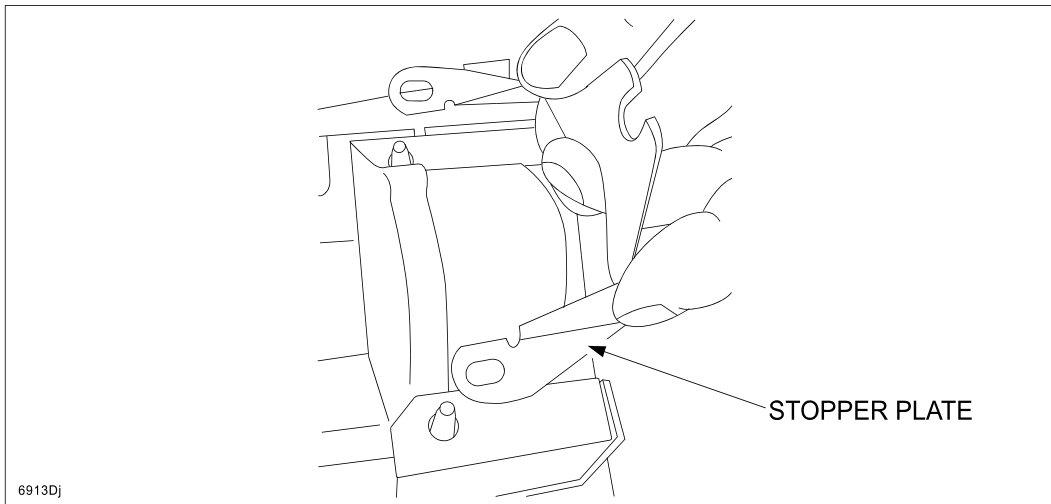

4. Push the inflator end with fingers, then remove it by sliding it in the direction shown below.

IMPORTANT: Return the removed inflator in the same carton in which the new part was received. Carefully follow the packing and shipping instructions included in the carton.

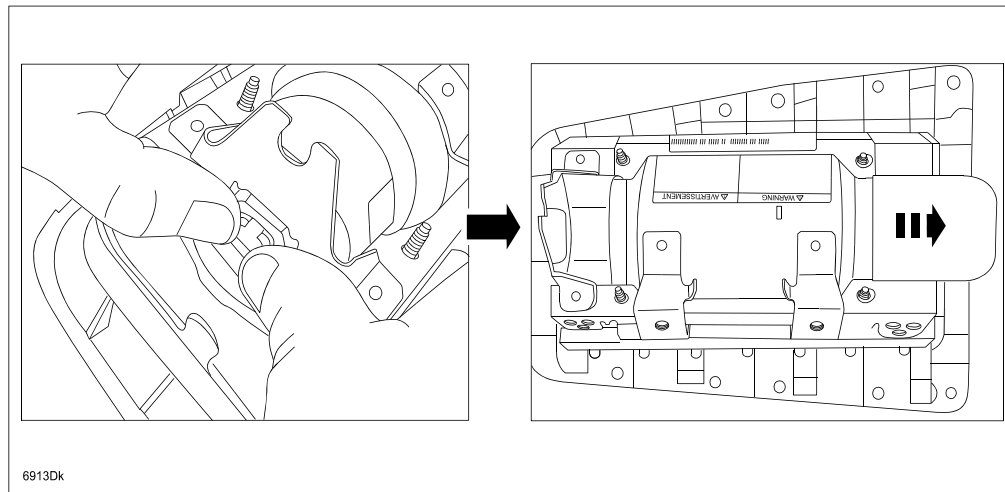

5. Insert the modified inflator from the opposite side of where the yellow identification tape is located.

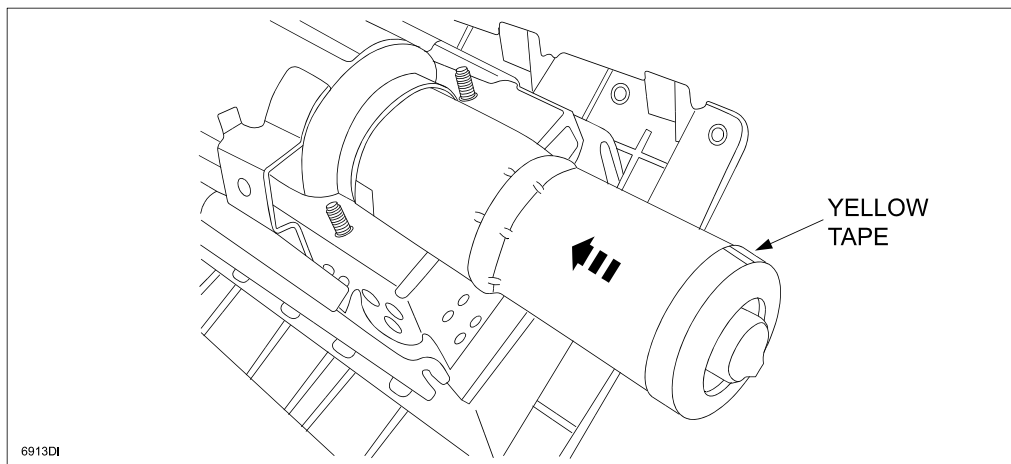

6. Insert the inflator up to the position where it touches the stopper, aligning the D-shape end of the inflator with the stopper opening.

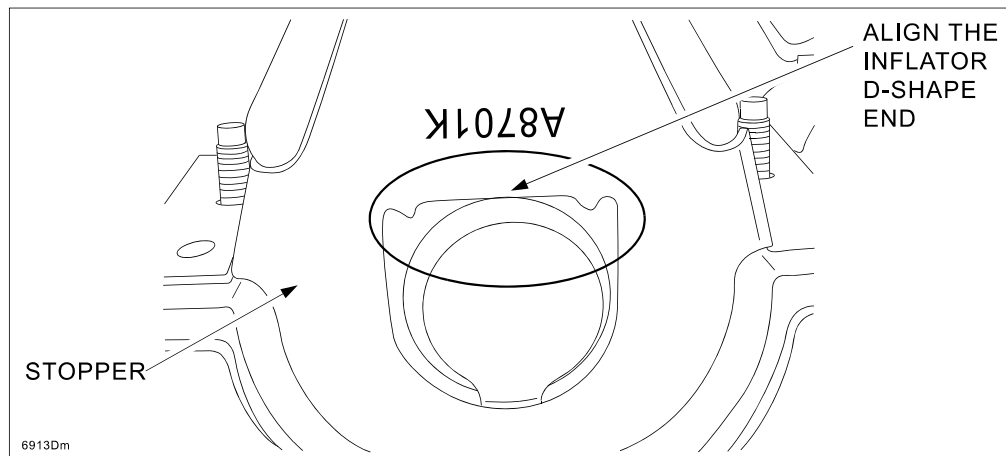

- Set the new stopper plate by gently pushing until it touches with the inflator side.

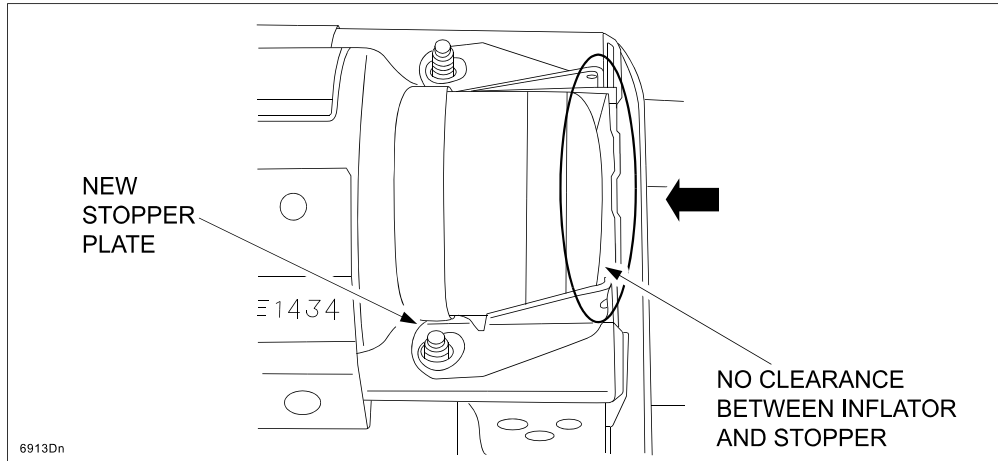

- Keeping the position above, hand tighten the four (4) new nuts.
- Tighten the four (4) new nuts to the specified torque in the order shown below (1, 2, 3, 4).
Tightening Torque: 35 +/- 1.8 in-lbf. {39.8 +/- 2.0 kgf-cm, 3.9 +/- 0.4 Nm}

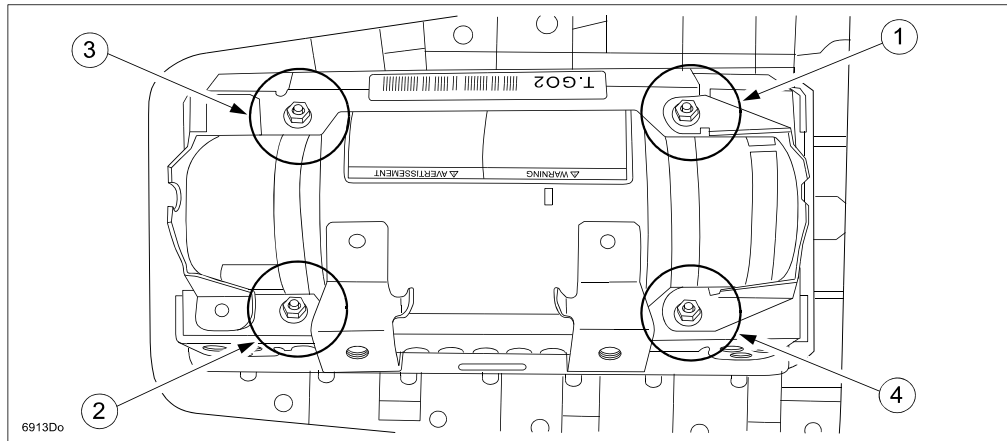

- Remove the seal from the end of the inflator on both sides.

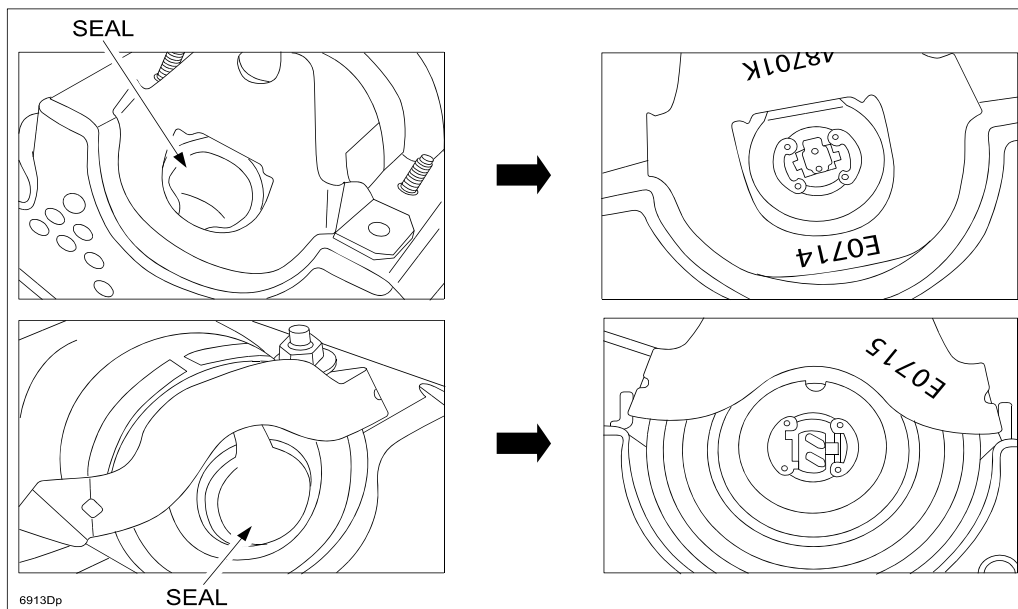

Air Bag Module Reinstallation:

1. Install the air bag module assembly.
2. Tighten the bolts to the specified torque.

Tightening Torque: 70 - 104 in-lbf. {80 - 120 kgf-cm, 7.9 - 11.7 Nm}

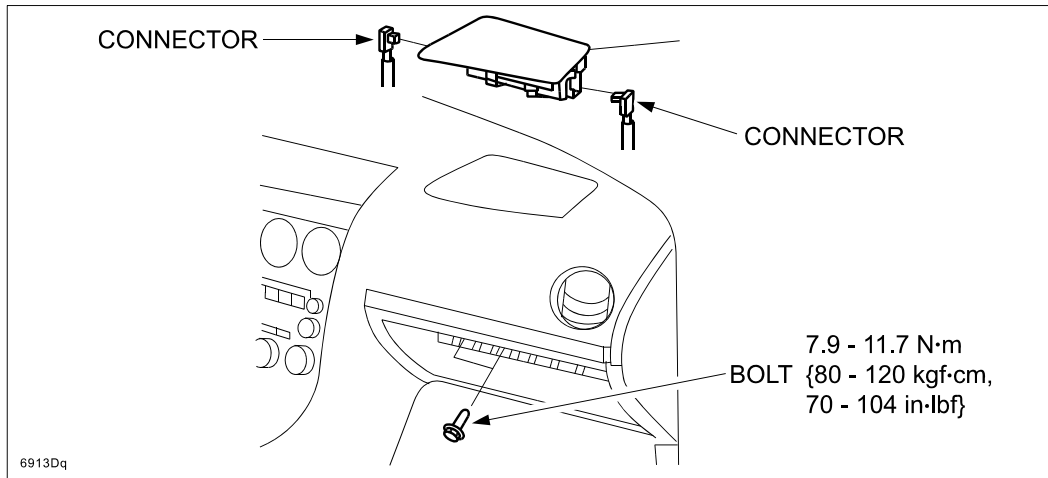

3. Re-connect the connectors to air bag module.
4. Securely lock the connectors by depressing the stoppers on the back of the connector.

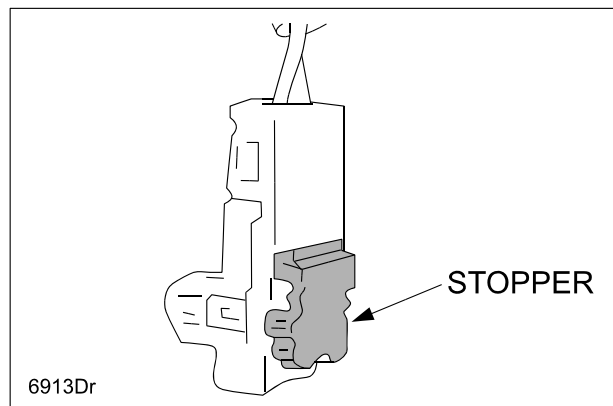

5. Reconnect the negative battery cable.
6. Turn the ignition switch to the ON position.
7. Verify that the air bag system warning light illuminates for approx. 6 sec., then goes out.

NOTE: If the air bag system warning light does not operate in the manner described above, there is a malfunction in the system. Inspect the system following the on-board diagnostic system procedure according to MS3 online or the Workshop Manual (section 08 Restraints).

8. Reinstall the navigation unit (if equipped).
9. Reinstall the glove box.
10. Re-enter the customer's preset radio stations.
11. Proceed to "C. CAMPAIGN LABEL INSTALLATION".

2004 RX-8:

Passenger-Side Air Bag Inflator Replacement Procedure:

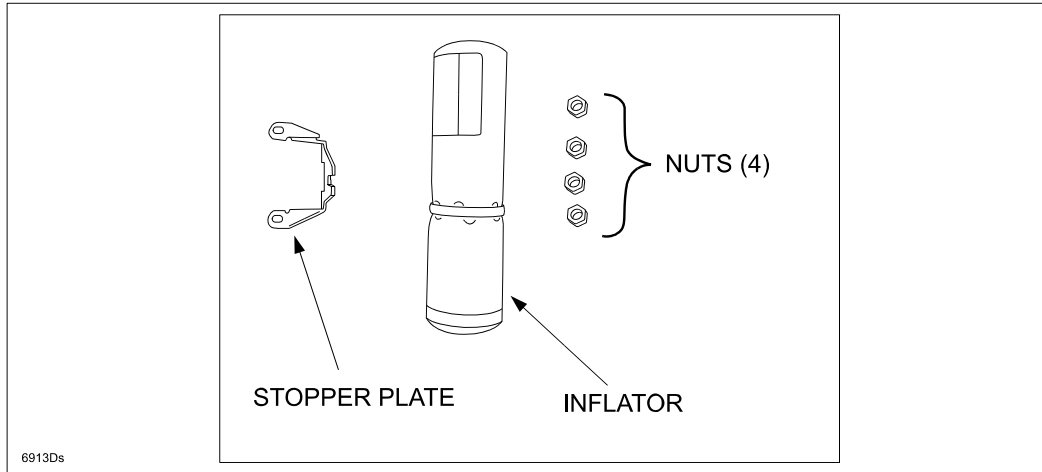

Outline:

1. Remove the inflator from the passenger-side air bag module, then replace it with a modified one.

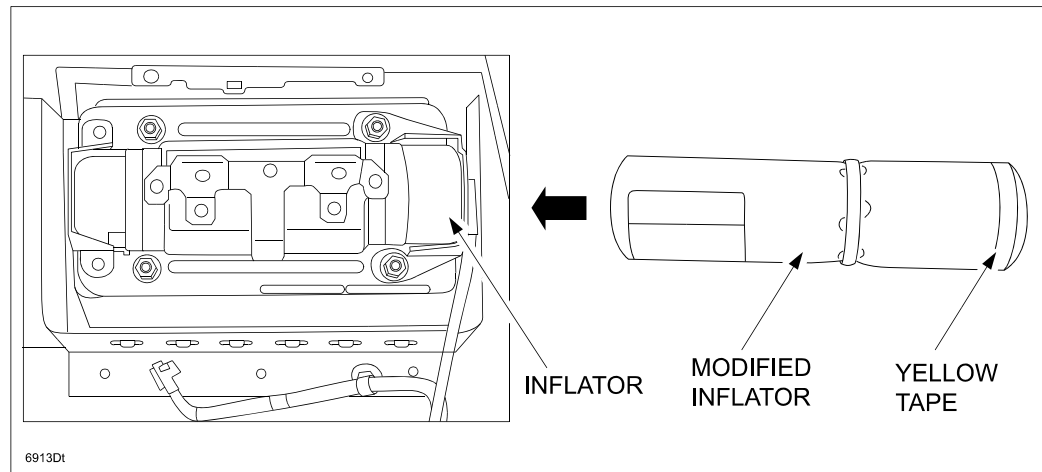

2. Pack and return the removed inflator as follows:

IMPORTANT: Be sure to follow the packing and shipping instructions provided in the carton and in Attachment IV, Air Bag Inflator Return Instructions.

CAUTION:

- Use the same carton which was used to deliver a new inflator. It is a specialized box that is internationally accepted for shipping an inflator.
- Pack the old inflator in the box exactly in the same manner as the new inflator was packed.

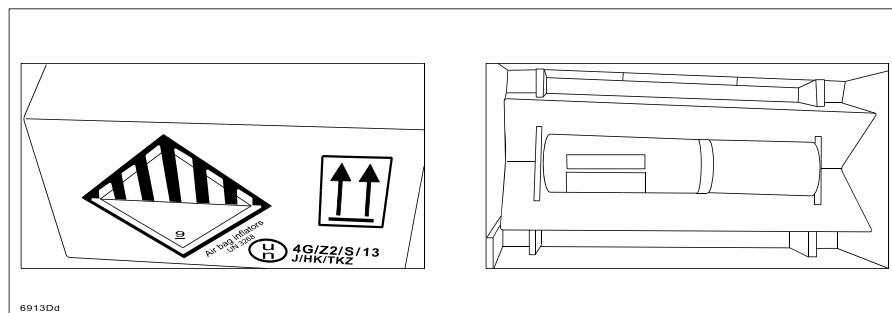

Air Bag Module Removal:**WARNING:**

- Oil, grease, water, etc. on components may cause the air bag modules to fail to deploy in an accident, which may cause serious injury. Do not allow oil, grease, water, etc., on components.
 - Inserting a screwdriver, etc., into the connector of an air bag module may damage the connector and cause the air bag module to deploy improperly, which may cause serious injury. Do not insert any foreign objects into the connector.
 - Do not disassemble the vehicle, other than instructed here.
 - Do not make an attempt to directly supply electrical power to the module and the inflator.
 - Keep the module facing of the pad surface upwards at all times, except during replacement.
 - Do not use the module and new inflator if they were dropped on the ground.
 - Avoid module and inflator exposure to temperatures of 194 degrees F (90 degrees C) or more.
1. Turn the ignition switch to the LOCK position.
 2. Record the customer's preset radio stations.
 3. Disconnect the negative battery cable and wait for one (1) minute or more.
 4. Remove the glove compartment.
 - a. Pull the stay damper in the direction shown below.
 - b. Detach the glove compartment from the stay damper.

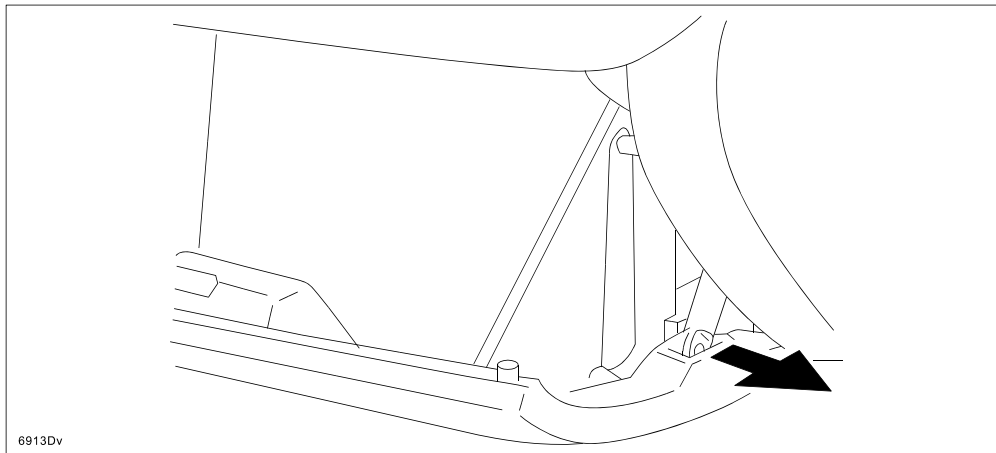

- c. Press the glove compartment stoppers inward.
- d. Lower the glove compartment downward.
- e. Detach the clips from the dashboard and remove the glove compartment.

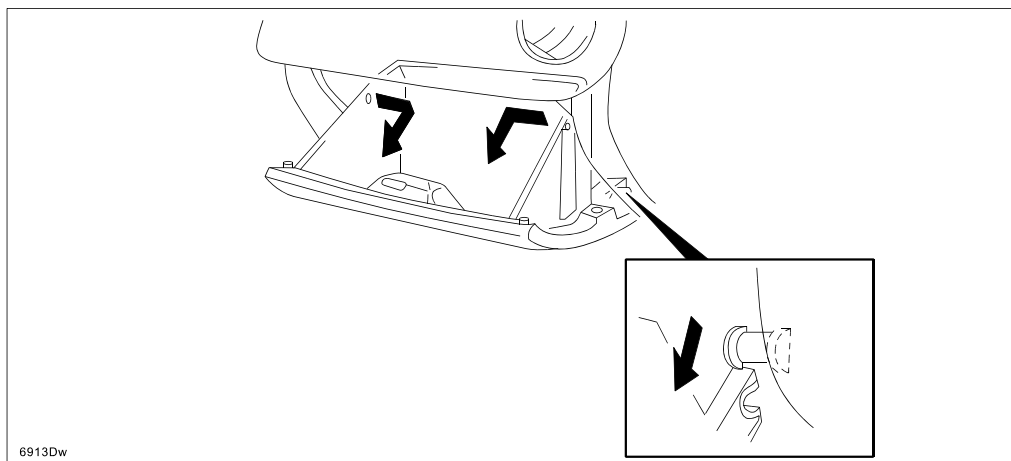

5. Remove the air bag module.
 - a. Remove the bolts.
 - b. Disconnect the connector.
 - c. Remove the air bag module.

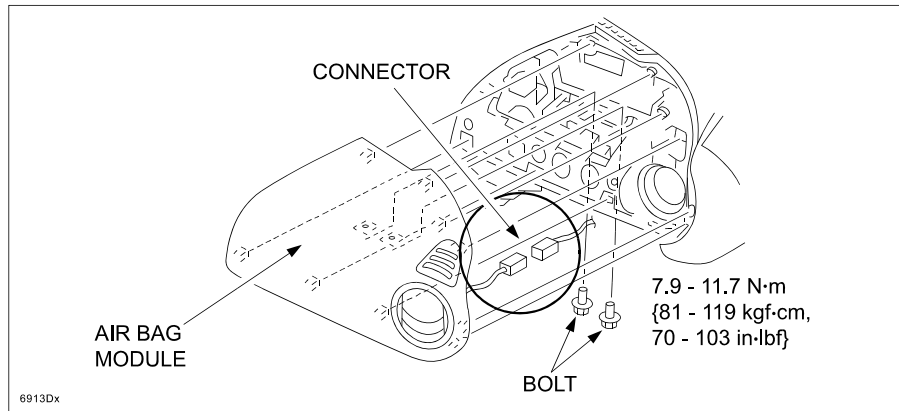

6. Lay a protective cloth on the work bench, then place the air bag module on it to avoid any damage or scratches to the surface.

Inflator Replacement:

1. Using a flathead screwdriver, pry out the connector stopper plate.

NOTE: Be careful not to pop off and lose the stopper plate. It is not available as a separate part.

2. Disconnect the connector.

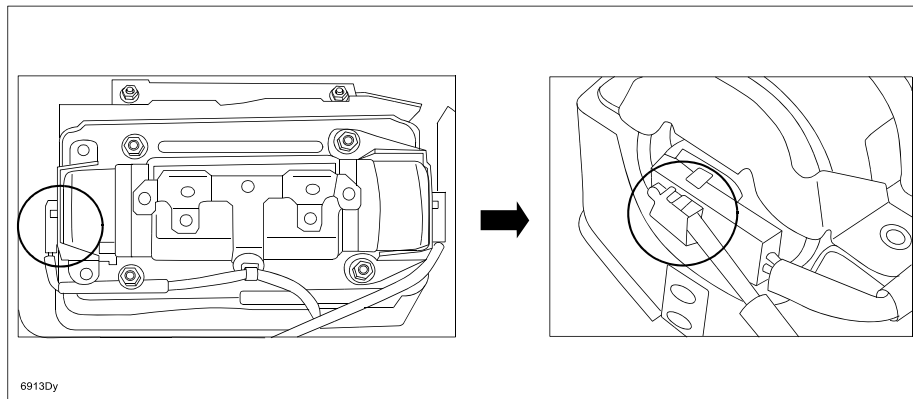

3. Loosen four (4) nuts until the upper surface of the nuts are aligned with the top edge of the screw thread.
4. For easier inflator removal, depress the four (4) nuts and make a gap between the inflator and air bag module.

NOTE: Do not depress excessively as the module body may detach.

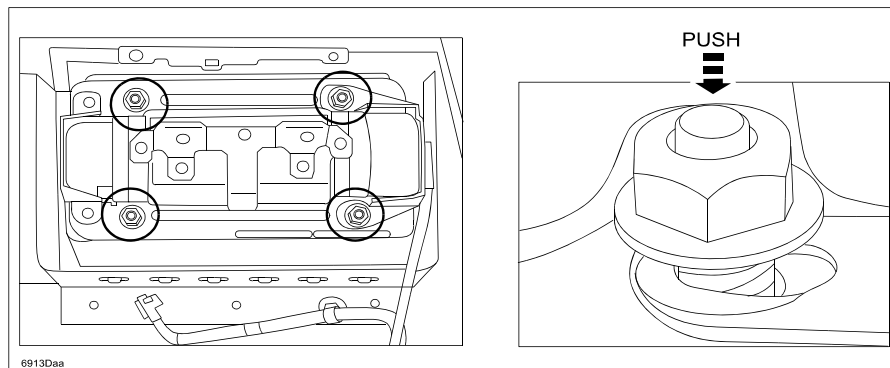

5. Remove the four (4) nuts, then remove the stopper plate from the air bag module.

NOTE: Discard all of the nuts and stopper plate.

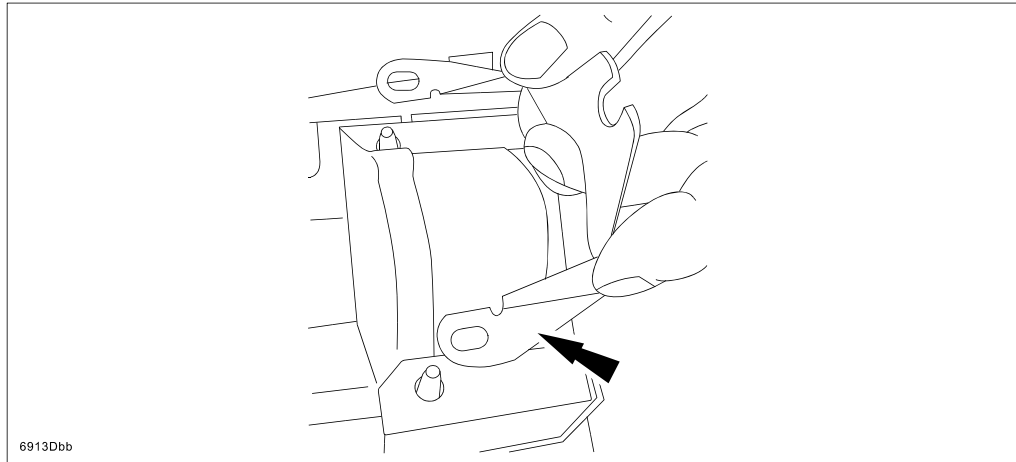

6. Push the inflator end with fingers, then remove it by sliding it in the direction shown below.

IMPORTANT: Return the removed inflator in the same carton in which the new part was received. Carefully follow the packing and shipping instructions included in the carton.

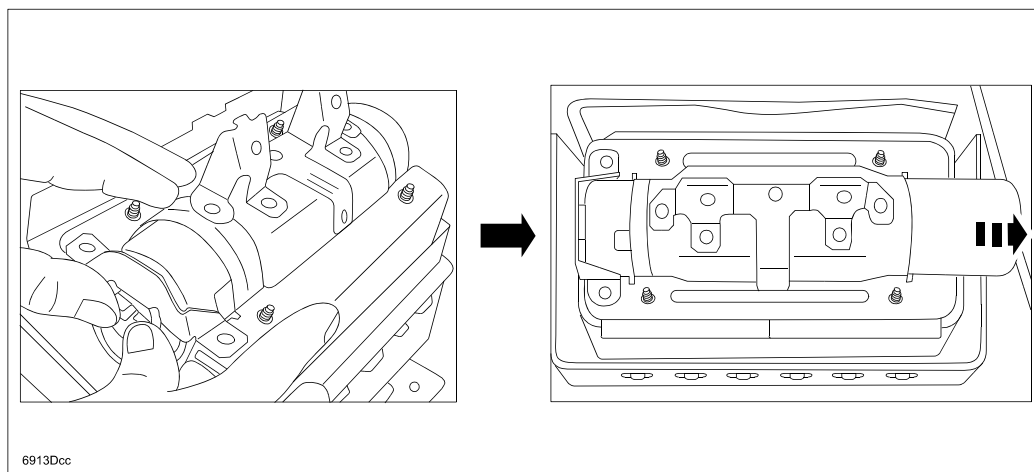

7. Insert the modified inflator from the opposite side of where the yellow identification tape is located.

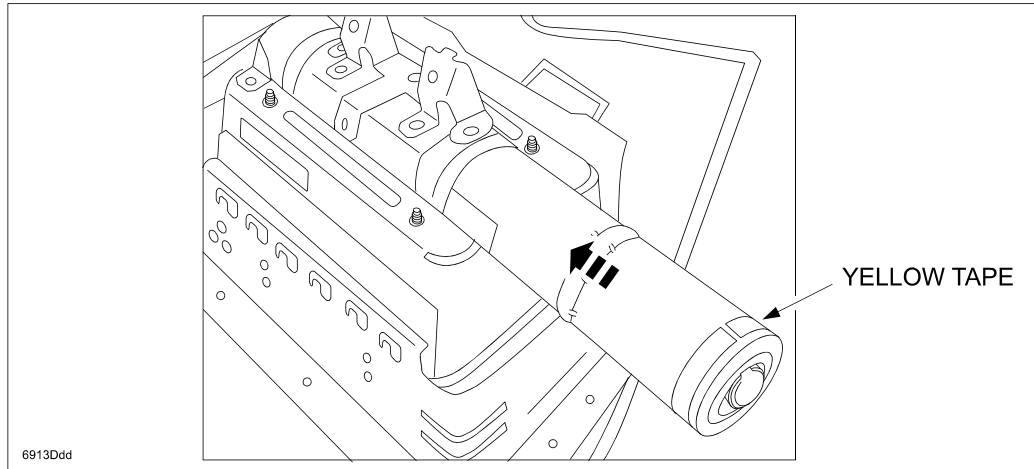

8. Insert the inflator up to the position where it touches the stopper, aligning the D-shape end of the inflator with the stopper opening.

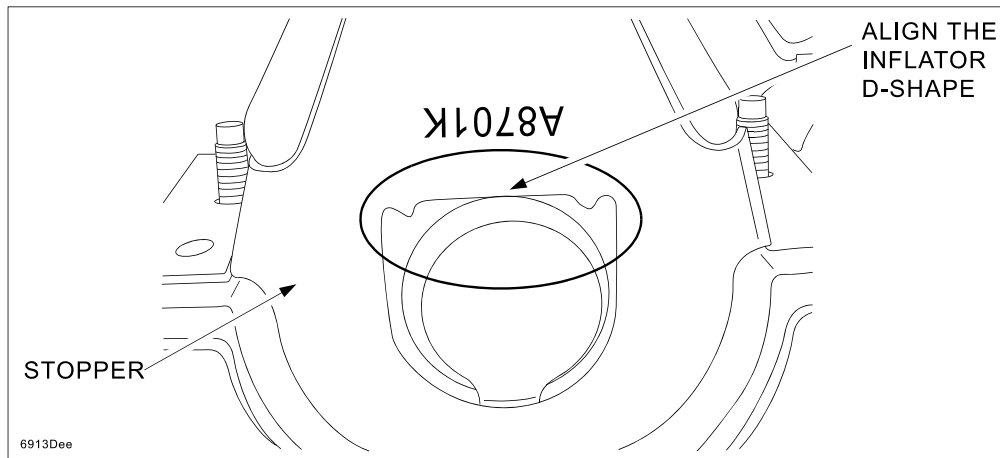

9. Set the new stopper plate by gently pushing until it touches with the inflator side.

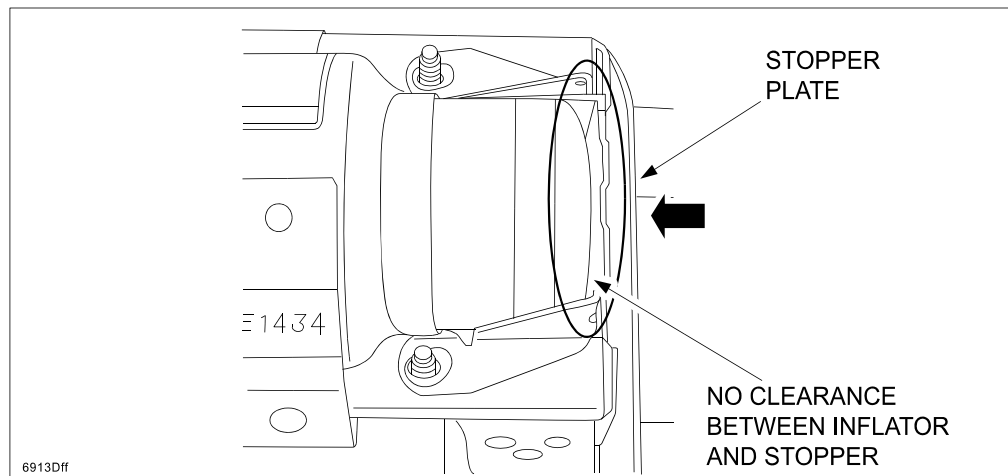

10. Keeping the position above, hand tighten the four (4) new nuts.
11. Tighten the four (4) new nuts to the specified torque in the order shown below (1, 2, 3, 4).
Tightening Torque: 35 +/- 1.8 in-lbf. {39.8 +/- 2.0 kgf-cm, 3.9 +/- 0.4 Nm}

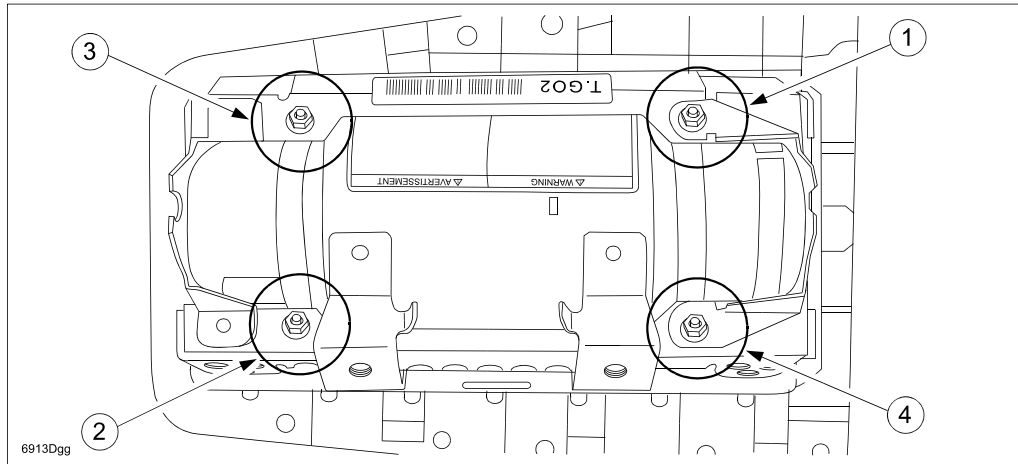

12. Remove the seal from the end of the inflator on both sides.

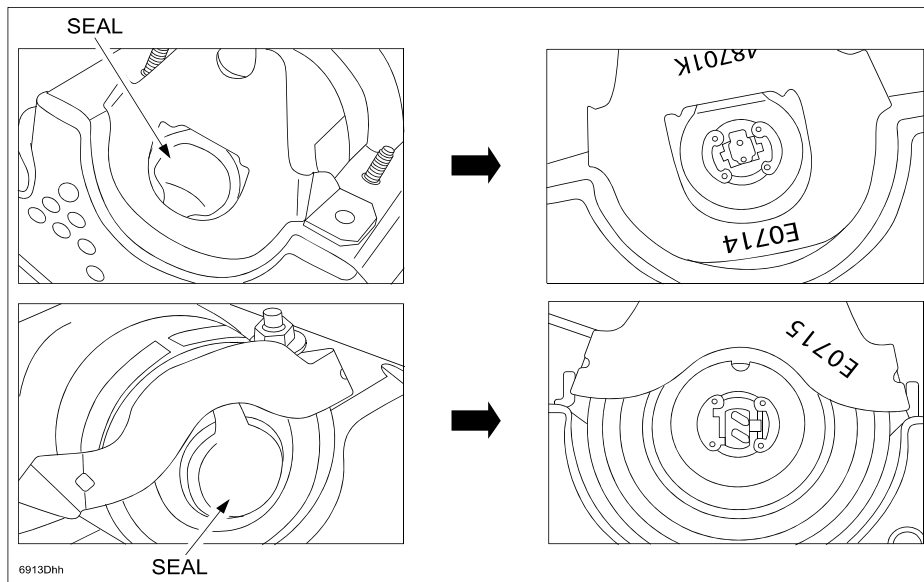

13. Install the new short harness to the inflator.
14. Securely lock the connectors by depressing the stoppers on the back of the connector.

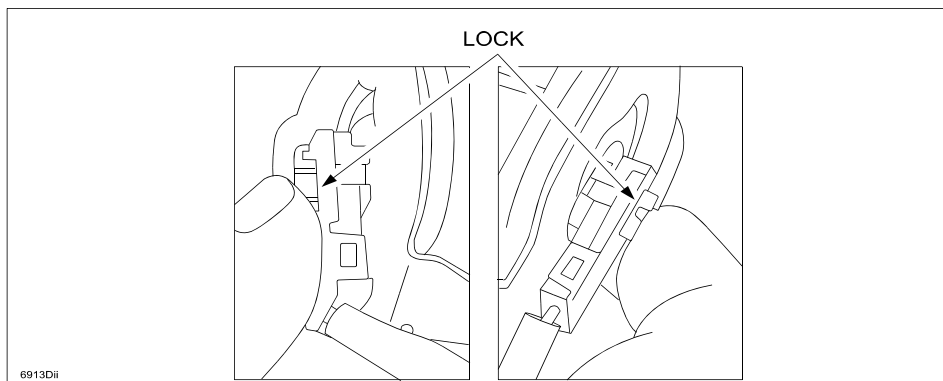

Air Bag Module Reinstallation:

1. Re-connect the connector, then install the air bag module.
2. Tighten the bolts to the specified torque.

Tightening Torque: 70 - 103 in-lbf. {81 - 119 kgf-cm, 7.9 - 11.7 Nm}

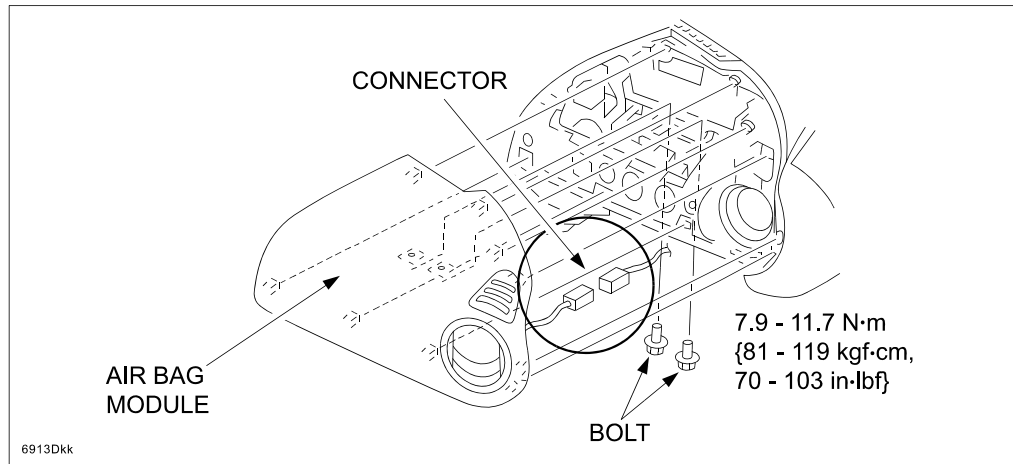

3. Reinstall the glove box.
4. Reconnect the negative battery cable.
5. Turn the ignition switch to the ON position.
6. Verify that the air bag system warning light illuminates for approx. 6 sec., then goes out.

NOTE: If the air bag system warning light does not operate in the manner described above, there is a malfunction in the system. Inspect the system following the on-board diagnostic system procedure according to MS3 online or the Workshop Manual (section 08 Restraints).

7. Re-enter the customer's preset radio stations.
8. Proceed to "C. CAMPAIGN LABEL INSTALLATION".

C. CAMPAIGN LABEL INSTALLATION

1. Fill out a blue "Campaign Label" (9999-95-065A-06) with Campaign No: "7714F", your dealer code, today's date.

CAMPAIGN LABEL	
CAMPAIGN NO:	_____
DEALER CODE:	_____
DATE:	/ /

P/N 9999-95-065A-06

1326b

2. Affix it to the hood or bulkhead as shown:

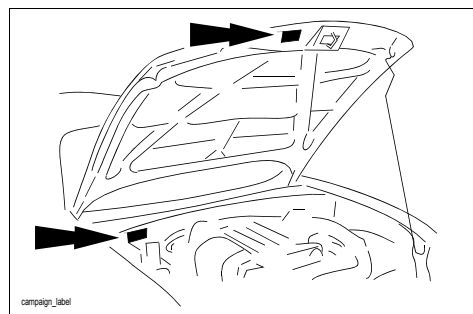

3. Return the vehicle to customer.



IMPORTANT SAFETY RECALL

**2003-2004 Mazda6 and 2004 RX-8
Front Passenger Air Bag - Safety Recall 7714F
NHTSA Campaign No. 14V-362**

August 2014

VIN _____

2003-2004 Mazda6 and 2004 RX-8 – Front Passenger Air Bag Safety Recall 7714F

Dear Mazda Owner:

This notice is sent to you in accordance with the requirements of the National Traffic and Motor Vehicle Safety Act.

Mazda Motor Corporation has decided that a defect which relates to motor vehicle safety exists in certain 2003-2004 Mazda6 vehicles produced from May 29, 2002 through March 4, 2004, and 2004 RX-8 vehicles produced from June 25, 2003 through June 30, 2003.

If you are a recipient of this notice, your vehicle is included in this recall.

What is the problem?

On certain 2003-2004 Mazda6 and 2004 RX-8 vehicles, the inflator propellant material for the front passenger air bag may have been improperly processed, which may cause increased combustion during air bag deployment. This could create excessive internal pressure within the inflator, and the body of the air bag module could rupture and injure the vehicle occupant(s).

What will Mazda do?

Your Mazda dealer will replace the front passenger air bag inflator, free of charge. This repair will be available at Mazda dealerships after September 15, 2014.

How long will it take?

The actual repair will take approximately half an hour to complete; however, it may take longer depending on the service workload at your Mazda dealership.

What should you do?

This repair will be available at Mazda dealerships after September 15, 2014. After that date, please contact any authorized Mazda dealer for an appointment to have this repair completed and provide your Vehicle Identification Number (VIN). This will allow your dealer to reserve the necessary air bag inflator for your vehicle. You do not need to bring this notice to the dealer, but it may assist in the check-in process.

Where is the closest Mazda dealer?

To locate your nearest Mazda dealer, visit our web site and use our “Locate a Dealer” feature at www.MazdaUSA.com.

Moved or no longer own this vehicle?

If you have moved or no longer own your Mazda vehicle, please complete the enclosed prepaid *Information Change Card* as soon as possible. This enables us to update our records and notify the current owner.

Federal law requires that any vehicle lessor receiving this recall notice must forward a copy of this notice to the lessee within ten days.

Still have questions?

If you have any questions regarding this campaign, please contact our Customer Experience Center at (800) 222-5500, option #6.

If Mazda or its dealers do not repair the defect free of charge and within a reasonable amount of time, you may notify the Administrator of the National Highway Traffic Safety Administration, 1200 New Jersey Ave., SE., Washington, DC 20590; or call the toll-free Vehicle Safety Hotline at 1-888-327-4236 (TTY: 1-800-424-9153); or go to <http://www.safercar.gov>.

We actively work to improve our products and search for solutions to improve your ownership experience. We sincerely apologize for any inconvenience this recall may cause you.

Sincerely,

Mazda North American Operations

PASSENGER AIR BAG INFLATOR PACKING & SHIPPING INSTRUCTIONS

48 State FedEx Ground Shipment Preparation

Instructions for mandatory return of original passenger air bag inflators for Mazda Safety Recall 7714F and Special Service Program SSP96.

Dealers in **Alaska, Hawaii, Puerto Rico, and Canada** **CANNOT** follow these shipping instructions. These dealers **MUST** contact the following Takata USA representative directly for shipping instructions: Miguel Prigadaa – Tel #: 210-250-5079 or Email: MLGTakataRestraints_International@menloworldwide.com.

CAUTION: Do not deploy the inflator. Return the inflator promptly after completing the repair.

1. Use the carton the new inflator was shipped in. Place the undeployed air bag inflator in the “cradle” of the box insert. **Do not include any other hardware that may rattle, causing rejection of your shipment.**



2. Close the top box flap, per box instructions use 2 inch clear packing tape and firmly apply a minimum of 2 inches tape on front flap extending a minimum of 2 inches on bottom side of box.
3. Complete and/or affix the provided FedEx Ground paperwork; PRP address label, OP-900PRP, and the adhesive document pouch, which were provided with the new inflator.
 - **OP-900PRP Hazardous Materials Certification form**
 - a) Separate the bottom four labels and place them in the zip lock pouch. Remove the pouch backing and firmly place on bottom side of box.
 - b) Fill in Shipper Name, Address and Chemtrek Contract Number (CCN) in 3 locations: the Box, FedEx, and Customer Copy. **The Chemtrek Contract Number (CCN) assigned to your dealership is available on MS3 with Recall 7714F and SSP96 documents.**
 - c) Date the FedEx and Customer Copy (forms are already pre-signed).
 - d) Peel off the Box Copy and firmly apply to the front side of the box flap.
 - e) On the FedEx and Customer copy, complete Tracking ID box by listing the 15 digit tracking ID found beneath the large bar code or peel off the SHIPPER RECEIPT and RECEIPT tabs found at top of the PRP Shipping Label and apply to the Tracking ID box.
 - f) Keep Customer Copy for dealer records and retain for a minimum of 2 years.
 - g) Give the FedEx Copy to the FedEx Ground driver.
 - **FedEx Ground PRP Shipping Label**
 - a) Fill in Shipper Name & Address at upper section of label (RA# is not required)
 - b) Peel off the label backing and affix to top of box to left of the Class 9 label. Use the scribe marks on the box as a guide so the PRP label does not touch any portion of the Class 9 label or its border.
 - c) When shipment is ready, call for FedEx Ground pick up using number listed for business locations (888-777-6040), or if you receive regular pickups, give the package to your FedEx Ground driver.
- Remove or black out any **old** shipping labels or barcodes (not hazard marks).
- Do not cover any portion of the Class 9 label, shipping name, UN number and UN box specifications.
- Prior to shipment, ensure all steps have been properly completed. All packages must be prepared in accordance with all DOT and FedEx Ground requirements. Incomplete or missing information will result in return to sender.

Return Procedure – Lower 48 States Only

Top of Inflator Shipping Box and Form



FEDEX GROUND PRP SHIPPING LABEL

CLASS 9 HAZARD LABEL

PROPER SHIPPING NAME AND ID NUMBER

UN SPECIFICATION MARKING

BOX COPY OF OP-900PRP FORM

FEDEX COPY OF OP-900PRP FORM

BOTTOM LABELS OF OP-900PRP FORM

CUSTOMER COPY OF OP-900PRP FORM

Bottom of Inflator Shipping Box



ADHESIVE POUCH CONTAINING ALL FOUR (4) BOTTOM LABELS FROM OP-900PRP FORM

STRIP OF CLEAR PACKING TAPE (enhanced in this photo)