



Mack Trucks, Inc.
Greensboro, NC USA

	Date	Group	No.	Release	Page
This Field Service Bulletin replaces bulletin FSB 293-024 dated 3.2014.	7.2014	293	026	01	1(3)

SB-10056267-7943

EGR Differential Pressure Sensor
MP10 US2007, MP10 US2010

FSB 293-026, Exhaust Gas Recirculation (EGR) Differential Pressure Sensor

(July 2014)

On MACK vehicles equipped with a MACK MP10 engine built between January 1, 2007 and January 1, 2013 that require the replacement of the EGR Venturi tube or an EGR differential pressure sensor, it will be necessary to replace them with a kit to update the system to the current levels.

Note: It is **NOT** necessary to replace the entire engine harness when a new type sensor is being installed.

Note: Once a vehicle has been updated with the new style EGR venturi tube and differential pressure sensor, future repairs of these components should be performed individually and not with the update kit.

Refer to the appropriate service bulletin in Function Group 29 for service procedures.

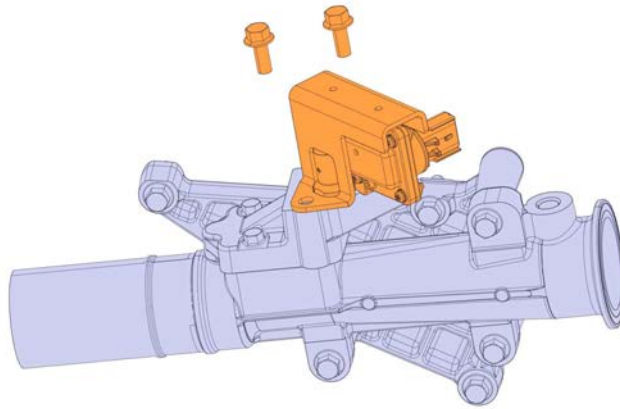

W2088348

Old Style Differential Pressure Sensor

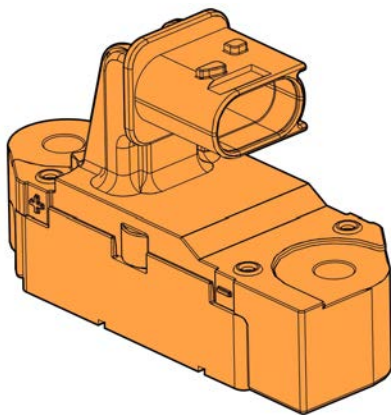

W2079416

New Style Differential Pressure Sensor

Required Parts

EGR Differential Pressure Sensor Kit	
Description (Application)	Kit Part Number
MP10	22069631

Kit Includes

Description	Quantity
Sensor	1
Harness	1
Venturi	1
Wrap	1
Screw Sensor	2
Hose Kit	1
O-Ring	1