



Classification:

EM14-002

Reference:

ITB14-031

COPYRIGHT© NISSAN NORTH AMERICA, INC.

Date:

July 15, 2014

2014 QX60 HYBRID; WHINE/WHIRRING NOISE FROM SUPERCHARGER AT IDLE

APPLIED VEHICLE: 2014 QX60 Hybrid (L50)**APPLIED ENGINE:** QR25DER

IF YOU CONFIRM

A loud whine or whirring noise is heard from the supercharger at idle.

NOTE: Superchargers can characteristically make a whine or a whirring noise when the throttle is opened quickly or when the vehicle is under a load, and is normal.

And/or

An intermittent growl or roar is present from the supercharger at any RPM:

- That only occurs until the engine has reached operating temperature
- And subsides after approximately 5 minutes

ACTION

Replace the supercharger with the procedure in this bulletin.

NOTE: This procedure will allow the supercharger to be removed without removing the driveline from the vehicle.

IMPORTANT: The purpose of "ACTION" (above) is to give you a quick idea of the work you will be performing. You **MUST** closely follow the entire Service Procedure as it contains information that is essential to successfully completing the repair.

Infiniti Bulletins are intended for use by qualified technicians, not 'do-it-yourselfers'. Qualified technicians are properly trained individuals who have the equipment, tools, safety instruction, and know-how to do a job properly and safely. **NOTE:** If you believe that a described condition may apply to a particular vehicle, **DO NOT** assume that it does. See your Infiniti dealer to determine if this applies to your vehicle.

SERVICE PROCEDURE

WARNING: This service procedure will be near high voltage components and is to be performed by certified HEV technicians ONLY.

1. Place the vehicle on a lift.
2. Write down the radio settings.

| Presets | 1 | 2 | 3 | 4 | 5 | 6 |
|---------|--------|---|---------|---|-----------------|---|
| AM | | | | | | |
| FM 1 | | | | | | |
| FM 2 | | | | | | |
| XM 1 | | | | | | |
| XM 2 | | | | | | |
| XM 3 | | | | | | |
| Bass | Treble | | Balance | | Speed Sen. Vol. | |

3. Turn the ignition OFF.
5. Lift the hood and remove the HYBRID 12V battery cover.
6. Disconnect the negative battery cable.

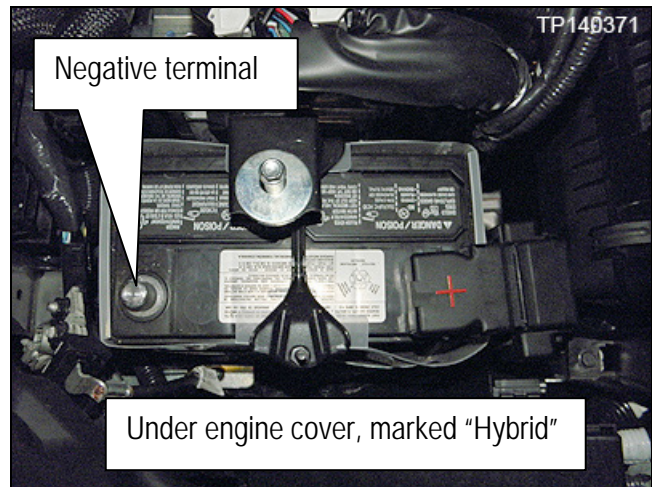

Figure 1

4. Disconnect the HEV Service Plug located in the rear cargo area under the rear floor trim.

WARNING:

- A service plug is installed on the high-voltage battery in order to securely shut off the high-voltage circuit during inspection and servicing of high-voltage components.
- When the service plug cover is opened, the service plug can be removed.
- Be sure to use insulated protective gear when removing and installing the service plug.



Figure 2

7. Remove both of the Cowl Top Side Trim Covers.



Figure 3

8. Remove both of the wiper arms (Figure 4).

9. Remove nine clips from the Cowl Top (Figure 4).

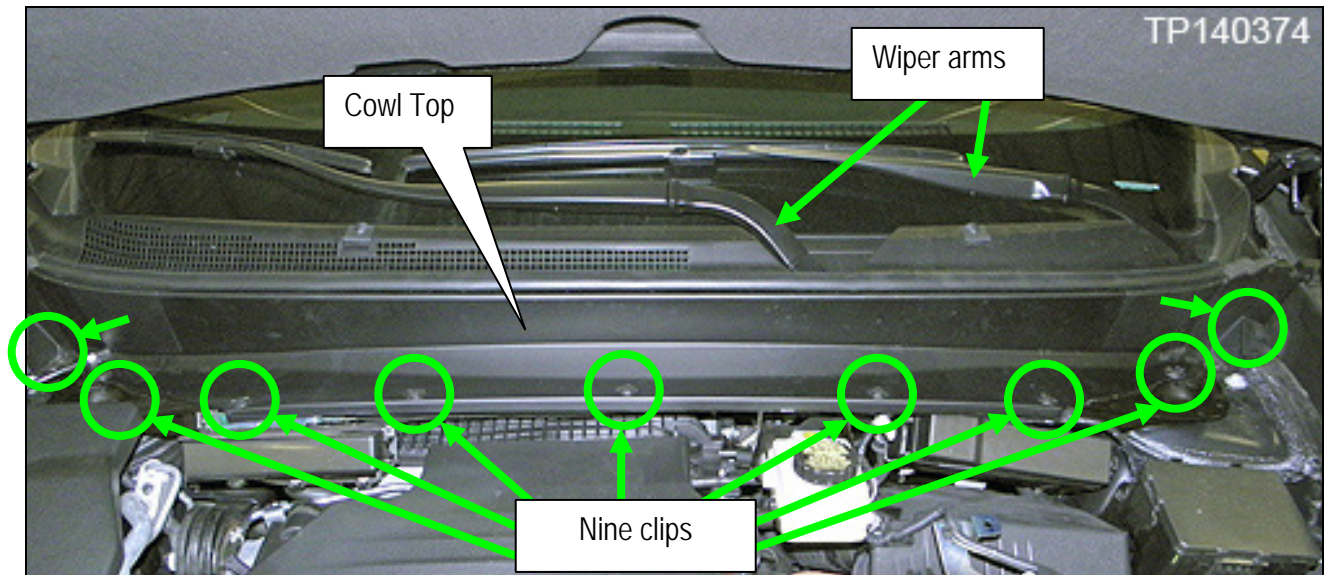

Figure 4

10. Disconnect windshield washer hose from the Cowl Top.

11. Remove the Cowl Top.

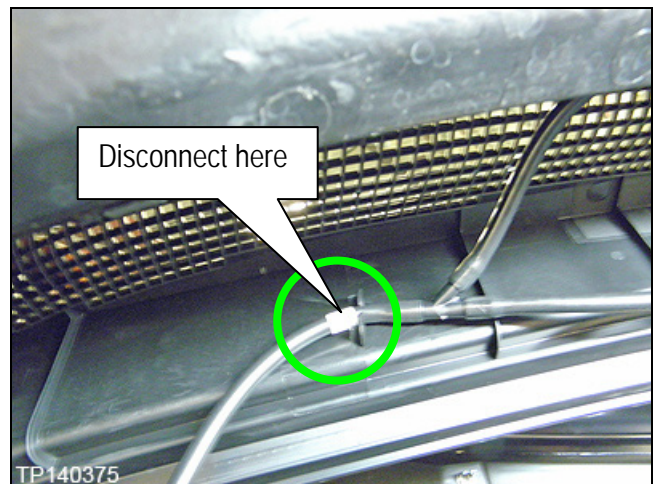

Figure 5

12. Remove the front air duct.
- Held by two 10 mm bolts.

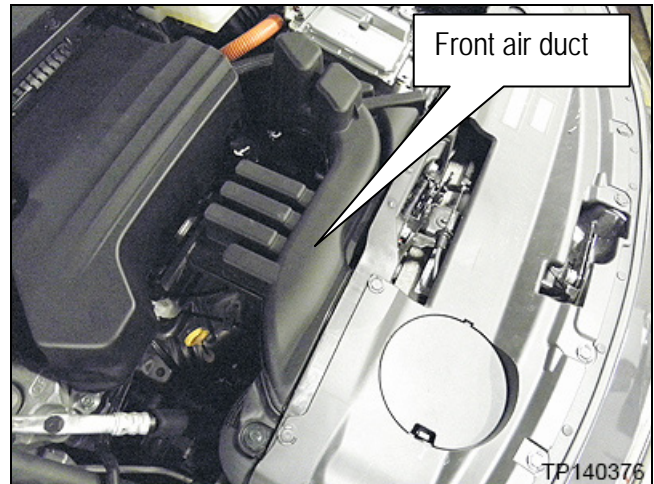

Figure 6

13. Disconnect the MAF sensor connector from the MAF sensor and then unclip the harnesses from the ECM bracket (shown in Figure 7).

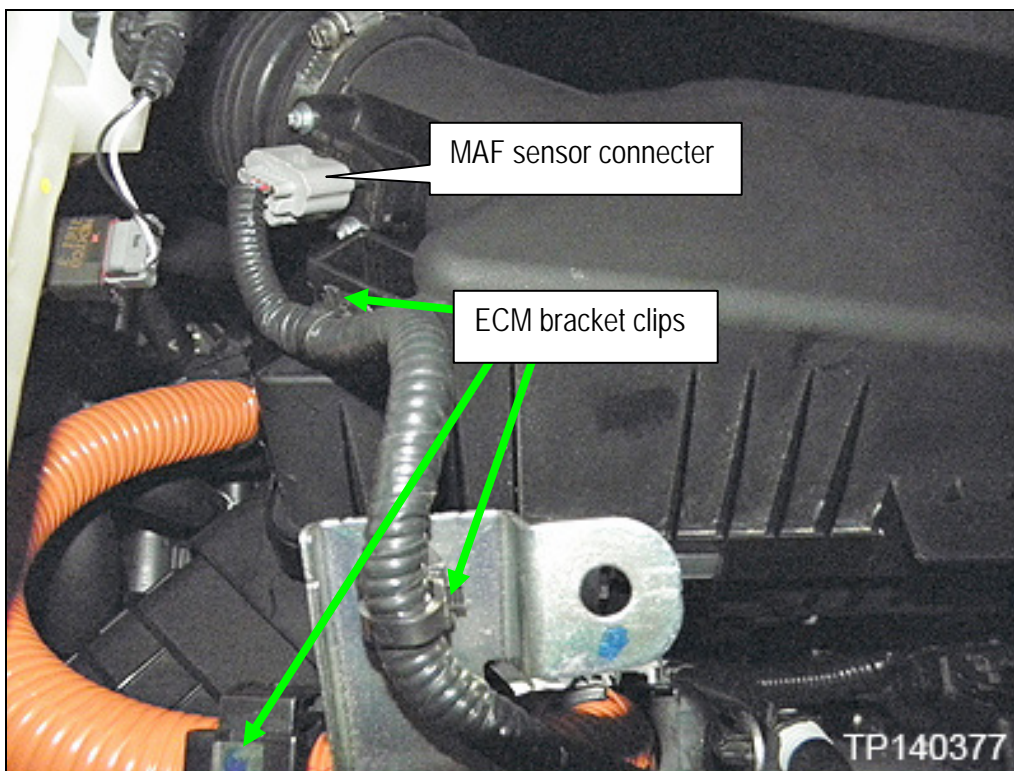

Figure 7

14. Of the three bolts holding the ECM/TCM (shown in Figure 8 and Figure 9) to the Traction Motor Inverter, loosen two and remove one.

NOTE: Figure 10 shows close up of the two bolts that are to be loosened.

Reassembly torque:
5.5 N·m (0.56 kg-m, 49 in-lb)

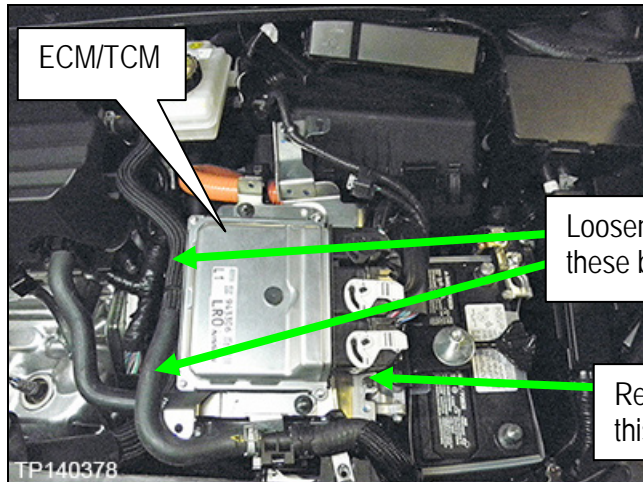

Figure 8

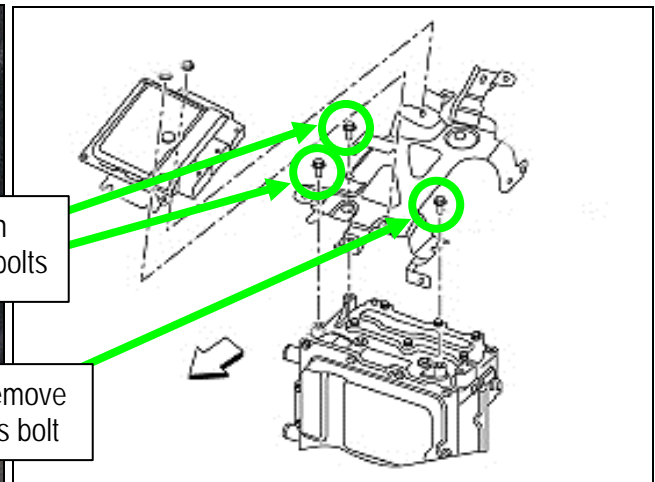

Figure 9

15. Slide the ECM/TCM off of the two remaining bolts.

NOTE: The ECM/TCM will not be completely removed and will only be loosened to allow the Air Cleaner Case to be removed.

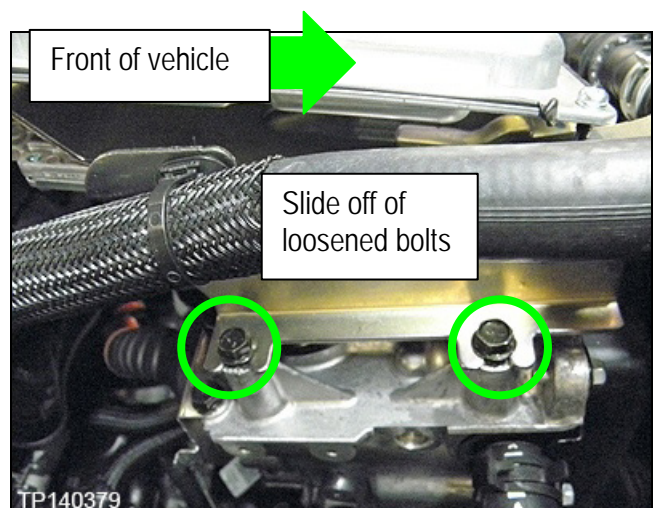

Figure 10

16. Release the clips for the top of the Air Cleaner Case Assembly and while holding the ECM/TCM out of the way, remove it with the air filter.

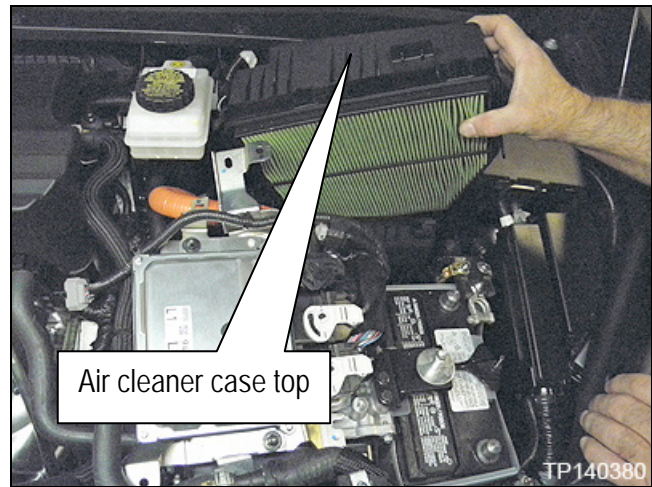

Figure 11

17. Remove one bolt holding the bottom of the Air Cleaner Case Assembly and then remove the Air Cleaner Case Assembly.

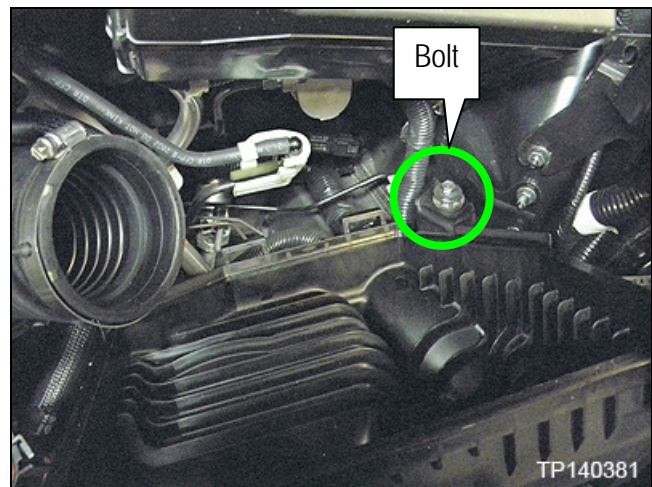

Figure 12

18. Place a transverse engine support bar on top of the strut towers (Essential tool J-47242).

NOTE: Three leg transverse engine support bar is required for this procedure.

19. Place a piece of wood or equivalent on the radiator core support under the third leg of the transverse engine support bar.

- The wood should be approximately 18" long and be oriented as shown in Figure 13.
- The third leg's foot should be centered directly over the top core support.

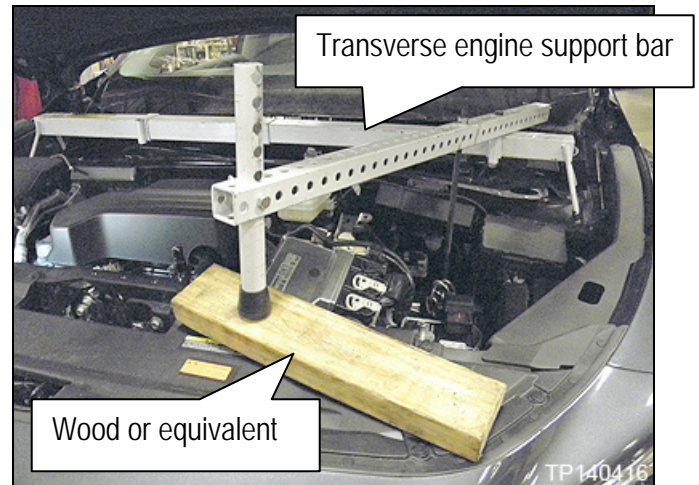

Figure 13

NOTE: Later in this procedure the Front Suspension Member (engine cradle) will be removed / lowered from under the engine. The engine and transmission will be held in place by the engine mount at the front of the engine and the support bar that was just installed.

20. Raise the vehicle and remove both of the front wheels.

21. Remove both of the Front Fender Protector Side Covers (Figure 14).

- Each side is held in place by four clips.

NOTE: Right side shown. Left side is similar.

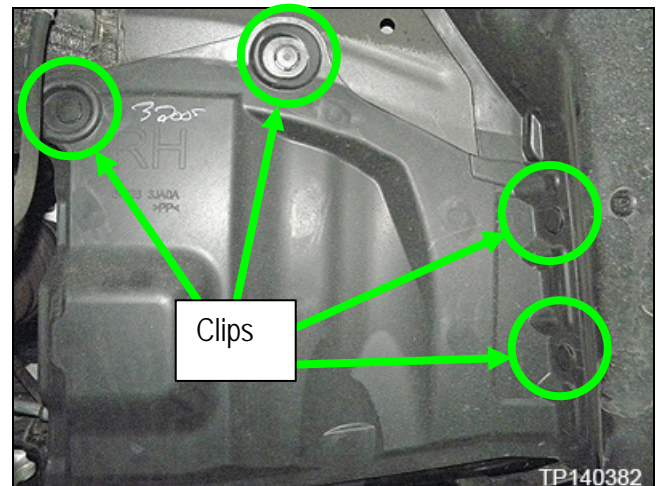

Figure 14

22. Remove both (left and right sides of vehicle) of the Front Lower Transverse Links nut/bolts from the Steering Knuckles.

- Discard the Front Lower Transverse Link nuts.

Reassembly torque:
97 N•m (9.9kg-m, 72 ft-lb)

23. Remove both (left and right sides of vehicle) of the Front Steering Rack Tie Rod End nuts from the Steering Knuckles and then remove the tie rod ends.

Reassembly torque:
45 N•m (4.6 kg-m, 33 ft-lb)

24. Disconnect both Stabilizer Connecting Rods from both of the struts.

Reassembly torque:
84 N•m (8.6 kg-m, 62 ft-lb)

NOTE: The right side of the vehicle is shown in Figure 15 and Figure 16; remove nuts and bolts for both sides (left and right).

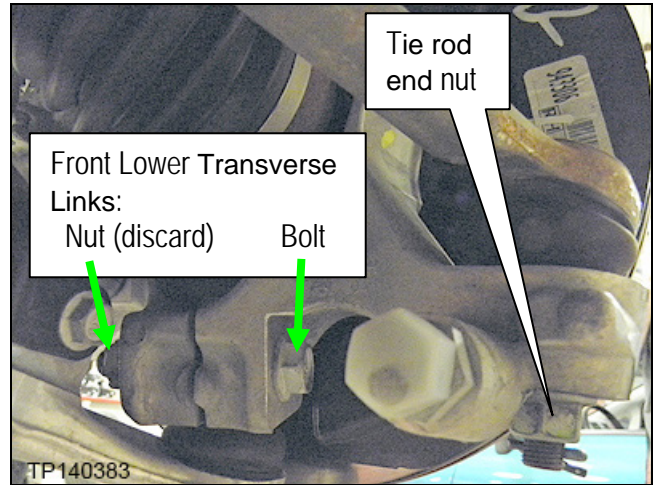

Figure 15

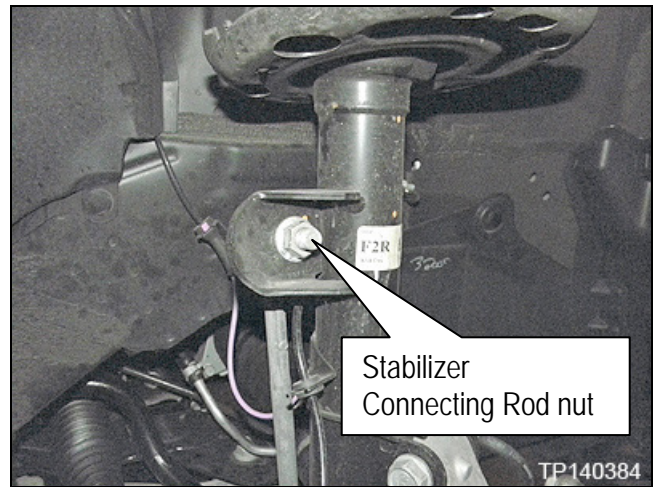

Figure 16

25. Disconnect the oil pressure switch (Figure 18).

26. Remove the engine drive belt from the supercharger (Figure 17 and Figure 18):

- a. Securely hold the hexagonal part (A) of drive belt auto-tensioner (1) using suitable tool, and move in the direction of arrow (loosening direction of tensioner).

WARNING: Avoid placing hand in a location where pinching may occur if the holding tool accidentally comes off.

- b. Insert a rod approximately 6.0 mm (0.24 in) in diameter through the rear of the drive belt auto-tensioner into retaining boss (B) to lock drive belt auto-tensioner pulley.

NOTE: Leave drive belt auto-tensioner pulley arm locked until drive belt is installed again.

- c. Remove drive belt from drive belt auto-tensioner and then remove it from the other pulleys.

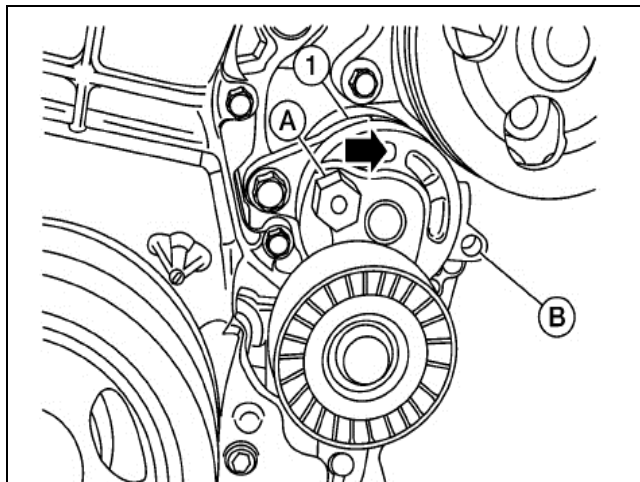

Figure 17

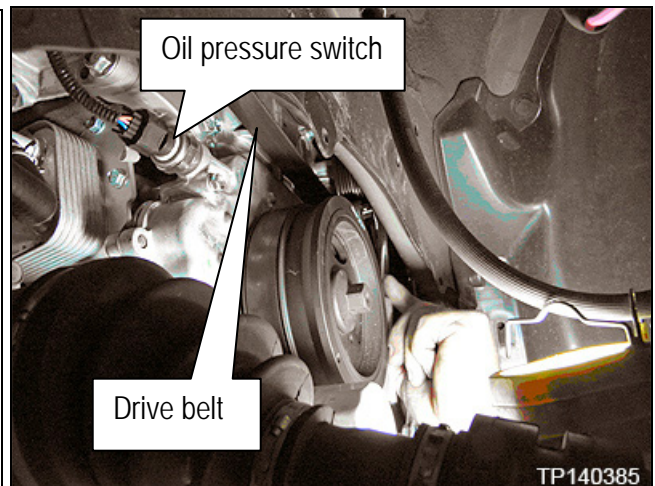

Figure 18

27. Remove the four bolts attaching the power steering High Pressure Piping and Low Pressure Piping (power steering hose and line) to the engine cradle and power steering rack (Figure 19).

NOTE: Do not remove the power steering hose and line from the vehicle.

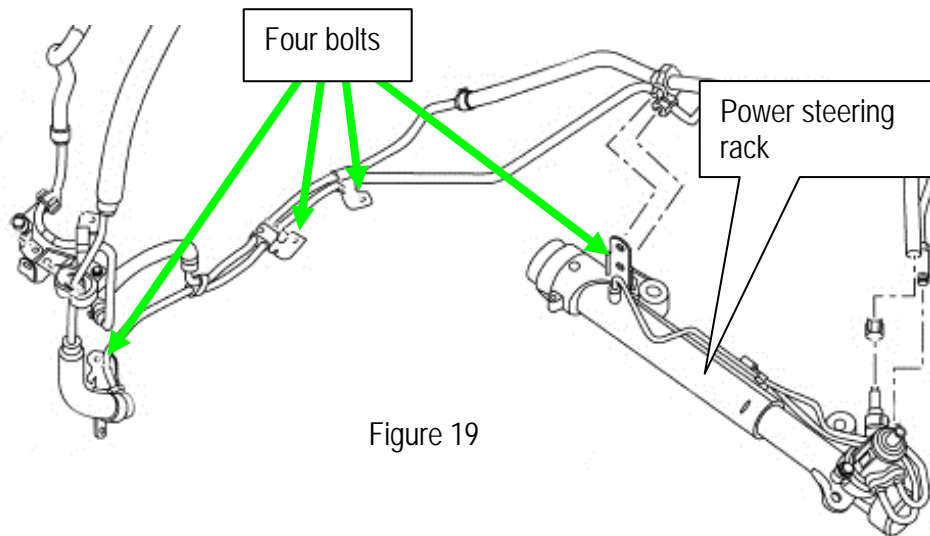

Figure 19

28. Remove two 16 mm bolts from the Engine Mount Insulator Bracket (Figure 20).

29. Attach a chain to the CVT as shown in Figure 20.

- Chain should be a minimum of 45 inches; more if needed.
- Bolts should be 40 mm long grade 10.9 (or higher) with washers.

NOTE: Be careful not to damage the Primary Speed Sensor.

Reassembly torque:
80 N•m (8.2 kg-m, 59 ft-lb)

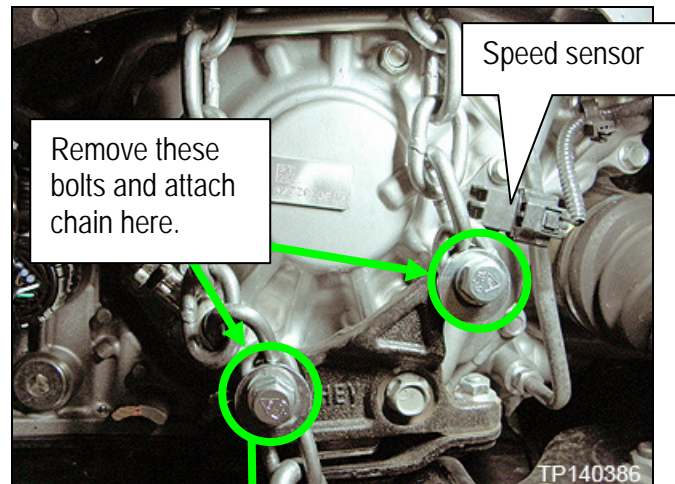

Figure 20

Bolt with washer shown in Figure 21.

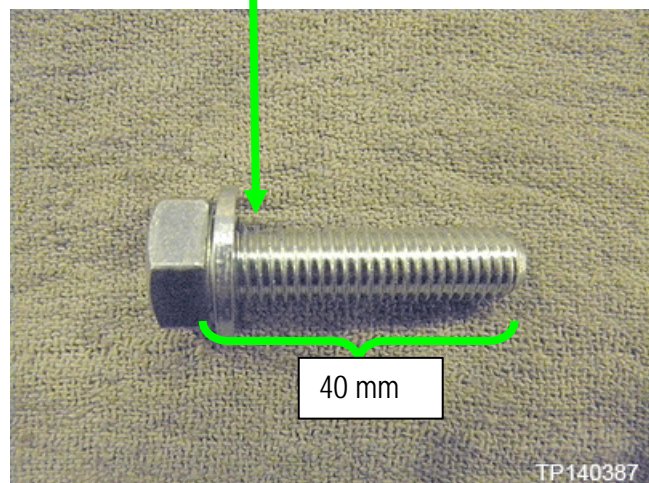

Figure 21

30. Guide the chain between the CVT and left side frame rail so that it can be reached from the top.

NOTE: This chain will be attached to the engine support bar later in the procedure.

31. Remove the three bolts attaching the Engine Mount Insulator (LH) to the engine cradle.

- Leave the mount and bracket in place.

Reassembly torque:
70 N•m (7.1 kg-m, 52 ft-lb)

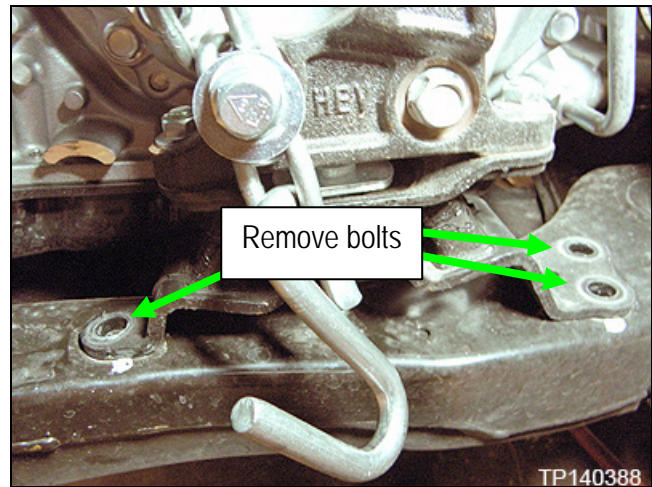

Figure 22

32. Remove the Front Under Cover (Figure 23).

- Attached with sixteen clips.

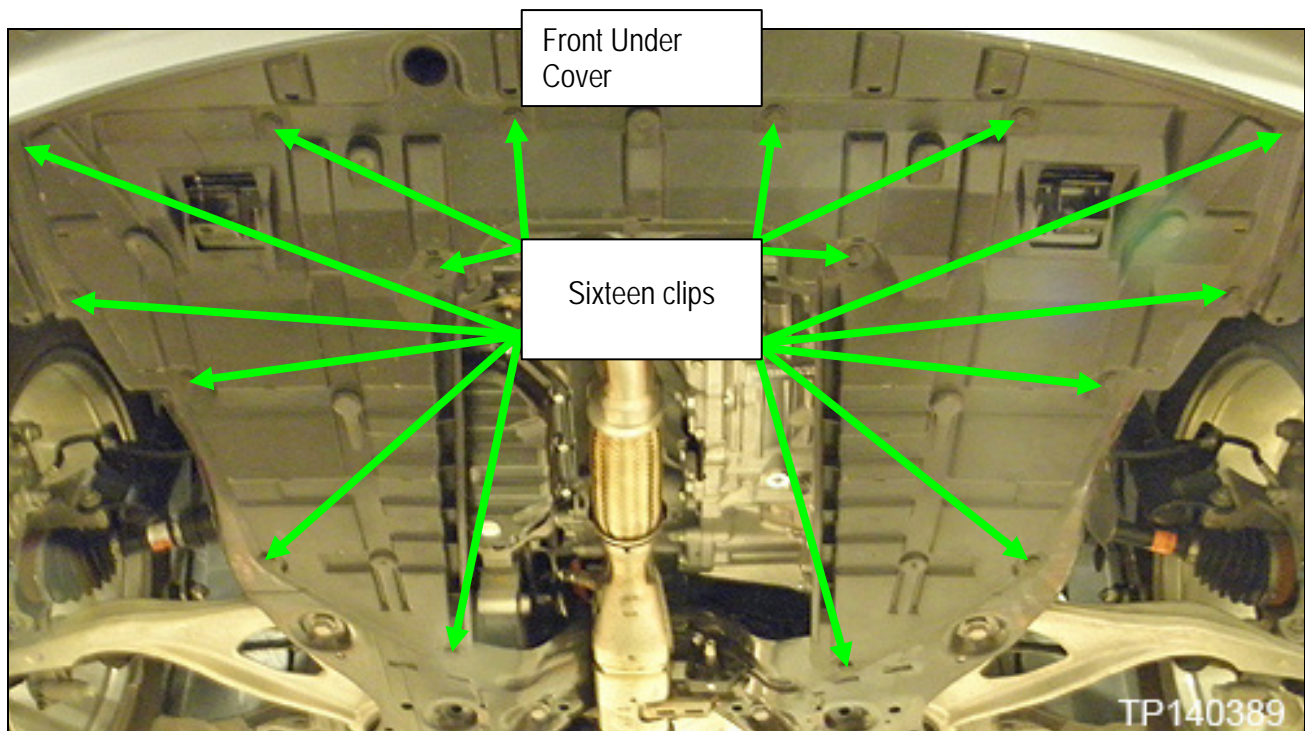

Figure 23

33. Disconnect the rear O2 sensor harness connector and then unbolt and remove the Front Exhaust Tube.
- Discard two exhaust o-ring gaskets shown in Figure 24.
 - Discard three exhaust nuts shown in Figure 24.

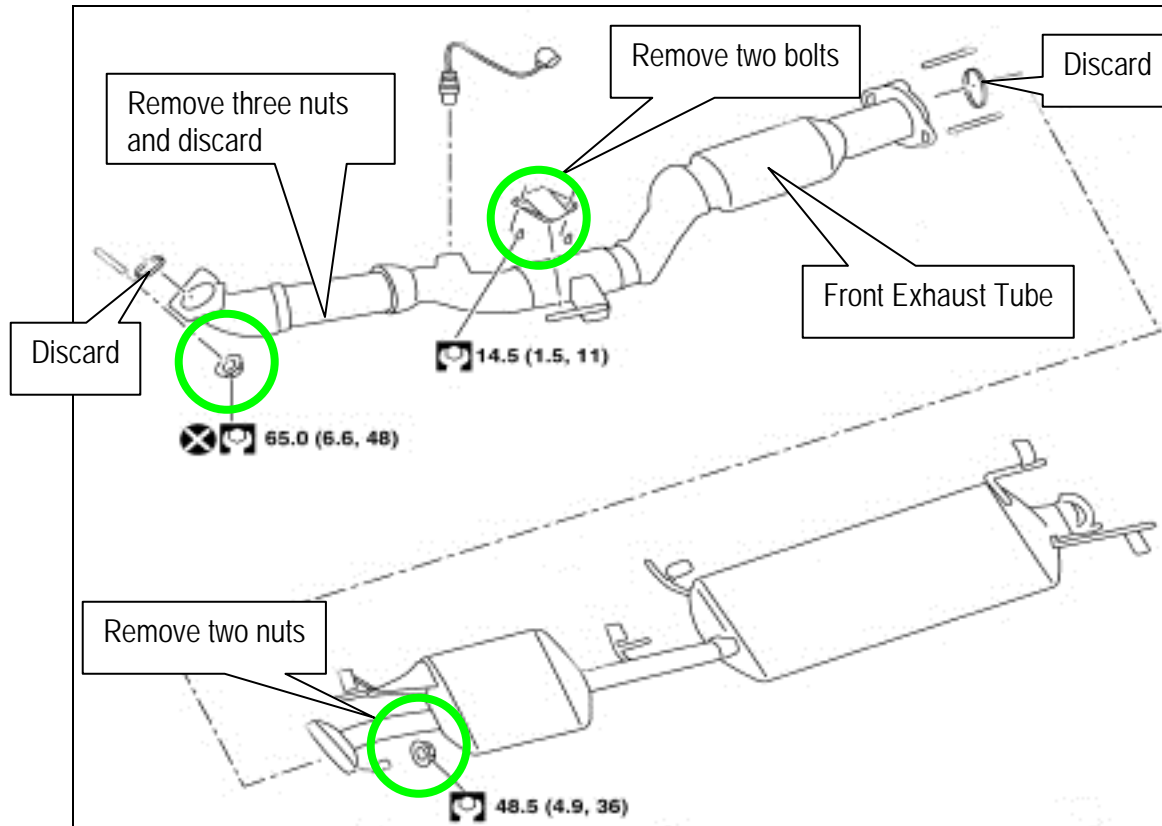

Figure 24

34. Remove the heat shield above the Front Exhaust Tube.

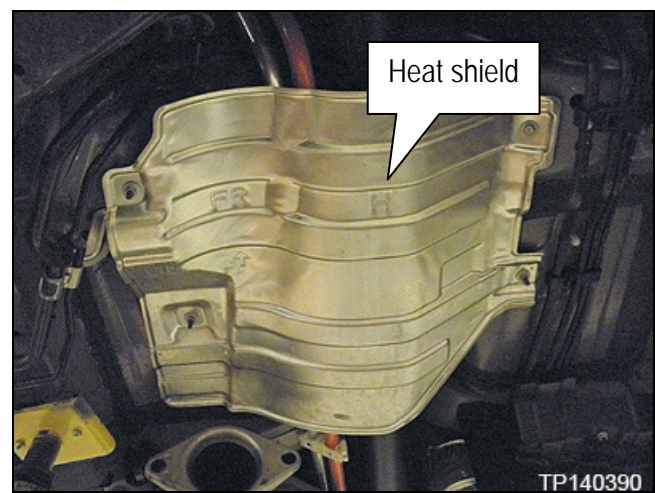

Figure 25

35. Unbolt the Rear Engine Mount Insulator from the engine cradle (four bolts).

- Leave the mount attached to the engine/CVT.

Reassembly torque:
55 N•m (5.6 kg-m, 41 ft-lb)

NOTE:

- The Rear Engine Mount Insulator is shown with the engine cradle out of the vehicle for reference.
- The left rear of the engine cradle shown from the top in Figure 26.

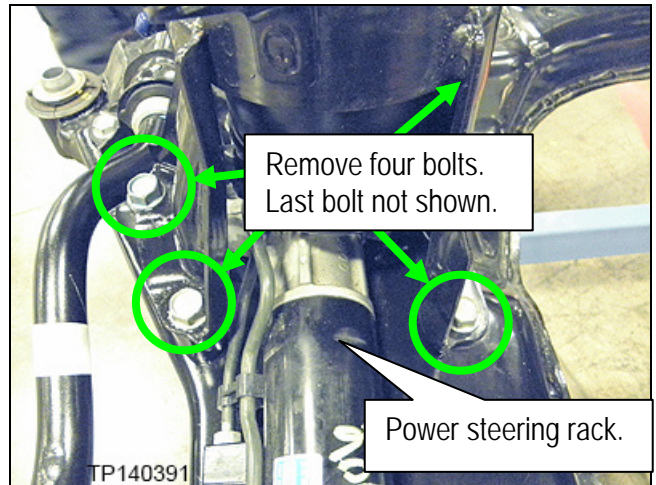

Figure 26

36. Lower the vehicle.

37. Attach the chain from steps 28-30 to the transverse engine support bar "j-hook".

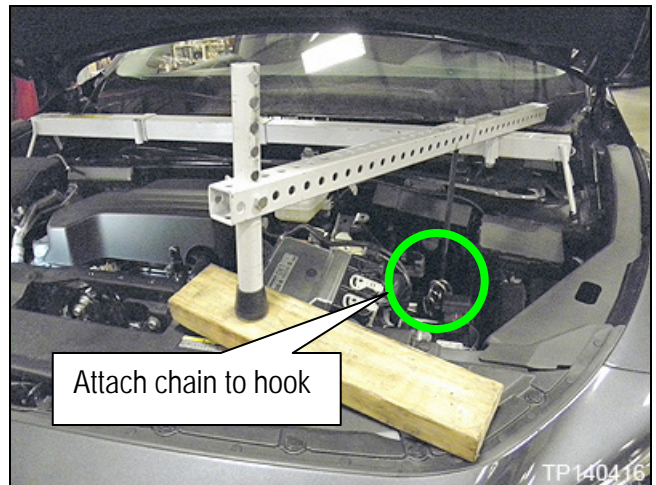

Figure 27

38. Remove the top nut (18mm) from the Front Engine Mount Insulator (next to radiator core support).

Reassembly torque:
103 N•m (11 kg-m, 76 ft-lb)

39. Tighten the transverse engine support bar j-hook nut until the CVT mount (Figure 22, page 11) lifts slightly off of the engine cradle.

- Approximately 1 mm.

40. Raise the vehicle, as needed, high enough to comfortably perform the following steps.

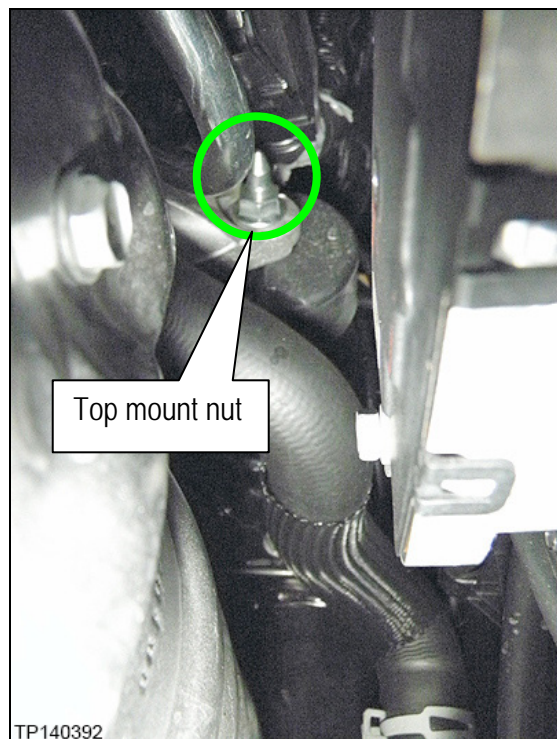

Figure 28

41. Disconnect the Front Engine Mount Insulator harness connector.

42. Disconnect the Front Engine Mount Insulator ground wire from the CVT.

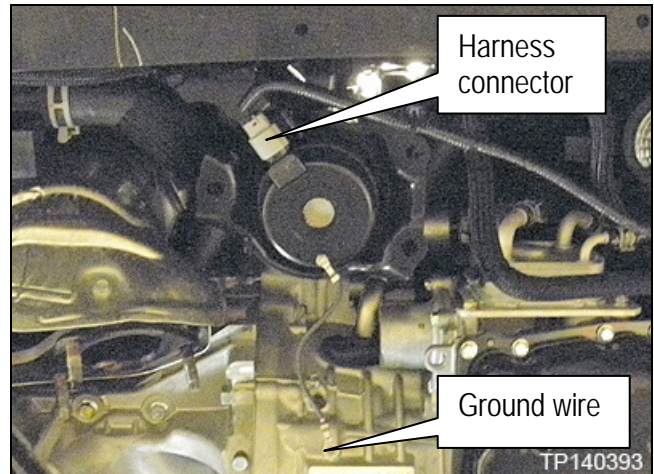

Figure 29

43. Unbolt the Rear Lower Torque Rod from the engine.

Reassembly torque:
103 N•m (11 kg-m, 76 ft-lb)



Figure 30

44. Disconnect the power steering hose and line from the power steering rack and then cap them to prevent leakage.

Reassembly torque for Power steering line:
33.4 N•m (3.4 kg-m, 25 ft-lb)

45. Disconnect the input shaft from the steering rack.
- Lock the steering wheel in place with an alignment machine steering wheel holder or equivalent.

CAUTION: Do not allow steering wheel to rotate or Spiral Cable damage could occur.

Reassembly torque:
26.5 N•m (2.7 kg-m, 20 ft-lb)

46. Unbolt the Lower Radiator Hose Support from the front of the engine cradle.

47. Disconnect the three wiring harness clips and the one hose clip from the left front of the engine cradle.
- The harness clip not shown is attached to the engine cradle, at Front Engine Mount Insulator bracket.

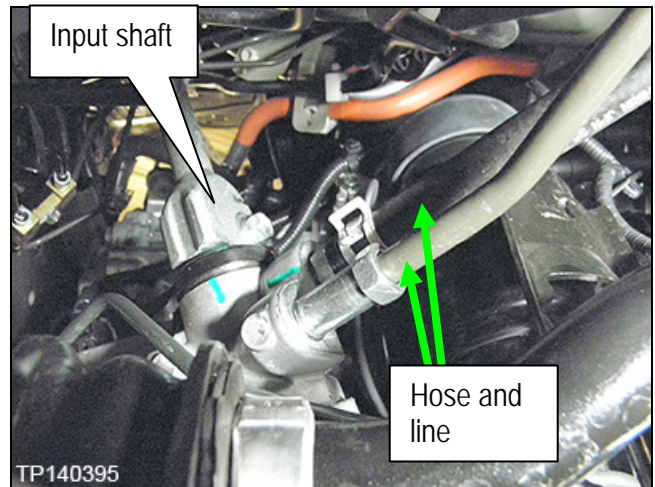

Figure 31

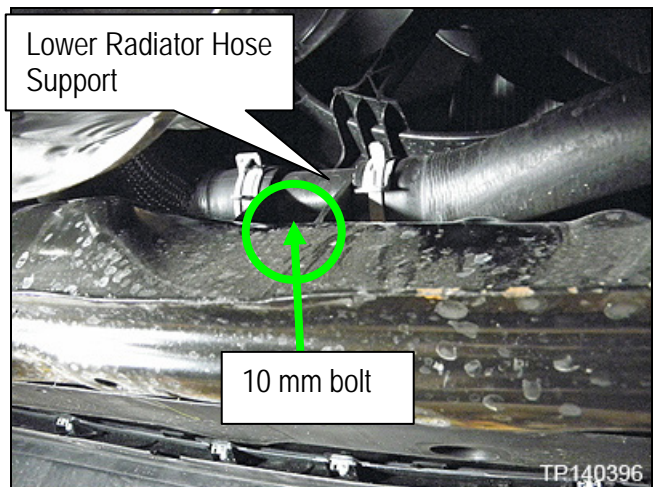

Figure 32

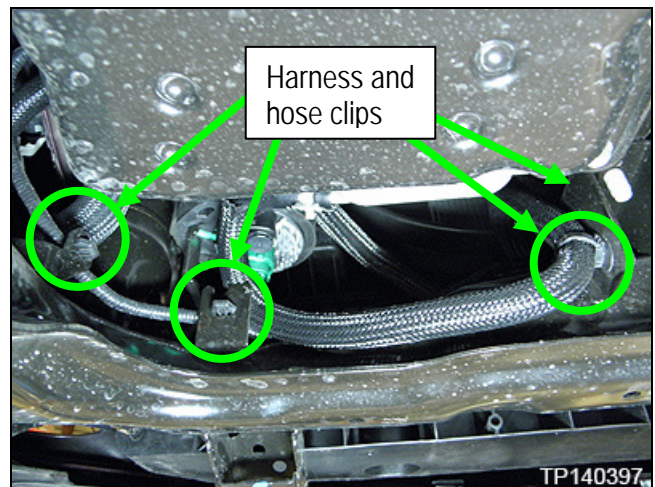

Figure 33

48. Place a support table under the engine cradle and lower the vehicle just above the table.
 - Use engine support table J-47242 or equivalent.
49. Position and adjust the table to properly support the engine cradle.
50. Lower the vehicle so the support table is supporting the engine cradle.

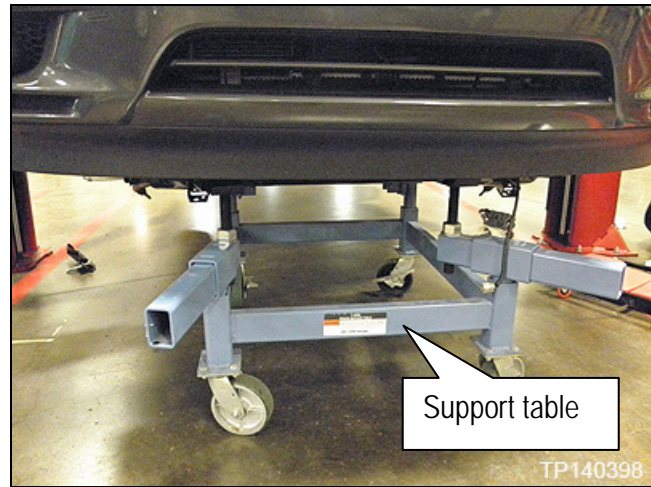

Figure 34

51. Remove the right and left Front Suspension Member Stay's bolts (Figure 35) and the engine cradle bolts (Figure 36).

NOTE: Right side Front Suspension Member Stay shown. Left side is similar.

Reassembly torque for Front Suspension Member Stays:
52 N•m (5.3 kg-m, 38 ft-lb)

Reassembly torque for engine cradle bolts:
155 N•m (16 kg-m, 114 ft-lb)

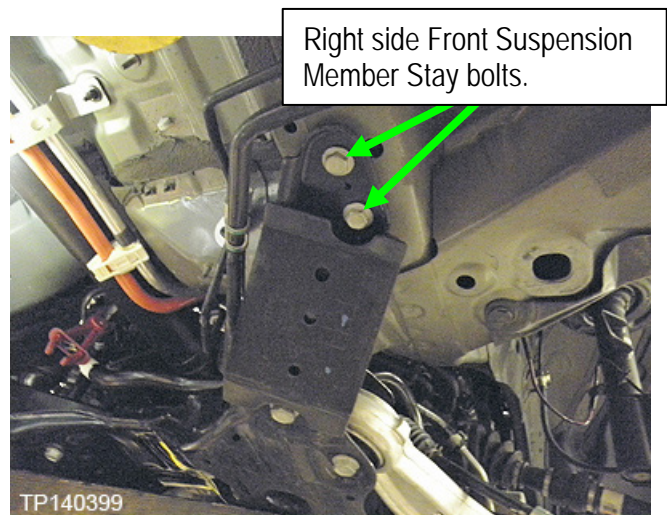

Figure 35

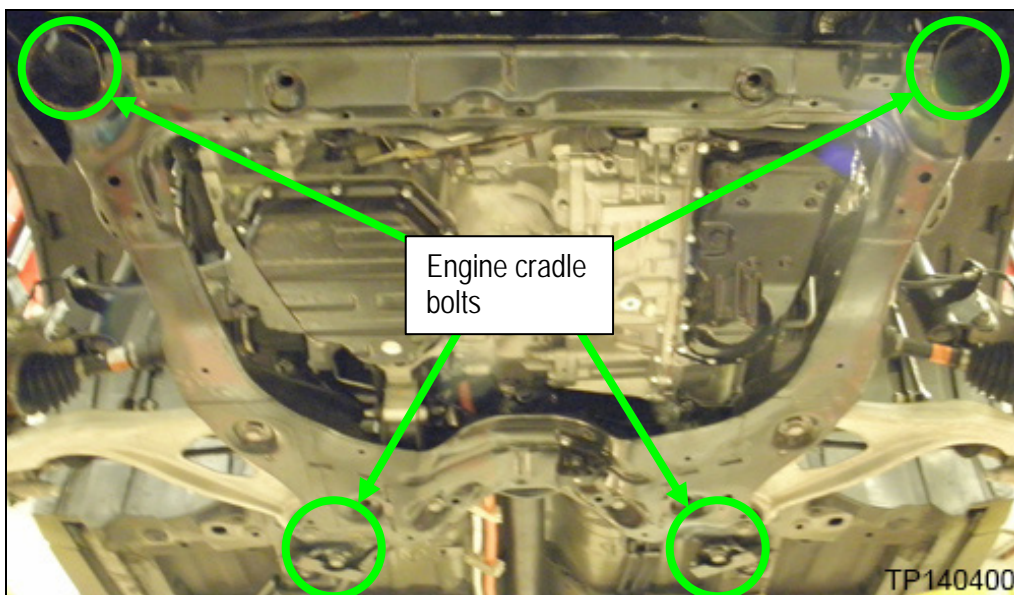

Figure 36

52. After the engine cradle is unbolted:
 - a. Carefully raise the vehicle until it is clear of the engine cradle (confirm that all of the components have been detached).
 - b. Move the engine cradle out of the way.
 - c. Continue to raise the vehicle to a comfortable work height for the following steps.

53. Is the vehicle an AWD?

- If yes:
 - a. Place an alignment mark on the propeller shaft and Transfer Case flanges.
 - b. Support the front half of the Propeller Shaft Assembly, at the transfer case, and then unbolt it (Figure 37).
 - Discard bolts.

Reassembly torque:
49 N•m (5.0 kg-m, 36 ft-lb)

- If not an AWD, skip to step 54.

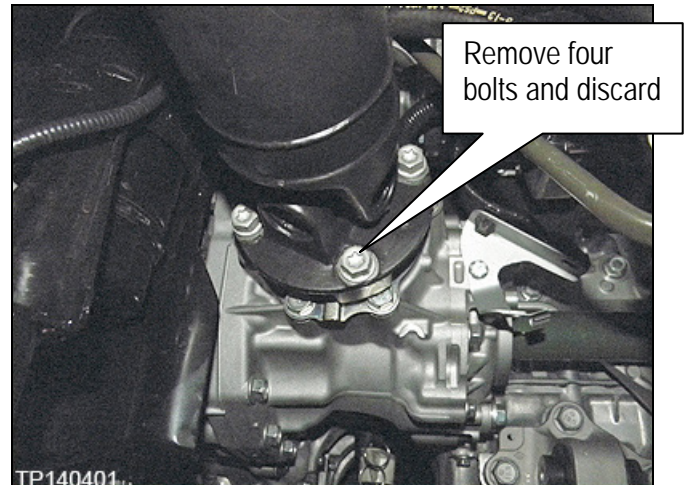

Figure 37

54. Disconnect the Supercharger Bypass Valve Control Actuator harness.
55. Unclip the two pipe brackets holding the coolant hoses for the engine oil cooler and then secure the coolant hoses out of the way.
56. If the vehicle is an AWD, unbolt the O2 sensor harness connector bracket from the transfer case, and if a 2WD only disconnect O2 sensor harness connector.
 - For AWD vehicles this will make room for the supercharger to be removed.

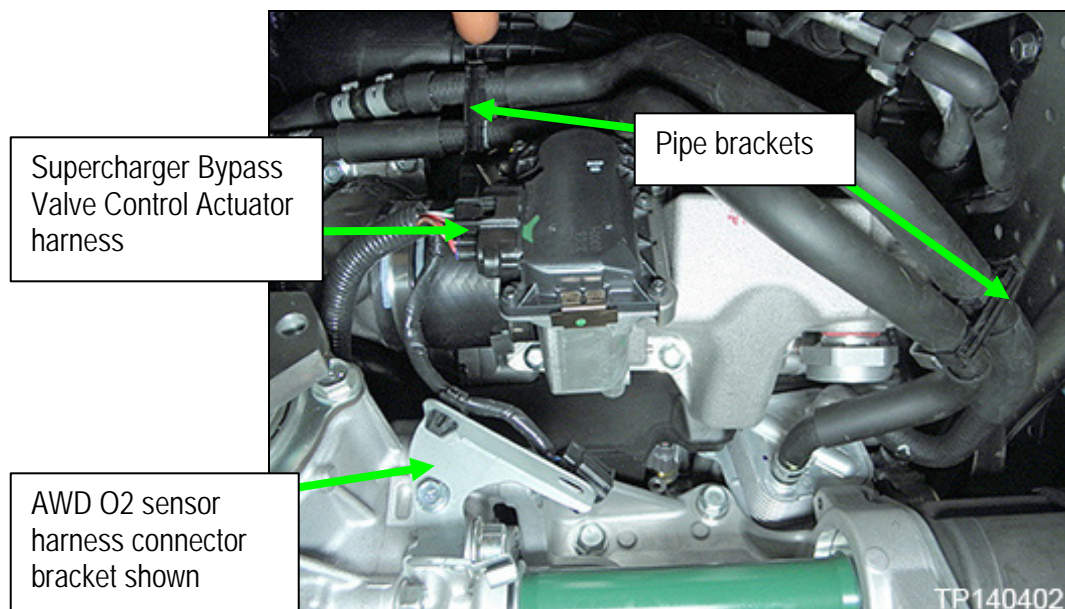

Figure 38

57. Place an alignment mark on the Air Duct and the Supercharger Inlet.

IMPORTANT: The alignment mark will be used for reassembly to align the Air Cleaner Case Assembly.

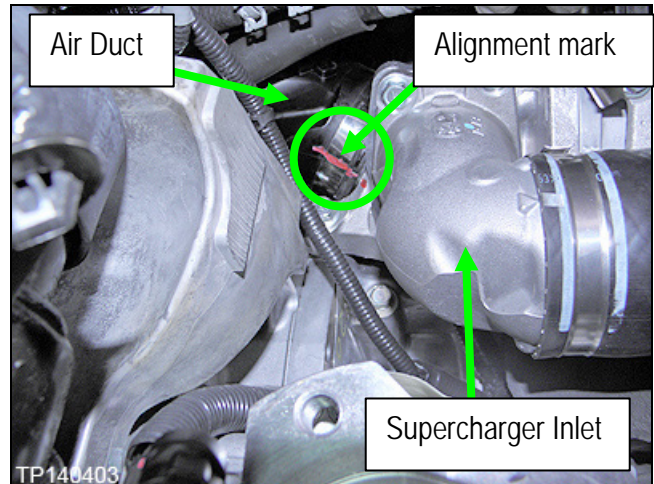

Figure 39

58. Loosen the band clamp of the Air Duct on the Supercharger Inlet and then remove it from Supercharger Inlet.

- Leave the Air Duct in place.

59. Unclip coolant hoses from supercharger pipe bracket next to the Inlet Pipe.

NOTE: This bracket will be removed with the supercharger.

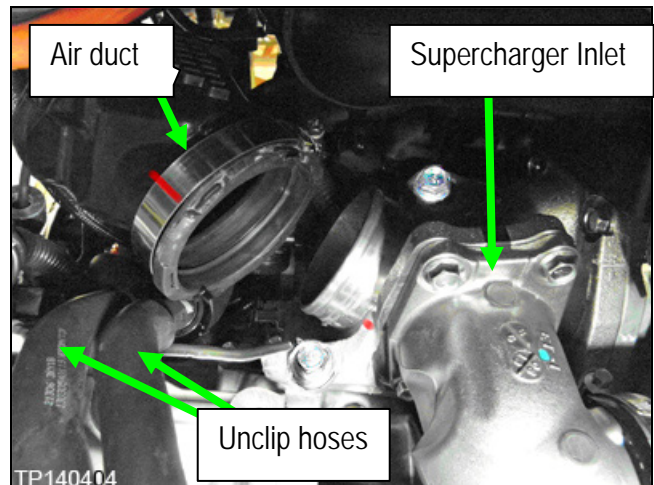

Figure 40

60. Unbolt the supercharger "top" Air Inlet Tube from the "lower" Air Inlet Tube.

- Discard the gasket between the "top" Air Inlet Tube and the "lower" Air Inlet Tube.

Reassembly torque:
22 N•m (2.2 kg-m, 16 ft-lb)

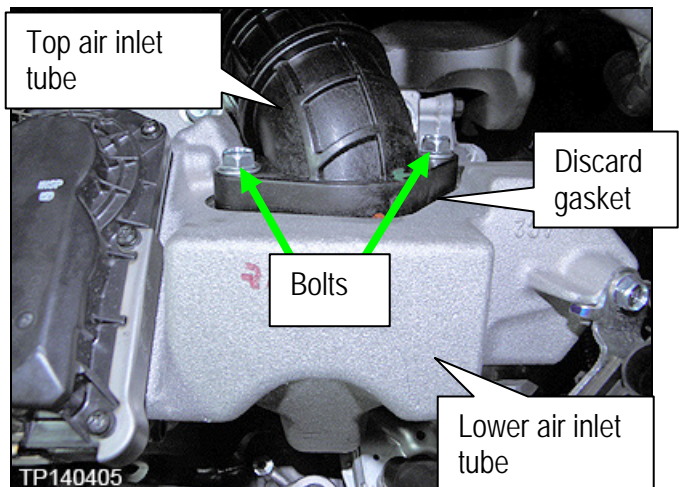

Figure 41

NOTE: In the next step the driveline (engine) will be slightly rotated / tilted to allow the removal of the supercharger.

61. Using a ratcheting strap:
 - a. Attach one side to the core support.
 - b. Attach the other side to the bolt hole on the engine that the torque strut occupied.
 - c. Take up the slack until the bottom of the engine starts to rotate forward.



Figure 42

62. Remove the three bolts and one nut (Figure 43 and Figure 44) that attach the supercharger assembly to the engine.

Reassembly torque:
45 N•m (4.6 kg-m, 33 ft-lb)

63. Remove the supercharger assembly from the engine.

64. If the supercharger will not come off of the single stud, rotate the engine forward slightly more with the ratcheting strap until it will clear.

NOTE: Retain the Supercharger Insulator (high density foam) that is between the engine and the supercharger for reassembly.

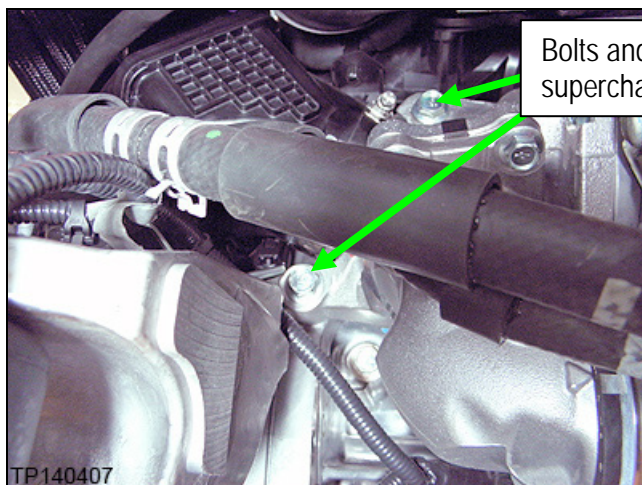

Figure 43

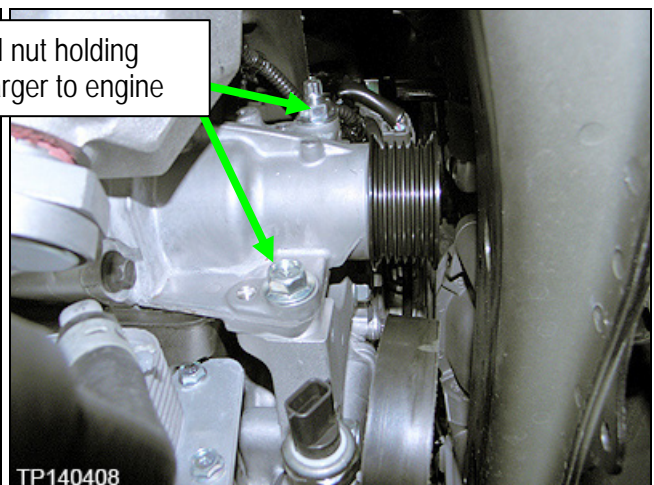

Figure 44

NOTE: For the following steps do not loosen or separate the hose that connects the Supercharger Inlet and Air Inlet Tube (Figure 45).

65. Place the supercharger assembly on a work bench for disassembly.

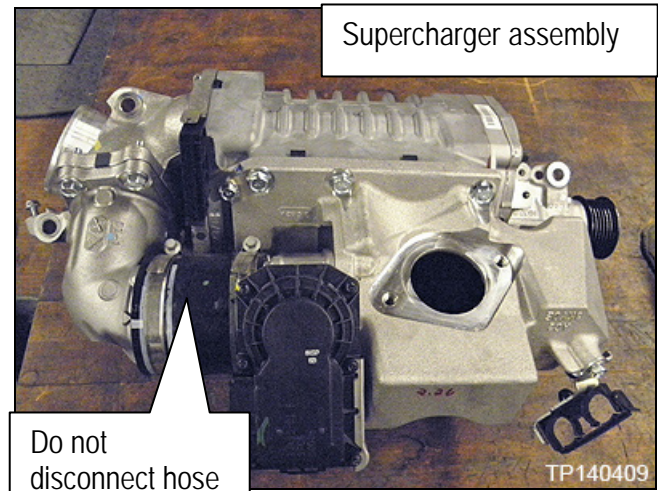

Figure 45

66. Remove the twelve bolts that attach the Supercharger Inlet and Air Inlet Tube to the supercharger.

- Six bolts on the side and six on top.
- Discard both gaskets.

Reassembly torque:
22 N•m (2.2 kg-m, 16 ft-lb)

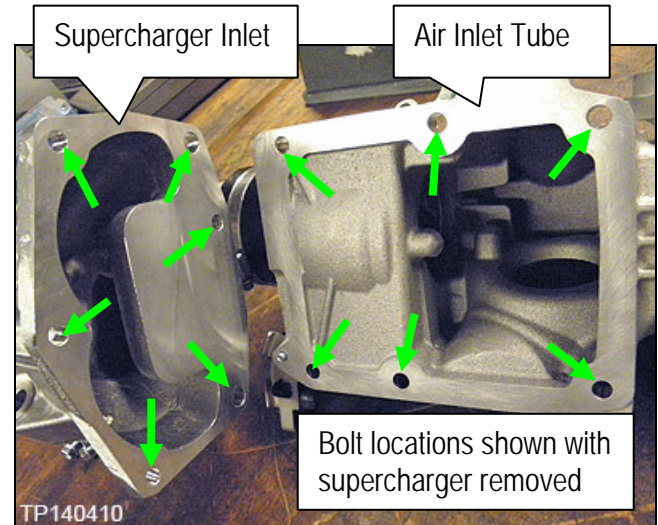

Figure 46

67. Slide the new side gasket over the shuffle pins.

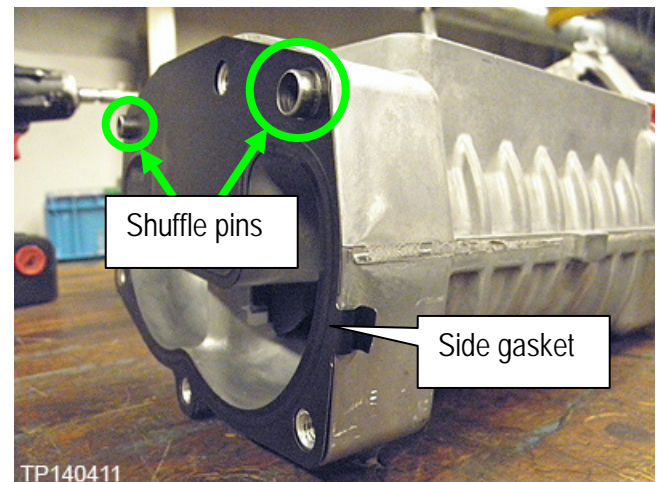

Figure 47

68. Slide the Supercharger Inlet onto the shuffle pins and then install the six side bolts finger tight.

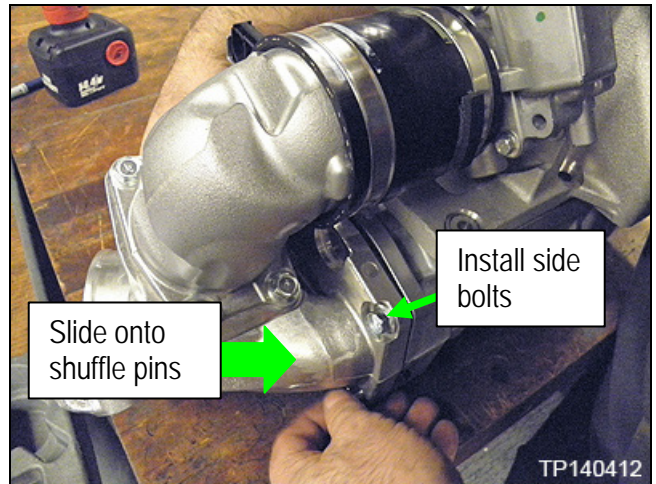

Figure 48

69. Lift the Air Inlet Tube up slightly and then gently insert the new Air Inlet Tube to supercharger gasket.

- The tabs (Figure 50) should point toward the supercharger.

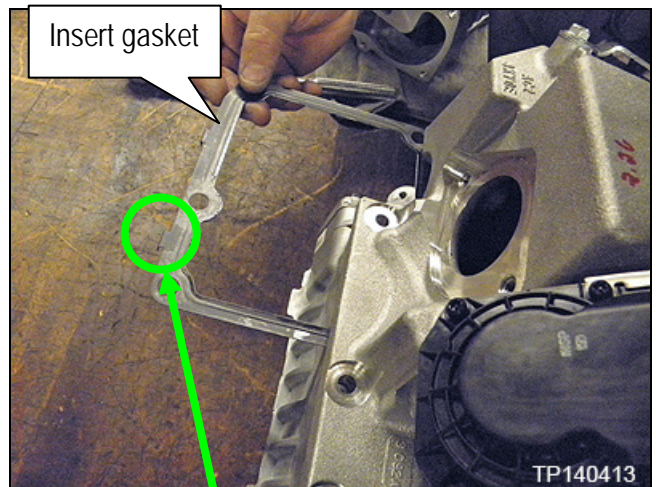

Figure 49

70. Align the holes of the Air Inlet Tube, gasket and the supercharger.

71. Insert the six Air Inlet Tube bolts finger tight.

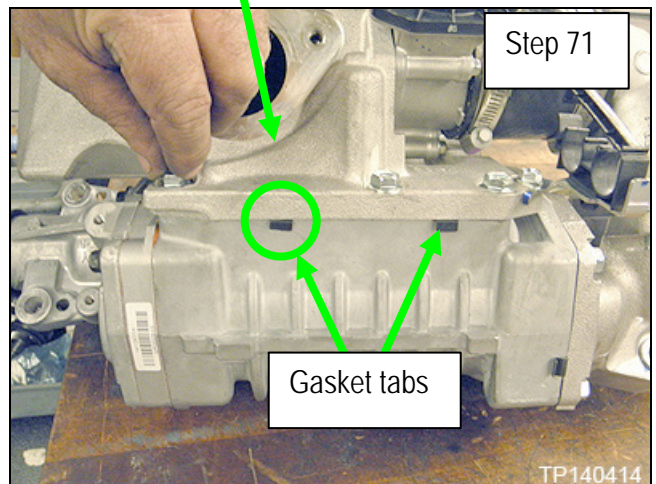

Figure 50

72. Torque all twelve bolts to 22 N•m (2.2 kg-m, 16 ft-lb).

73. To hold the supercharger insulator foam in place for installation, attach it to the supercharger with several pieces of tape (Figure 51).

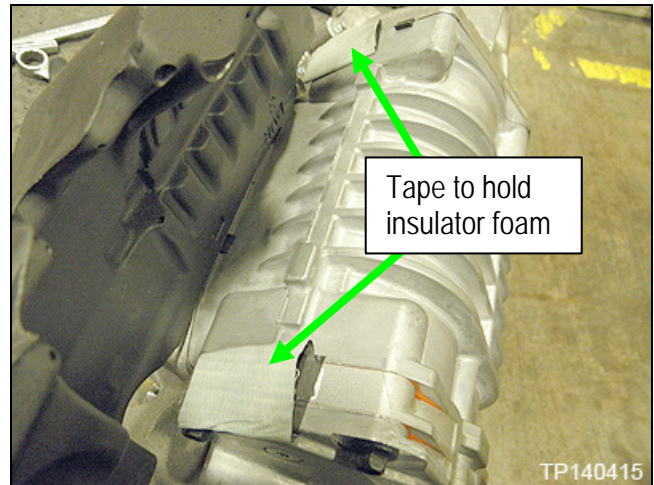

Figure 51

74. Install the supercharger onto the vehicle and torque the one nut and three bolts in the order shown in Figure 52.

Reassembly torque:
45 N•m (4.6 kg-m, 33 ft-lb)

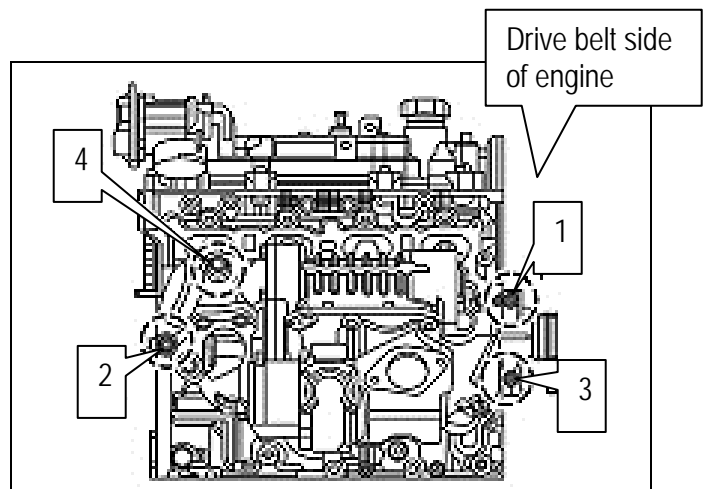

Figure 52

75. Reassemble the remaining components in the reverse order.

76. Reconnect the negative battery cable and then the HEV Service Plug.

77. Reset the clock and the radio settings written down from page 2.

78. Check the level of power steering fluid and fill as needed.

79. Purge the air from Power Steering system.

- Refer to the Electronic Service Manual (ESM) section **ST-Steering System**, for the procedure to purge air from the steering system.

80. Perform Idle Air Volume Learning.

- Refer to the ESM section **EC-Engine Control System**, for the procedure to perform Idle Air Volume Learning.

Continue to the next page.

81. Adjust the Steering Angle Sensor Neutral Position.

- Refer to the ESM section **BRC-Brake Control System**, for the procedure to adjust the steering angle sensor neutral position.

82. Reinitialize and check the Anti-Pinch Function for the Back Door.

- Refer to the ESM section **DLK-Door & Lock**, for the procedure to reset/initialization the Back Door Anti-Pinch Function.

83. Restart the entry/exit function for Automatic Drive Positioner System.

- Open and close the driver's door more than 2 times with the ignition switch in the LOCK position.

84. If equipped with navigation: Inform the customer that some memory settings in the navigation system may need to be reset.

PARTS INFORMATION

| Description | PART # | Quantity |
|-----------------------------------------|-------------|----------|
| Supercharger | 14110-3KY0A | 1 |
| Supercharger Inlet gasket | 14115-3KY0A | 1 |
| Air Inlet Tube gasket (metal) | 14465-3KY1B | 1 |
| Air Inlet Tube gasket (red) | 14465-3KY0C | 1 |
| Exhaust gasket (front tube to muffler) | 20695-ED10E | 1 |
| Exhaust gasket (manifold to front tube) | 20691-19U00 | 1 |
| Exhaust nut | 01225-N0011 | 3 |
| Front Lower Transverse Link Nut | 40262-JA000 | 2 |
| Driveshaft bolts | 37120-JD00B | 4 |

CLAIMS INFORMATION

2WD - Model

Submit a Primary Part (PP) type line claim using the following claims coding:

| DESCRIPTION | PFP | OP CODE | SYM | DIA | FRT |
|---------------------------------|-----|---------|-----|-----|-----|
| Replace Supercharger Assy – 2WD | (1) | DX40AA | ZL | 32 | 3.9 |

1. Reference the Parts Information Table and use the applicable Supercharger Part Number (14110-*****) as the Primary Failed Part.

AWD - Model

Submit a Primary Part (PP) type line claim using the following claims coding:

| DESCRIPTION | PFP | OP CODE | SYM | DIA | FRT |
|---------------------------------|-----|---------|-----|-----|-----|
| Replace Supercharger Assy – AWD | (1) | DX40PA | ZL | 32 | 4.0 |

1. Reference the Parts Information Table and use the applicable Supercharger Part Number (14110-*****) as the Primary Failed Part.

