

IMPORTANT INFORMATION

Please inform and provide a copy of this document to every person in your dealership with campaign-related responsibilities, including Service, Parts and Accounting personnel. By law, dealers must correct, prior to delivery for sale or lease, any vehicle that fails to comply with an applicable Federal Motor Vehicle Safety Standard or that contains a defect relating to motor vehicle safety. **If you have questions regarding this or any other campaign, please contact Warranty.**



Service Action

Code: 19J5

**Subject: 2012 and 2013 MY Golf R
Coolant Pump**

March 18, 2014

Problem Description

Some customers of 2012 and 2013 model year Golf R vehicles have reported engine compartment noise and hard start issues with their vehicles. Volkswagen has determined that the coolant pump is the source of these concerns.

Corrective Action

Replace the coolant pump.

Affected Vehicles

U.S.A.:

2012 and 2013 MY Golf R

CANADA:

2012 MY Golf R

Verify the open Campaigns/Actions screen in Elsa to determine if the VIN# applies to this Campaign/Action

NOTE:

- *Elsa is the only valid campaign inquiry/verification source. Check Elsa on the day the campaign work will be performed to verify vehicle eligibility for the repair in order to receive claim payment consideration. Campaign status must show "open".*
- *If this repair appears to have already been performed on the vehicle but the code still shows open in Elsa, contact Warranty before proceeding further, e.g. a dealer may have recently performed this repair but not yet entered a claim for it in the system.*
- *Elsa may also show additional open action(s); if so, inform your customer - this work can be done while the vehicle is in for this campaign.*
- *Contact Warranty if you have any questions.*

Inventory Vehicle Open Campaign/Action Report (VIM)

On or about March 18, 2014, affected vehicles will be listed on the Inventory Vehicle Open Campaign Action report under My Dealership Reports (found on www.vw.com & VIM). A list will not be posted for dealers who do not have any affected vehicles.

Parts Information and Allocation

There will be no parts allocation for this action. Parts will be available on upper order limits. Please submit your requests via e-mail to upperorderlimits@vw.com.

If you have questions regarding parts, please contact the Parts Helpline at 800-767-6552.

Owner Notification Mailing

On or about March 18, 2014 the customer mailing will take place. A sample copy of the owner letter is enclosed.

Service Action Expiration Date

- This service action will be available for customers free of charge **only until March 31, 2016**. Vehicles repaired under this action must have this service completed on or before **March 31, 2016** to be eligible for payment.
- **Inspections/repairs performed after March 31, 2016 will not be eligible for payment.** Dealers should keep this expiration date in mind when scheduling customers for this action.
- If a customer wishes to have this service performed after the expiration date, your dealerships normal parts and labor cost associated with this repair will apply.

Campaign Completion Labeling Guidelines

Vehicles repaired under this action must be identified with a campaign completion label (part number CAMP 010 000). Labels can be ordered at no cost online via the Compliance Label Ordering portal at www.vw.com.

Claim Entry Procedure

Immediately upon completion of the repair work, enter the Applicable Criteria ID and Repair Operation from the following chart. **The Applicable Criteria ID is shown in Elsa.** Claims will only be paid for vehicles that show this campaign open in Elsa on the day of the repair. To help ensure prompt and proper payment, attach the screen print to the repair order.

Saga Claim Entry Procedure

Check Elsa to determine if this campaign is open.

Service No.: 19J5
Damage Code: 0099

Parts Manufacturer

Removed part: Use vendor code **WWO**

Sold vehicle = 7 10

Unsold vehicle = 7 90

Accounting Instructions

Criteria 01 – Replace coolant pump.

Repair operation: 1950 55 99 285 T.U.

<u>Quantity</u>	<u>Part Number</u>	<u>Part Description</u>
1	06F121011	Coolant pump *
2	N10552402	Upper Engine Mount Bolt
1	N91029602	Upper Engine Mount Bolt
2	N01950213	Upper Engine Mount Bolt
1	N90596906	Upper Engine Mount Bolt
1	N91167101	Lower Engine Mount Bolt
1	N91066101	Lower Engine Mount Bolt
1	N10558002	Lower Engine Mount Bolt
1	G013A8J1G	G13 Coolant – 1 Gallon Concentrate
6	N91143901	M8x16 Vibration Damper Bolt
1	3C0131483	Clamp

***Causal Indicator: Select coolant pump as causal part**

There is NO reimbursement for Vehicle Wash or Loaner

If customer refused repairs

U.S. dealers: Submit the request through WISE under the Campaigns/Update/Recall Closure option.

Canadian dealers: Fax the Repair Order to Warranty at (905) 428-4811 and provide VIN, applicable Service Number, Customer Information, Dealer Number and Date.

The repair information in this document is intended for use only by skilled technicians who have the proper tools, equipment and training to correctly and safely maintain your vehicle. These procedures are not intended to be attempted by "do-it-yourselfers," and you should not assume this document applies to your vehicle, or that your vehicle has the condition described. To determine whether this information applies, contact an authorized Volkswagen dealer. ©2014 Volkswagen Group of America, Inc. and Volkswagen Canada. All Rights Reserved.

Customer Letter Example (USA)

<MONTH YEAR>

<CUSTOMER NAME>

<CUSTOMER ADDRESS>

<CUSTOMER CITY STATE ZIPCODE>

This notice applies to your vehicle: <VIN>

**Subject: Service Action 19J5
2012-2013 Model Year Golf R
Coolant Pump**

Dear Volkswagen Owner,

As part of Volkswagen's ongoing commitment to customer satisfaction, we are informing you of our decision to conduct a service action on some 2012-2013 model year Golf R vehicles. Our records show that you are the owner of a vehicle affected by this action.

What is the issue? Some customers have reported engine compartment noise and hard start issues with their vehicles. Volkswagen has determined that the coolant pump is the source of these concerns.

What will we do? Your authorized Volkswagen dealer will replace the coolant pump in your vehicle. This work will take about three hours to complete and will be performed for you free of charge. Please note that this repair will be available for you free of charge only until March 31, 2016. After that, any remaining applicable warranty will apply.

IMPORTANT!

This repair affects the engine/engine compartment of your vehicle. If aftermarket modifications to these areas are present, they must be addressed at customer responsibility before this service action can be performed.

What should you do? In order to limit any possible inconvenience, please contact your authorized Volkswagen dealer as soon as possible to schedule this service. Please keep in mind that your dealer may need additional time for the preparation of the repair, as well as to accommodate their daily workshop schedule.

Lease vehicles and address changes If you are the lessor and registered owner of the vehicle identified in this action, please forward this letter immediately via first-class mail to the lessee within ten (10) days of receipt. If you have changed your address or sold the vehicle, please fill out the enclosed prepaid Owner Reply card and mail it to us so we can update our records.

Reimbursement of Expenses If you have previously paid for repairs relating to the condition described in this letter, the enclosed form explains how to request reimbursement. We would be pleased to review your reimbursement request.

Can we assist you further? If your authorized Volkswagen dealer fails or is unable to complete this work free of charge within a reasonable time, please call or write to:

Volkswagen of America, Inc.,
Attn: Customer CARE (19J5/5V)
3800 Hamlin Road, Auburn Hills, MI 48326
1-800-893-5298
www.vw.com

We apologize for any inconvenience this matter may cause; however we are taking this action to help ensure your vehicle continues to meet and exceed your expectations. Thank you for driving a Volkswagen!

Sincerely,

Volkswagen Service & Quality

Customer Letter Example (CANADA)

<MONTH YEAR>

<CUSTOMER NAME>

<CUSTOMER ADDRESS>

<CUSTOMER CITY STATE ZIPCODE>

This notice applies to your vehicle: <VIN>

**Subject: Service Action 19J5
2012 Model Year Golf R
Coolant Pump**

Dear Volkswagen Owner,

As part of Volkswagen's ongoing commitment to customer satisfaction, we are informing you of our decision to conduct a service action on some 2012 model year Golf R vehicles. Our records show that you are the owner of a vehicle affected by this action.

What is the issue? Some customers have reported engine compartment noise and hard start issues with their vehicles. Volkswagen has determined that the coolant pump is the source of these concerns.

What will we do? Your authorized Volkswagen dealer will replace the coolant pump in your vehicle. This work will take about three hours to complete and will be performed for you free of charge. Please note that this repair will be available for you free of charge only until March 31, 2016. After that, any remaining applicable warranty will apply.

IMPORTANT!

This repair affects the engine/engine compartment of your vehicle. If aftermarket modifications to these areas are present, they must be addressed at customer responsibility before this service action can be performed.

What should you do? In order to limit any possible inconvenience, please contact your authorized Volkswagen dealer as soon as possible to schedule this service. Please keep in mind that your dealer may need additional time for the preparation of the repair, as well as to accommodate their daily workshop schedule.

Lease vehicles and address changes If you are the lessor and registered owner of the vehicle identified in this action, please forward this letter immediately via first-class mail to the lessee within ten (10) days of receipt. If you have changed your address or sold the vehicle, please fill out the enclosed prepaid Owner Reply card and mail it to us so we can update our records.

Reimbursement of Expenses If you have previously paid for repairs relating to the condition described in this letter, the enclosed form explains how to request reimbursement. We would be pleased to review your reimbursement request.

Can we assist you further? If your authorized Volkswagen dealer fails or is unable to complete this work free of charge within a reasonable time, please call or write to:

Volkswagen Canada
Attn: Customer Relations (19J5/5V)
PO Box 842, Stn. A
Windsor, ON N9A 6P2
1-800-822-8987
www.vw.ca

We apologize for any inconvenience this matter may cause; however we are taking this action to help ensure your vehicle continues to meet and exceed your expectations. Thank you for driving a Volkswagen!

Sincerely,

Volkswagen Service & Quality

If there are questions regarding the work procedure:

- U.S. dealers, contact Warranty
- Canadian dealers, open an VTA ticket using concern group “Compliance_Recall Assistance (C)”

Required Tools:

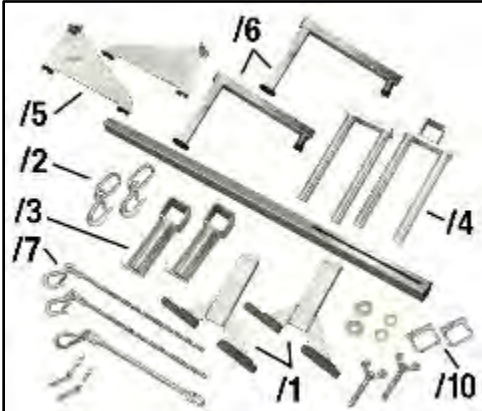

- 10-222A – Engine Support Bridge

⚠ Note: Contains sub components as follows:
1,/2,/3,/4,/5,/6,/7,/8,/11,/017(holder), /021 (long rod), /022 (spindle), / 24 (screw for bracket), /025 (bracket), /27.



- 10-222A/3 – Engine Support 3



- 10-222A/8 – Engine Support Feet



- T10339 – Engine Support Bracket



- 10-222A/10 – Bracket with Spindle and Hook



- 10-222A/18 – Engine Support 18



- T10346 – Gearbox Bracket



- VAS6096 – Cooling System Charge Kit



- VAG 1274/8 – Cooling System Tester Adapter



- T10007A – Refractometer



- VAS6340 – Hose Clip Pliers



- VAG1331 – Torque Wrench 1331 5-50Nm (or equivalent)



- VAG1783 – Torque Wrench 1783 2-10Nm (or equivalent)

Required Parts:

<u>Quantity</u>	<u>Part Number</u>	<u>Part Description</u>
1	06F121011	Coolant pump
2	N10552402	Upper Engine Mount Bolt
1	N91029602	Upper Engine Mount Bolt
2	N01950213	Upper Engine Mount Bolt
1	N90596906	Upper Engine Mount Bolt
1	N91167101	Lower Engine Mount Bolt
1	N91066101	Lower Engine Mount Bolt
1	N10558002	Lower Engine Mount Bolt
1	G013A8J1G	G13 Coolant – 1 Gallon Concentrate
6	N91143901	M8x16 Vibration Damper Bolt

Work Procedure



Tip: If Campaign Completion label is present, no further work is required

Applicable Criteria ID (s)	Campaign/Action Status
01	Open

EXAMPLE

Section A – Check for Previous Repair

- Enter the VIN in Elsa and proceed to the “Campaign/Action” screen



Tip: On the date of repair, print this screen and keep a copy with the repair order

- ⇐ Ensure that the Status is “Open”
<arrow 2>
- ⇐ Note the Applicable Criteria ID
<arrow 1> for use in determining the correct work to be done and corresponding parts associated

- **Proceed to Section B.**

Section B - Disassembly



Tip: Due to the extensive nature of the repair, please read this entire procedure prior to beginning work on the vehicle.



Note: This repair affects the engine/engine compartment of the vehicle. If aftermarket modifications to these areas are present, they must be addressed as customer responsibility before this service action can be performed.

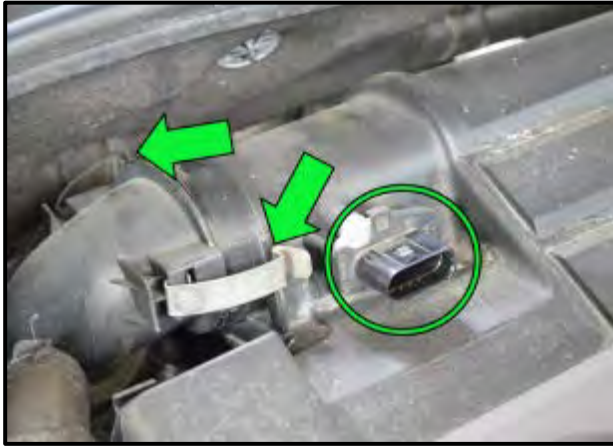

- Open the hood.
- ⇐ Disconnect the Mass Airflow Sensor (MAF) electrical connector <circle>.
- ⇐ Unfasten the retaining clips between the MAF and the turbo inlet pipe <arrows>.
- Disconnect the turbo inlet pipe from the MAF.



Note: Use caution when disconnecting the turbo inlet pipe from the MAF. The opposite end of the pipe is clamped onto the turbo assembly. Damage to the turbo inlet pipe is not covered under this action.

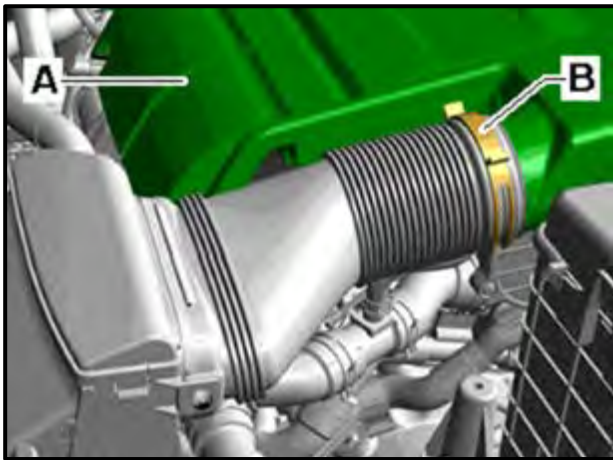

- ⇐ Release the clamp using the **hose clip pliers VAS 6340** (or equivalent).
- ⇐ Remove the intake air duct from the engine cover <A>.

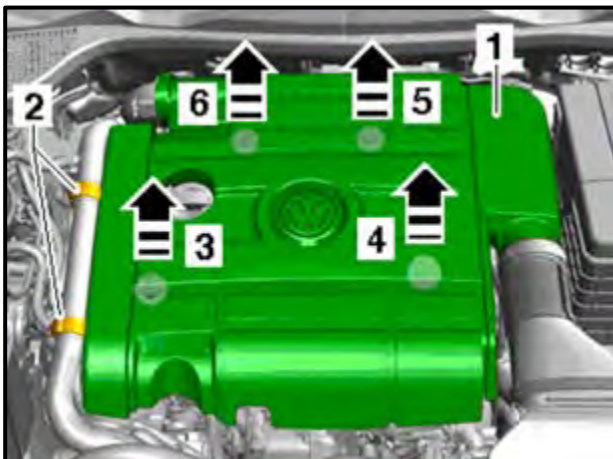

- ⇐ Unclip the hose from the mounts <2>.
- Remove the oil fill cap.
- ⇐ Lift the engine cover in the direction of the arrows <3, 4, 5, and 6> one after the other and lift the engine cover off.
- Reinstall the oil fill cap.



Note: Use caution when removing the engine cover. Damage to the engine cover is not covered under this action.



- Remove the battery cover.
- Remove both cables from the battery.
- ⇐ Remove the battery mounting bolt and retaining bracket <circle>.
- Remove the vehicle battery.



- ⇐ Remove the three mounting bolts from the battery tray <circles>.
- Remove the battery tray.



- ⇐ Fasten the **T10346 gearbox bracket** to the rear battery tray mounting flange using the rear battery tray retaining bolt as shown <circle>.

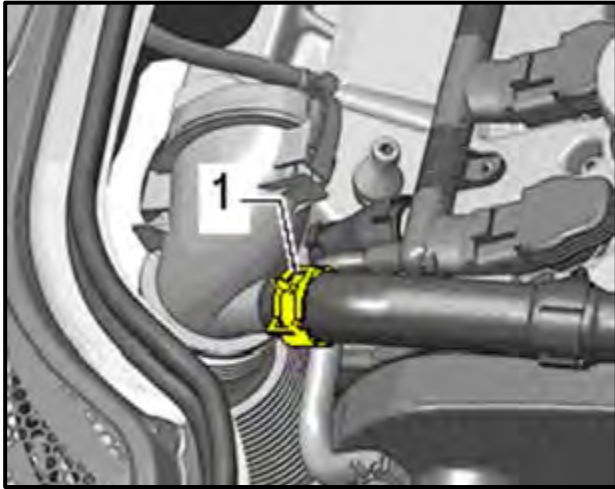

- ⇐ Release the clamp <1> using **hose clip pliers VAS6340** (or equivalent).
- Remove the recirculation hose from the turbo inlet pipe.
- Reposition the recirculation hose to provide access to the timing cover area.

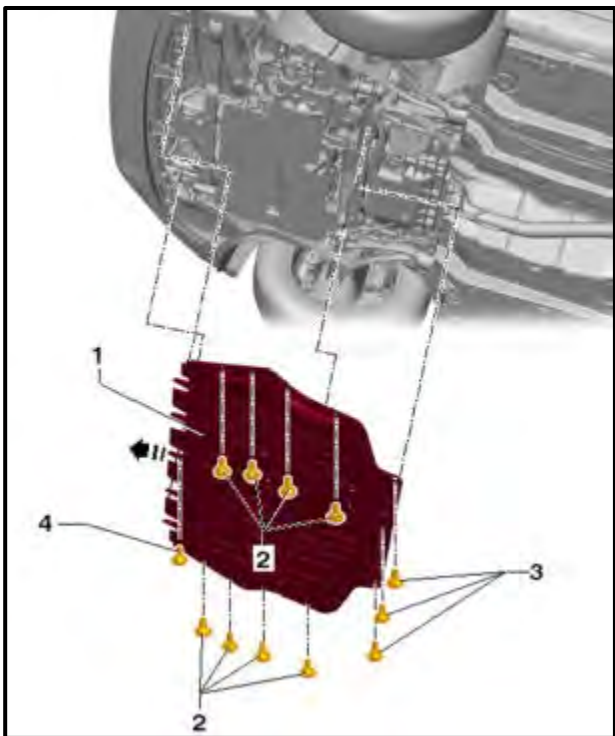

- Remove the coolant expansion tank fill cap.

! **WARNING:** The cooling system may be hot, and/or under pressure. Use caution when opening any cooling system.

- Raise the vehicle on an appropriate hoist.
- ⇐ Remove the underbody shield mounting bolts <2, 3, and 4>.
- Remove the underbody shield from the vehicle.

! **Note:** Damage to the underbody shield is not covered under this action.

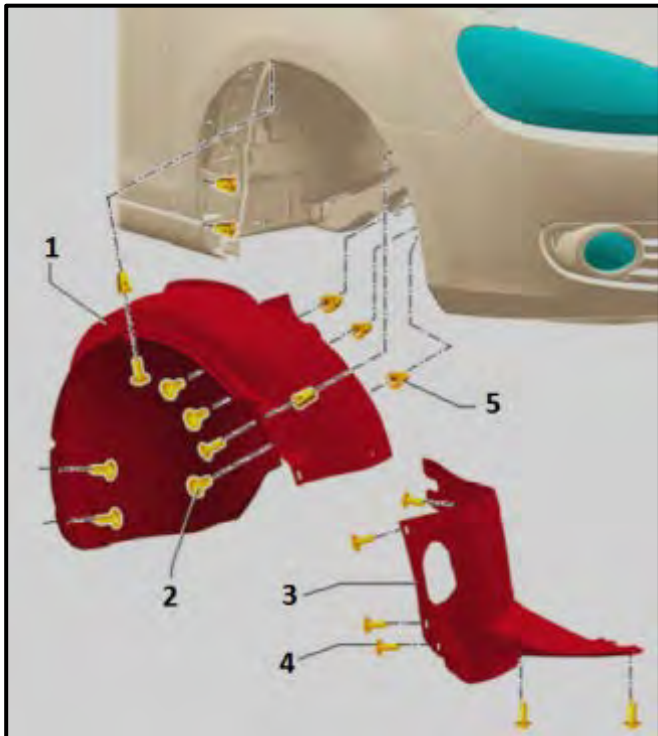

- Remove the right front wheel.
- ⇐ Remove the mounting bolts and retaining clips for the right front wheel housing liner <2 and 4>.
- Remove the right front wheel housing liner from the vehicle.

⚠ Note: Damage to the wheel housing liner is not covered under this action.

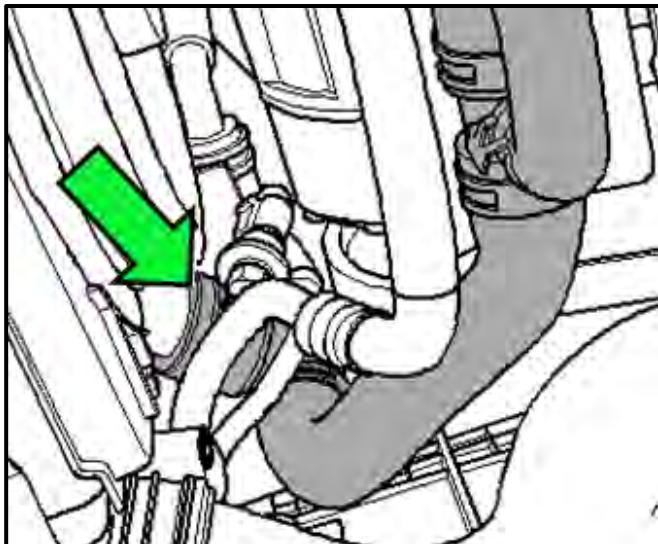

- Position an appropriate drain pan under the vehicle.
- ⇐ Release the quick release coupling on the lower radiator hose as shown <arrow>.
- Disconnect the lower radiator hose and drain the cooling system.

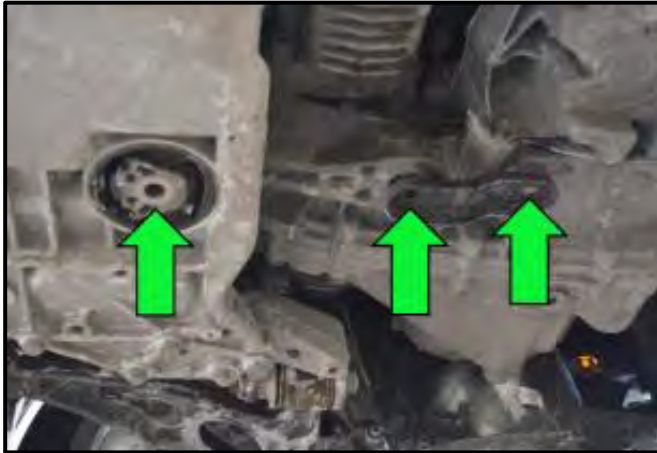

- Remove and discard the mounting bolts for the lower engine mount where shown <arrows>.
- Remove the lower engine mount.



Note: The bolts removed from the engine mounts during this repair must be discarded. New bolts must be used when reinstalling the engine mount.

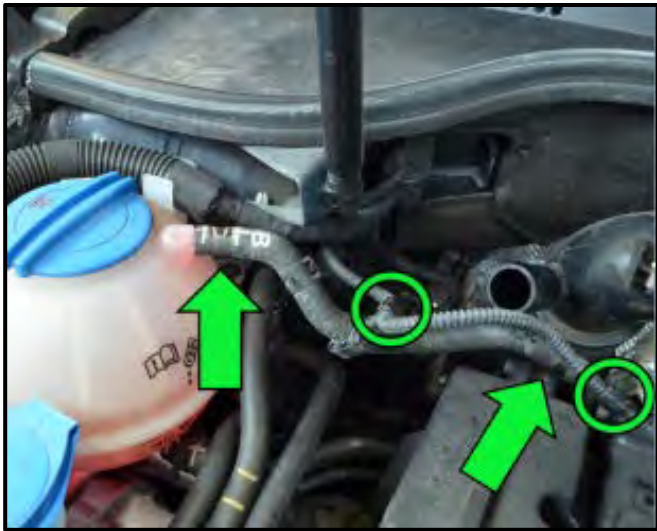

- ⇐ Release the retaining clips <circles> and detach the wiring loom from the coolant hose.
- ⇐ Release the clamps <arrows> and remove the coolant hose from the vehicle.



- ⇐ Disconnect the fuel supply line and evaporative emission hoses <arrows>.
- Reposition the hoses to provide access to the timing cover area.

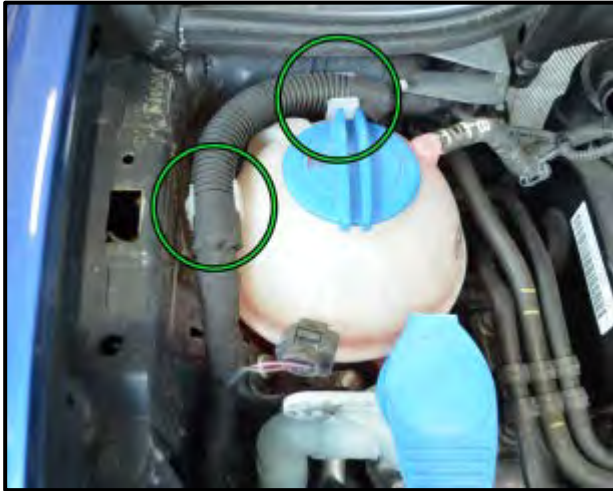

- ⇐ Remove the wiring harness from the clips on the coolant expansion tank <circles> to allow for removal of the reservoir.

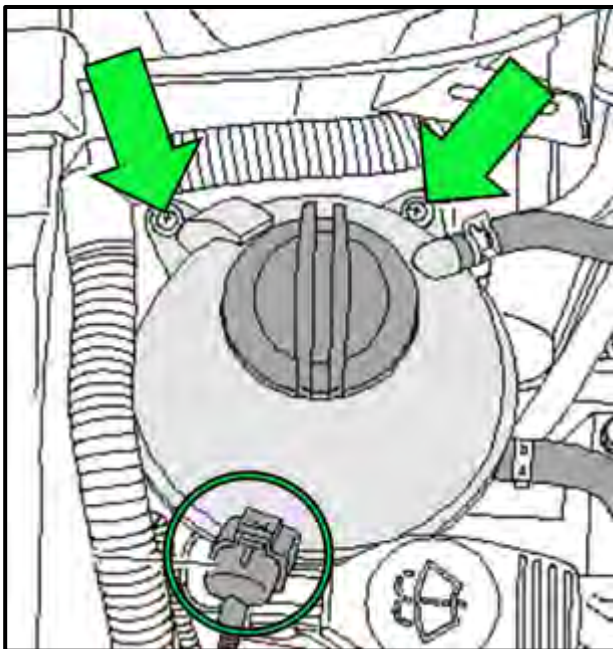

- ⇐ Remove the mounting screws from the coolant expansion tank <arrows>.
- ⇐ Disconnect the coolant level sensor electrical connector <circle> from the coolant expansion tank.
- Remove the coolant expansion tank.



Tip: The coolant expansion tank does not need to be completely removed from the vehicle. The lower hose can remain attached, and the reservoir can be set aside to allow access to the timing belt area.



- ⇐ Release the clamp <circle> on the turbo coolant hose.
- Disconnect and reposition the turbo coolant hose to provide access to the timing cover area.

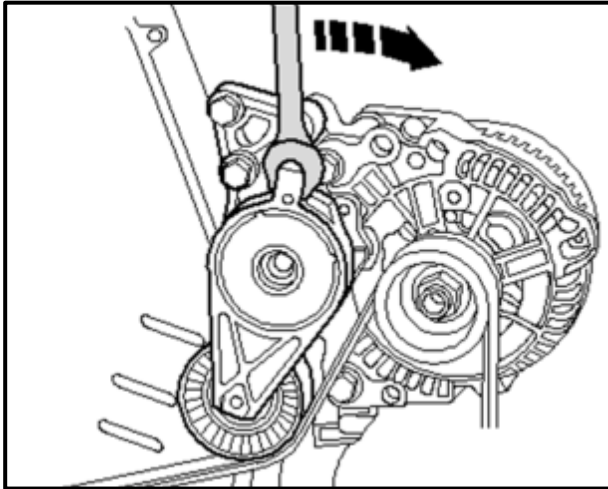

- Mark the direction of travel on the serpentine belt.
- ⇐ Rotate the serpentine belt tensioner forward as shown <arrow> to release the belt.
- Remove the serpentine belt.
- Loosen the three mounting bolts for the serpentine belt tensioner and remove the tensioner from the vehicle.

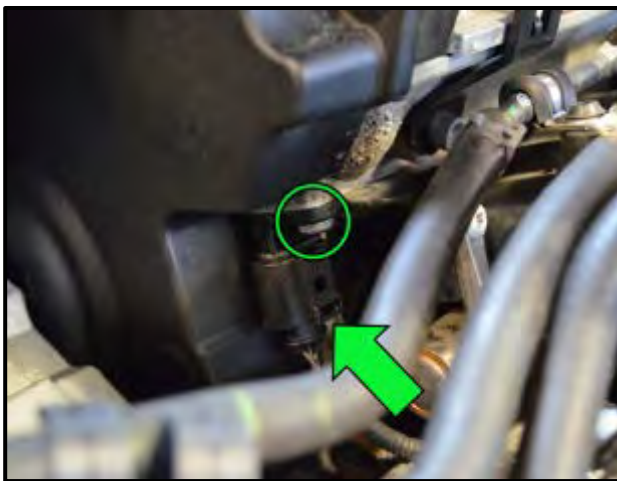

- ⇐ Disconnect the electrical connector from the camshaft position sensor <arrow>.
- ⇐ Remove the mounting screw <circle> and the camshaft position sensor.



- ⇐ Remove the mounting bolts from the upper timing cover <arrows>.
- Remove the upper timing cover.



i Tip: Read the next several steps pertaining to the engine support bridge assembly and use prior to installing it onto the vehicle. The final assembly is pictured here <left>.



← Install **T10339 engine support bracket** in place of the serpentine belt tensioner as shown <arrow>.

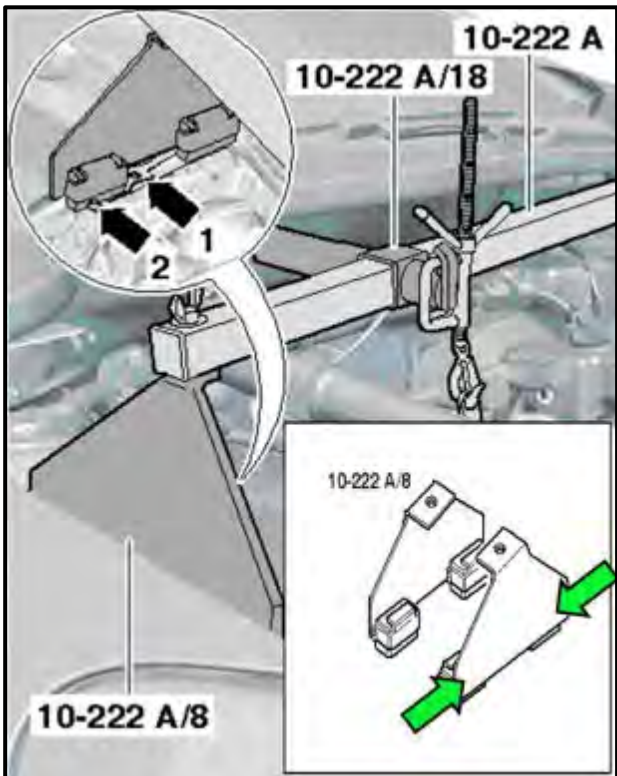

- Install the **engine support bridge 10-222A** with the **engine support feet 10-222A/8** and the **adapters 10-222A/18 and 10-222A/3** onto the longitudinal member as shown.

i Tip: The long arm of the adapter should extend toward the rear of the engine compartment when installed.

i Tip: Apply a felt tape or other insulating material to the area shown <arrows> on the **10-222 A/8 support feet** to avoid damaging painted surfaces on the fenders.

i Tip: **Adapter 10-222A/18** will be positioned over the serpentine belt area, and **adapter 10-222A/3** will be positioned over the battery tray area when complete.



- Position the **adapter 10-222A/3** directly above the battery tray as shown.
- Install the **10-222A/10 spindle bracket and hook** onto the **adapter 10-222A/3** as shown.



Tip: The arm of the adapter should extend toward the rear of the engine compartment when installed.

- ← Attach the **10-222A/10 spindle bracket and hook** <arrow> to the **T10346 bracket** that was installed previously <circle>.

- Tighten both the left and right side adjusters to stabilize the engine support bridge and remove the load from the upper engine mount.

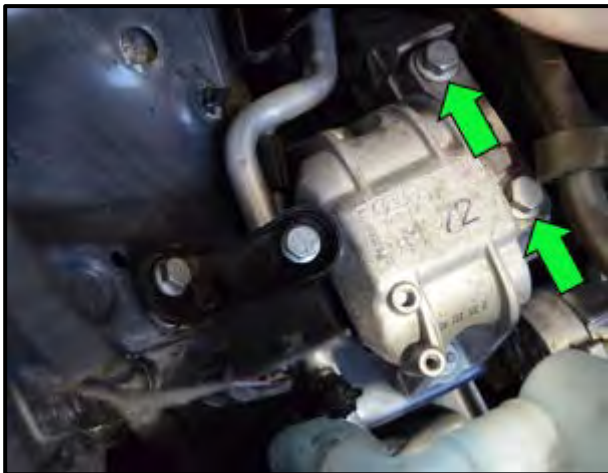

- ← Remove and discard the two engine mount bolts <arrows>.

- Adjust and stabilize the engine support bridge as necessary.



Note: The bolts removed from the engine mounts during this repair must be discarded. New bolts must be used when reinstalling the engine mount.



Tip: The engine support bracket **must** be adjusted to remove any weight from the engine mount itself before the remaining engine mount bolts can be removed.

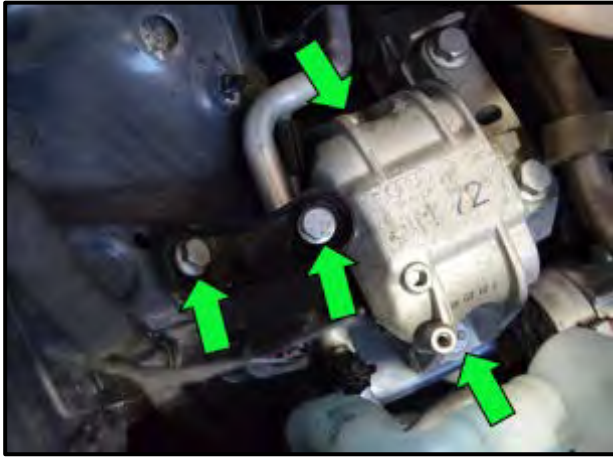

⇐ Remove and discard the remaining four engine mount bolts <arrows>.

- Remove the upper engine mount.



Note: While adjusting the engine support bridge, monitor the clearance between engine components and the master cylinder <circle>. Various lines, wiring harness segments, and other components can be damaged if pinched or stretched when raising or lowering the engine.

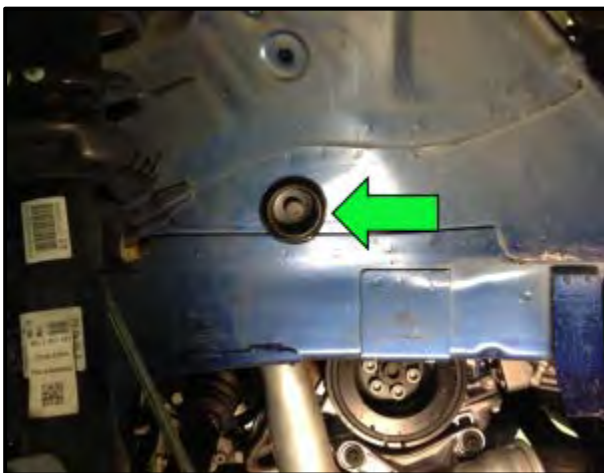

- Remove the plug from the inner fender to access one of the engine mount bracket bolts <arrow>.

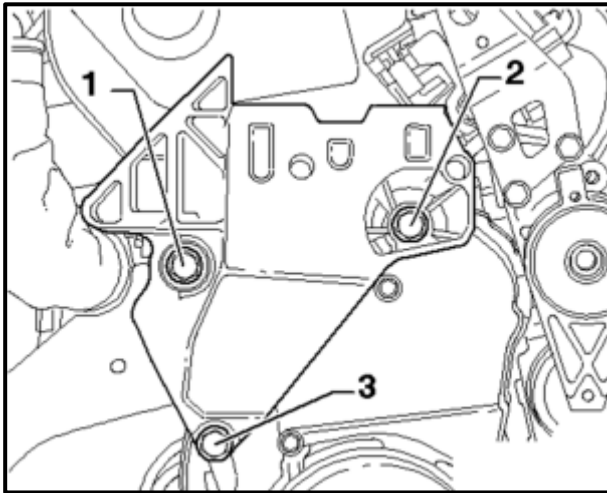

⇐ Using the access hole in the inner fender, remove the rear engine mount bracket bolt <1>.

- Raise the engine as far as possible without damaging surrounding lines, wiring, or other components.

⇐ Remove the top right engine mount bracket bolt <2>.

- Lower the engine as far as possible without damaging surrounding lines, wiring, or other components.

⇐ Remove the bottom engine mount bracket bolt <3>.



Tip: The engine mount bracket itself cannot be removed at this time. Remove only the mounting bolts, then proceed to the next step.

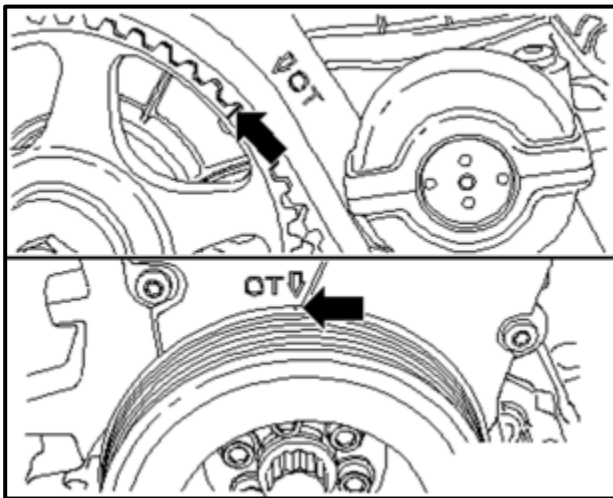

- Raise the engine to an appropriate level.

⇐ Rotate the crankshaft by hand in a clockwise direction until the timing marks are aligned as shown <arrows>.

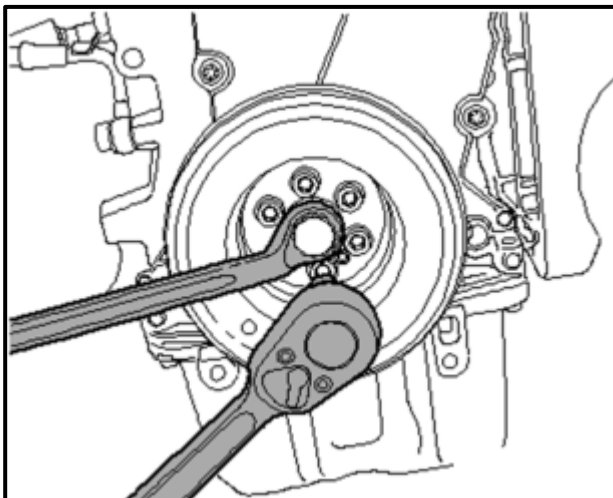

⇐ Hold the center crankshaft bolt stationary as shown and remove the 6 retaining bolts for the vibration damper.

- Remove the vibration damper.





Note: To prevent engine damage, the timing marks must be lined up before removing the vibration damper.



⇐ Remove the retaining bolts from the lower timing cover <arrows>.

- Remove the lower timing cover.
- Remove the engine mount bracket.

 Tip: The lower timing cover **MUST** be removed prior to removing the engine mount bracket.

 Note: Prior to removal, the timing belt must be marked to indicate the direction of travel. Installing the timing belt in the wrong direction of travel will cause premature failure. Timing belt replacement is not covered under this action.



- Raise the engine as far as possible without damaging surrounding lines, wiring, or other components.
- Verify the camshaft timing mark is still lined up correctly.
- Rotate the crankshaft if necessary to realign the timing mark properly.
- Mark the timing belt to indicate the direction of travel.

⇐ Loosen the timing tensioner nut <circle>.

- Insert an allen wrench where shown <arrow>. Release the timing belt tension by rotating the tensioner in a counter-clockwise direction.
- Remove the timing belt.

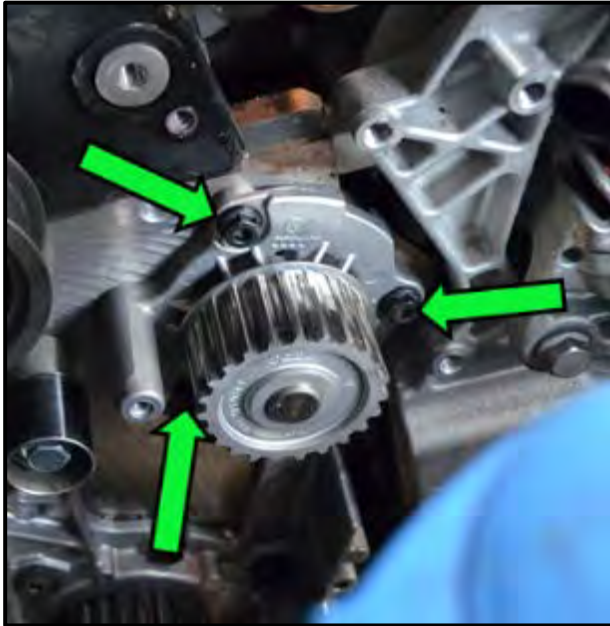

- ⇐ Remove the three retaining bolts from the coolant pump <arrows>.
- Remove the coolant pump.

Proceed to Section C – Coolant Pump Installation and Reassembly

Fastener Size	Nm
M6	10
M7	15
M8	25
M10	40
M12	60

Section C – Coolant Pump Installation Reassembly

! Note: During reassembly, all fasteners must be properly torqued. Torque specifications for major components are called out in this circular. For the torque specifications on all remaining fasteners, refer to the appropriate section in Elsa, or to the chart on the left.

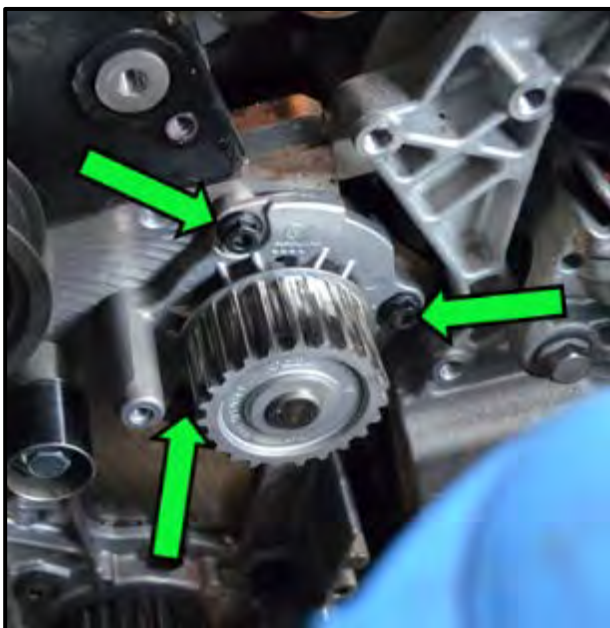

- Lubricate the seal on the replacement coolant pump with clean coolant.
- Install the replacement coolant pump.
- ⇐ Install and torque the three coolant pump mounting bolts to **15Nm** <arrows>.
- Use clean water to rinse the timing belt area and remove any residual coolant.

! Note: The timing belt area **MUST** be cleaned of any residual coolant prior to installing the timing belt.

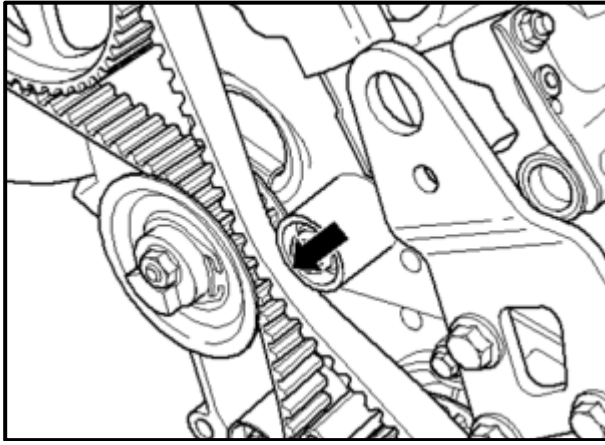

- Inspect the camshaft timing mark. Verify the mark is still properly aligned, and adjust as necessary.
- Reinstall the timing belt.



Note: Route the timing belt **in this order**: under the crankshaft pulley, over the tensioner, around the camshaft sprocket, over the coolant pump, then under the idler pulley <arrow>.

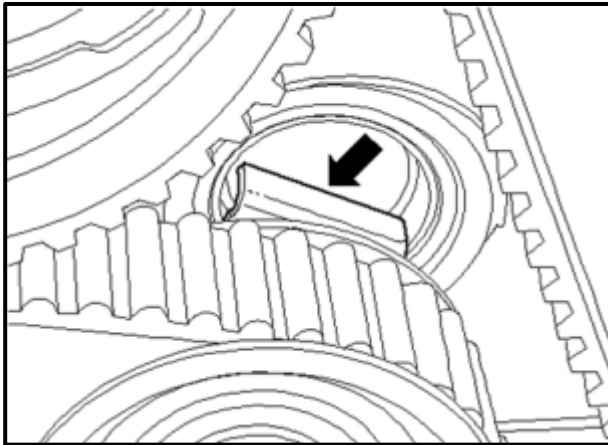

- ⇐ During timing belt installation and tensioner adjustment, verify the timing belt tensioner is seated into the cylinder head as shown <arrow>.

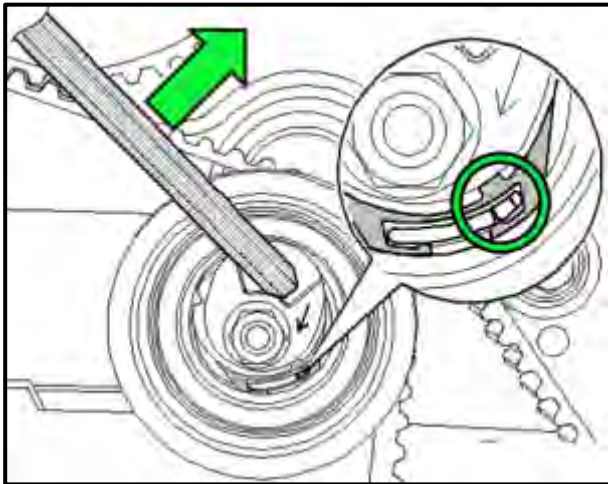

- ⇐ Tension the timing belt by turning the tensioner with an allen wrench in a clockwise direction <arrow>.
- ⇐ The belt is properly tensioned when the notch and tab line up as shown <circle>.
- Tighten the tensioner retaining nut to **25Nm**.
- Using the appropriate wrench, rotate the crankshaft by hand two full revolutions in a clockwise direction.
- Recheck the timing marks. If the marks do not line up properly, loosen the tensioner and repeat the timing belt installation steps.



Note: The timing marks on the crankshaft and camshaft pulleys **MUST** line up prior to proceeding with the rest of this procedure. Failure to properly align the marks will result in engine damage. Damage to the engine is not covered under this action.



⇐ Loosely reinstall the upper engine mount bracket <left>.



Tip: Due to space constraints, do not install the mounting bolts at this time.

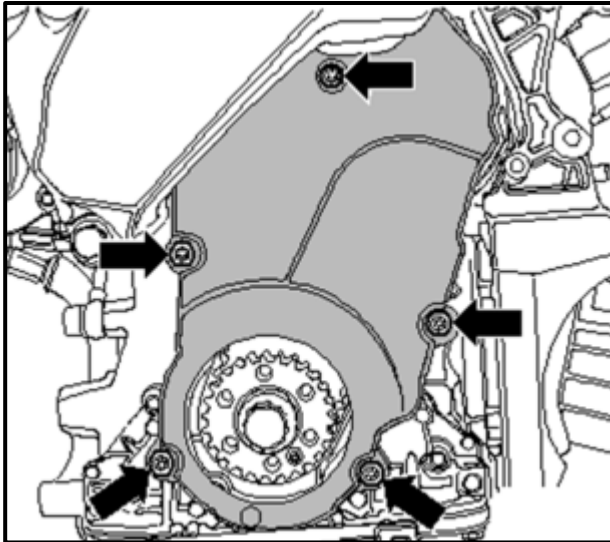

- Reinstall the lower timing cover.
- ⇐ Reinstall and torque the timing cover bolts <arrows> to **10Nm**.
- Reinstall the vibration damper.
 - Install new vibration damper mounting bolts p/n N911473901 and torque to **20Nm plus an additional ¼ turn**.



Tip: Use a medium strength thread locking compound on all timing cover bolts, as well as on the vibration damper bolts (shop supply).



- Reinstall the upper timing cover.
- ⇐ Install and torque the mounting bolts to **10Nm** <arrows>.



Tip: Use a medium strength thread locking compound on all timing cover bolts, as well as on the vibration damper bolts (shop supply).

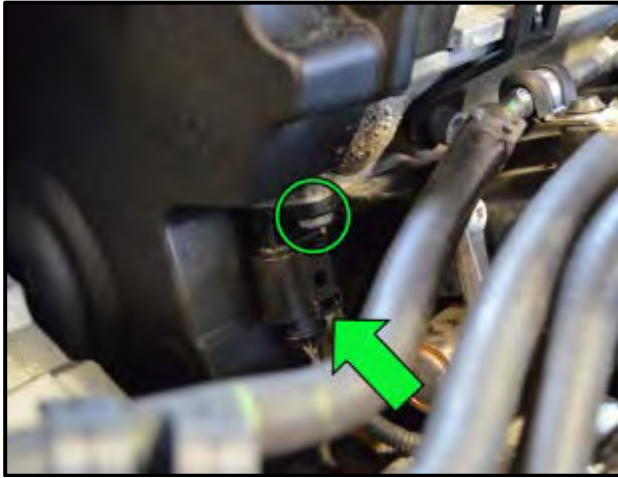

- ⇐ Reinstall the camshaft position sensor and tighten the mounting screw <circle>.
- ⇐ Reconnect the electrical connector <arrow>.

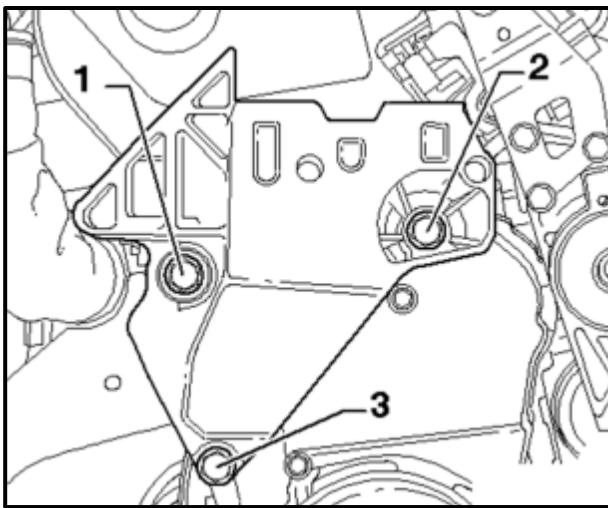

- ⇐ Install the top engine mount bracket bolts <1 and 2>.
- Lower the engine as far as possible without damaging surrounding lines, wiring, or other components.
- ⇐ Install the lower engine mount bracket bolt <3>.
- Torque all three engine bracket mounting bolts to **45Nm**.

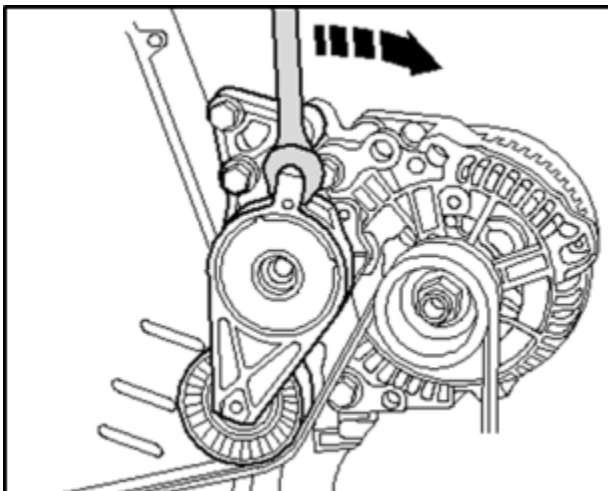

- Reinstall the serpentine belt tensioner and tighten the three mounting bolts.
- ⇐ Rotate the tensioner forward as shown <arrow> to allow for belt installation. Install the serpentine belt.

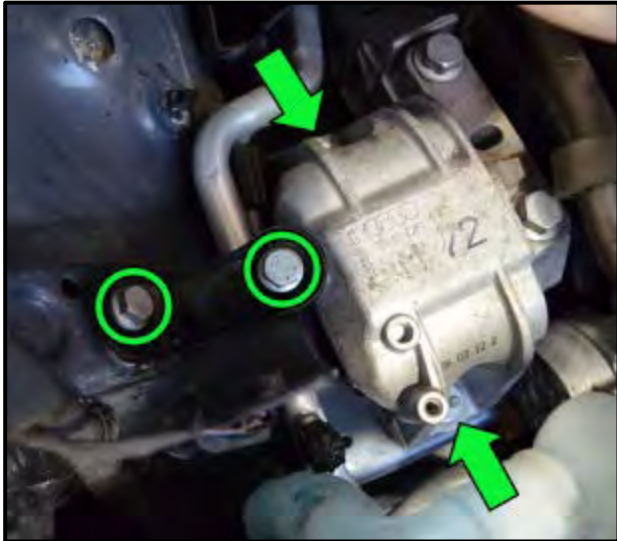

- Reinstall the upper engine mount.
- Install new retaining bolts, p/n N91029602, N01950213 (x2), and N90596906, between the engine mount and the vehicle body as shown.

- ⇐ Torque the lower bolts <arrows> to **40Nm plus an additional ¼ turn.**
- ⇐ Torque the upper bolts <circles> to **20Nm plus an additional ¼ turn.**

⚠ Note: Engine mount bolts are not reusable and must be replaced during reassembly.

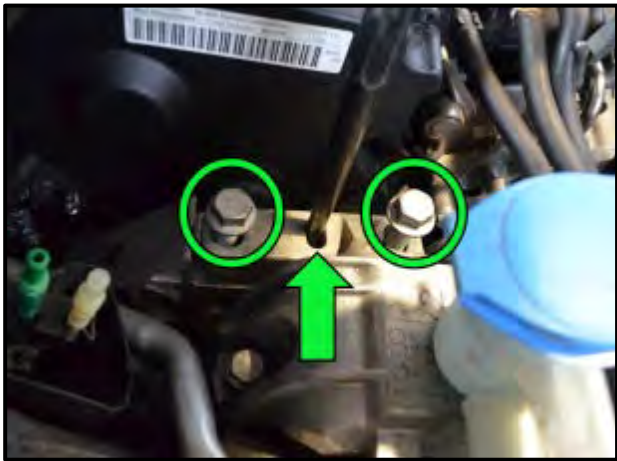

- ⇐ Insert a tapered punch (or equivalent) into the center alignment hole <arrow> on the engine mount.
- Carefully raise the engine into place by adjusting the **10-222A/10 spindle bracket and hook**. Align the engine mount using the tapered punch.

- ⇐ Install new engine mount bolts, p/n N10552402 <circles> and torque to **60Nm plus an additional ¼ turn.** Disassemble and remove the **engine support bridge 10-222A** and all the associated brackets and fittings.

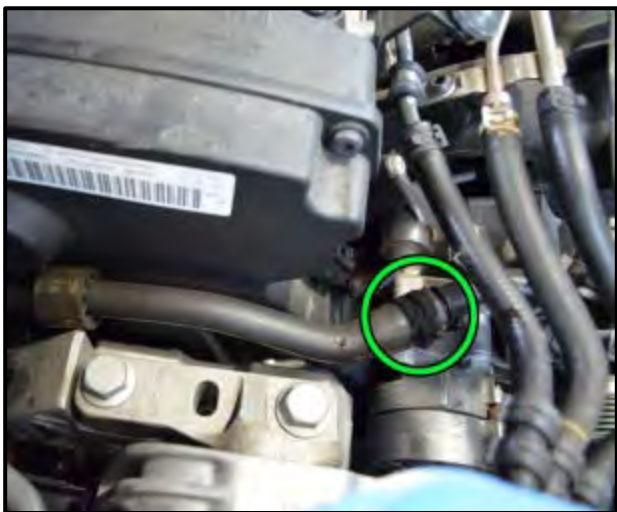

- Reconnect the coolant hose between the turbo and the metal pipe as shown.
- ⇐ Refasten the clamp <circle>.

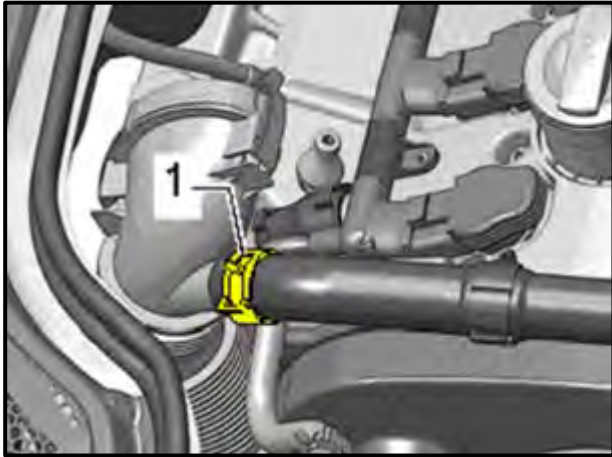

- Reinstall the turbo recirculation hose as onto the turbo inlet pipe as shown and reposition the retaining clamp <1>.

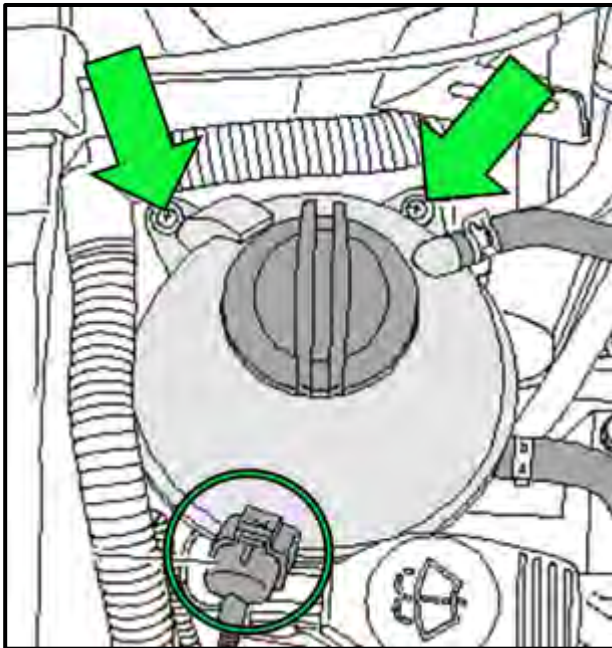

- ⇐ Reinstall the coolant expansion tank and tighten the mounting screws <arrows>.
- ⇐ Reinstall the electrical connector <circle>.

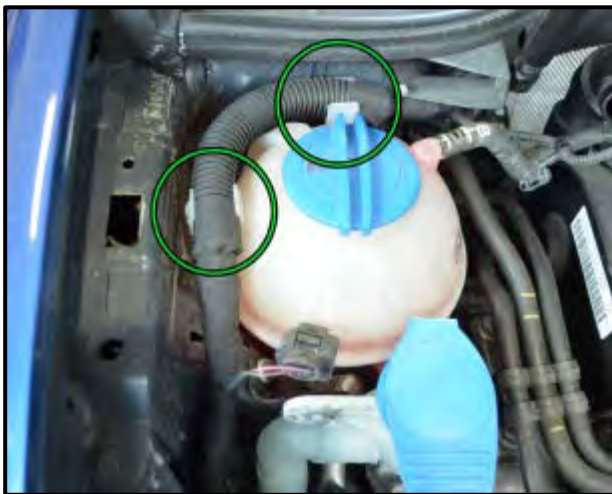

- ⇐ Secure the wiring harness into the retaining clips as shown <circles>.



⇐ Reattach the fuel and evaporative emission hose connections <arrows>.

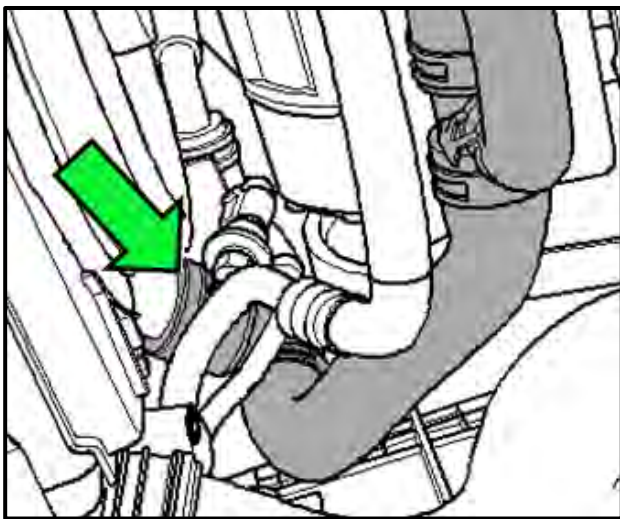

- Reconnect the lower radiator hose.

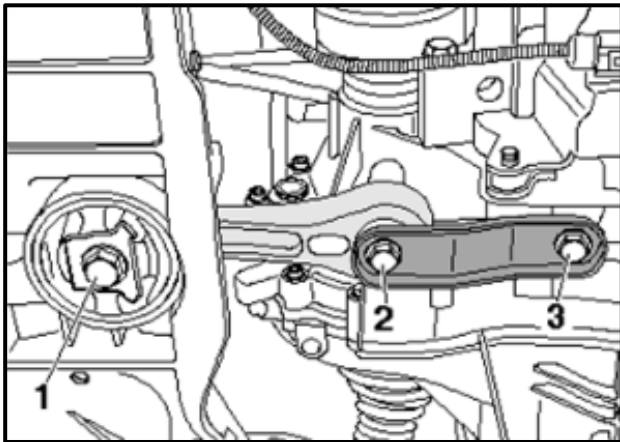

- Reinstall the lower engine mount.
- Install new engine mounting bolts p/n N91167101, N91066101, and N10558002.

⇐ Torque mounting bolt <1> to **100Nm plus an additional ¼ turn**.

⇐ Torque mounting bolts <2 and 3> to:

- **40Nm plus an additional ¼ turn** if replacement bolt is **grade 8.8**.
- OR-**
- **50Nm plus an additional ¼ turn** if replacement bolt is **grade 10.9**.

⚠ Note: Engine mount bolts are not reusable and must be replaced during reassembly.

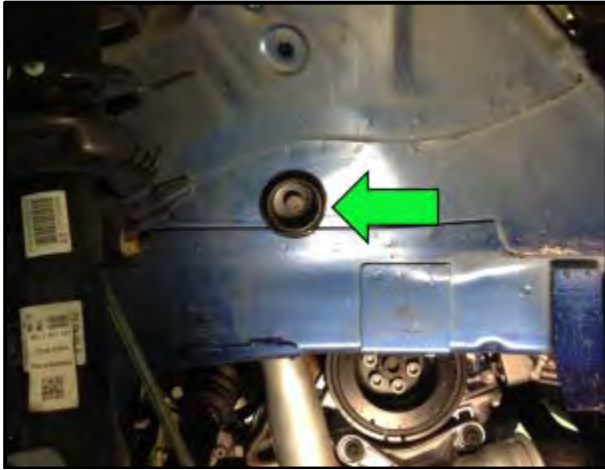

⇐ Reinstall the plug in right front inner fender <arrow>.

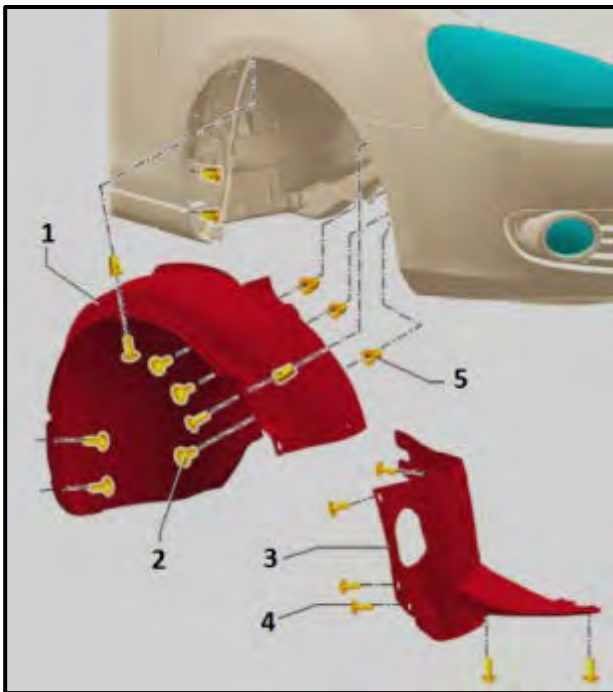

- Reinstall the right front wheel housing liner.

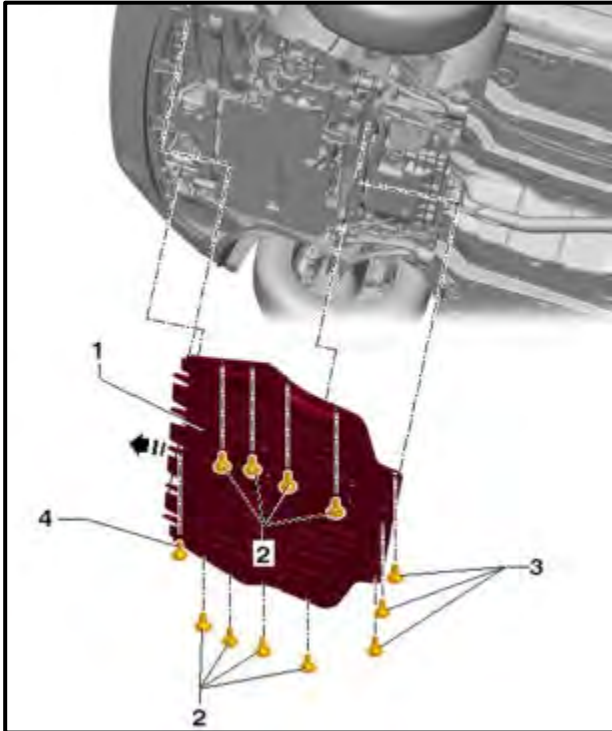

- Reinstall the underbody shield.



- Reinstall the right front wheel.
- Torque the wheel mounting bolts to **120Nm**.

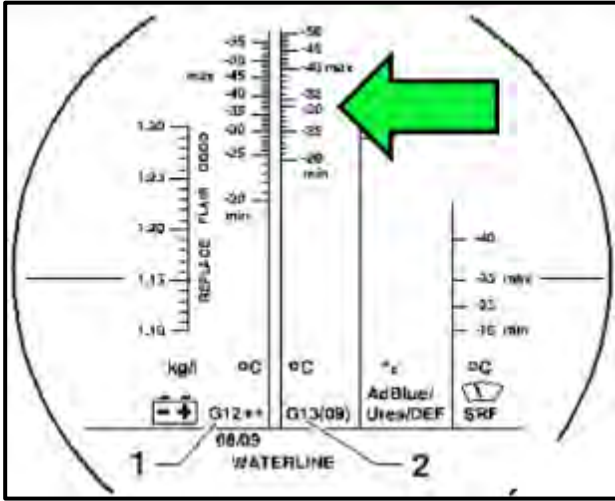

- Mix one gallon of G13 coolant with one gallon of distilled water, then fill the VAS6096 reservoir.
 - Use the refractometer T10007A to measure the freeze protection density of the coolant and adjust as necessary.
- ⇐ Properly mixed coolant (50/50 ratio with distilled water) will read at least -30°C <arrow>.

! Note: The coolant freeze protection density should be adjusted according to the surrounding climate. Colder climates will require a lower freeze protection density.



- ⇐ Attach the adapter VAG 1274/8 onto the coolant expansion tank as shown <arrow>.
- Attach the cooling system filler unit VAS6096 to the adapter VAG 1274/8.
 - Remove the VAS 6096 tool and VAG 1274/8 adapter.
 - Install the coolant expansion tank cap.

i Tip: Refer to the cooling system filler unit VAS6096 operating instructions if necessary.



- Reinstall the battery tray.
- ⇐ Tighten the mounting bolts <circles>.



- Reinstall the vehicle battery.
- ⇐ Install and tighten the battery retaining bolt and bracket <circle>.
- Reattach and tighten both battery cables.
- Reinstall the battery cover.

- Start the engine, and allow it to idle for 5-10 minutes.
- Inspect the cooling system for any leaks.
- Shut the engine off.
- Carefully remove the cap from the coolant expansion tank.



WARNING: The cooling system may be hot, and/or under pressure. Use Note when opening any cooling system.

- Recheck the coolant freeze protection density using the T10007A refractometer, and adjust the coolant mixture if necessary.
- Reinstall the expansion tank cap.
- Attach an appropriate scan tool to the vehicle.
- Clear all DTC's using Guided Functions.
- Perform basic settings for the power windows.
- Reset the clock in the instrument cluster.

Work Complete – Proceed to Section D

Section D – Campaign Completion Label and Parts Return/Disposal

Install Campaign Completion Label

- Open the hood.
- Fill out and affix Campaign Completion label, part number CAMP 010 000, next to the vehicle emission control information label



Tip: Ensure Campaign Completion label does not cover any existing label(s)

- Close the hood.

Parts Return/Disposal

Properly destroy or dispose of removed parts in accordance with all state and local requirements, unless otherwise indicated and/or requested through the Warranty Parts Shipping Portal (WPSP) for U.S. and SAGA for Canada.

ALL WORK IS COMPLETE