

[Previous Screen](#)

SB-10055694-5536

Welcome: chrismk2

< Product: NO EQUIPMENT SELECTED
 Model: NO EQUIPMENT SELECTED
 Configuration: NO EQUIPMENT SELECTED

Special Instruction

Procedure to Install the Bottom Side Hood Support Bracket on the CT660{7000}

Media Number -REHS9187-00

Publication Date -30/04/2014

Date Updated -30/04/2014

i05792257

Procedure to Install the Bottom Side Hood Support Bracket on the CT660{7000}

SMCS - 7000

On Highway Truck:

CT660 (S/N: TGA1-UP; TGD1-UP; TEJ1-UP; TRK1-UP; TKL1-UP; TEM1-UP; TEP1-UP; TJS1-UP; TGT1-UP; TSW1-UP; TSY1-UP; TGZ1-UP)

Introduction

The procedure below explains the process to add a support bracket to the bottom side of the hood. This bracket will help prevent hood cracks.

Parts Required

Table 1

Item	QTY	New Part Number	Part Name	Where Used
1	1	453-3613	Support-Hood	112 BBC Hood
2	1	453-3614	Support-Hood	116 BBC Hood
3	2	Obtain Locally	Rivets	
4	1	Obtain Locally	Adhesive	

Work Procedure

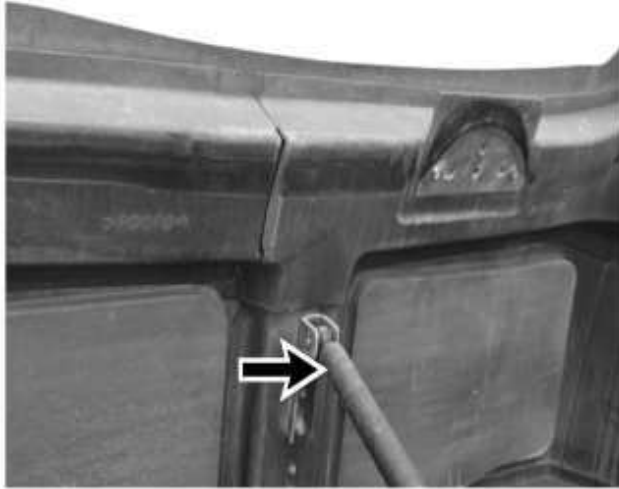

Illustration 1

g03670555

1. Remove the hood damper.

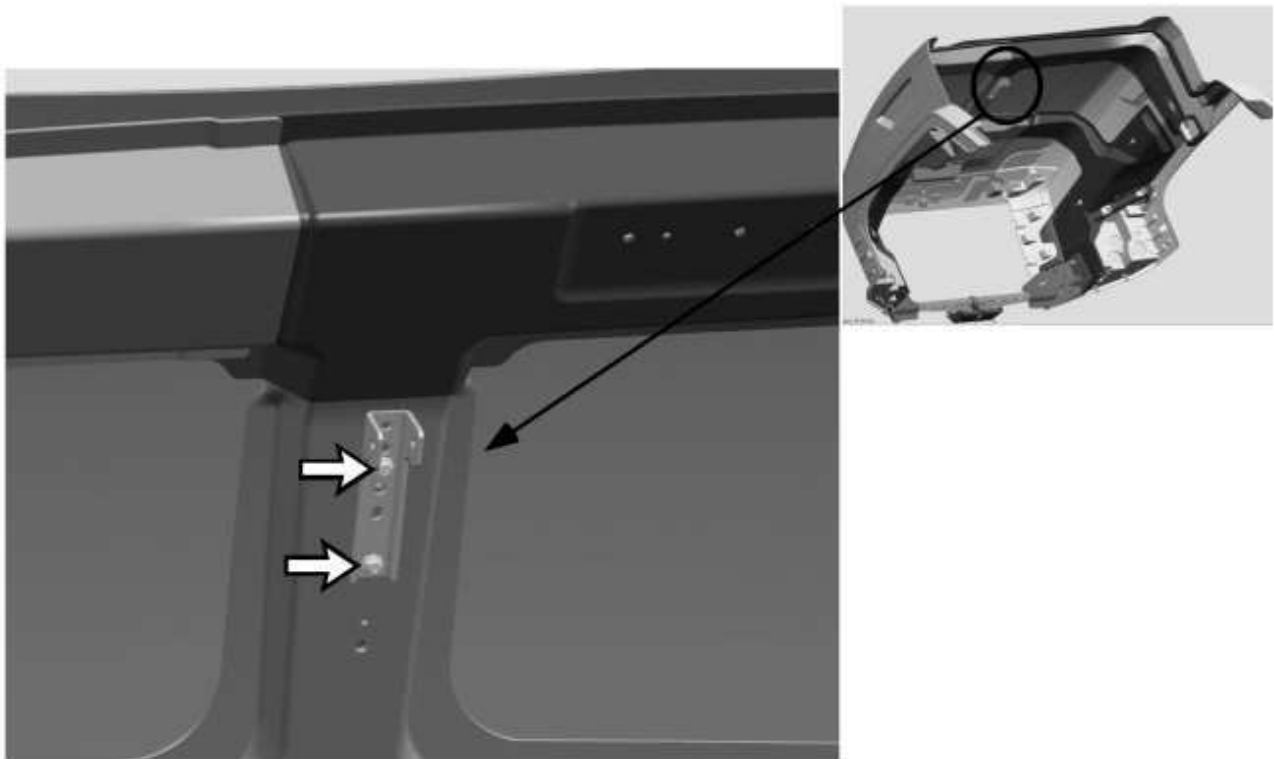

Illustration 2

g03670558

2. Remove the bolts from the hood damper bracket to remove the bracket

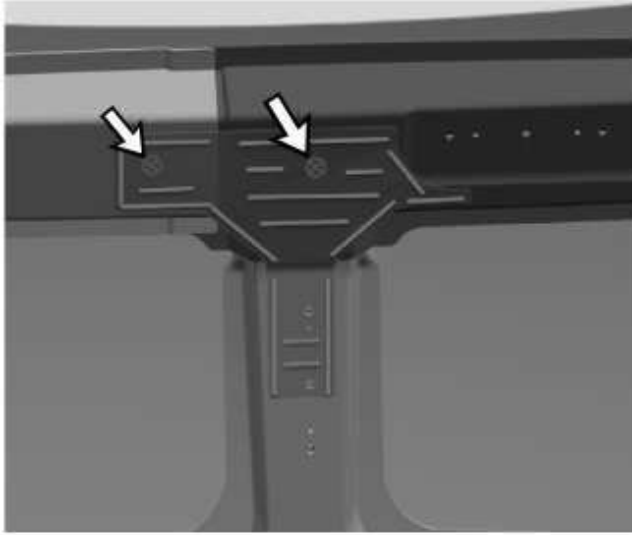

Illustration 3

g03670561

- Put adhesive bead at shown locations for attaching T-bracket to rest of hood assembly and mount T-bracket (working time of adhesive = 4-6 minutes time when adhesive is applied until T-bracket is placed) with help of C-clamps to hold pressure. Put rivets at shown locations. Wait for at least hour and half for adhesive to cure.

Note: Mounting locations for damper bracket should not be covered in adhesive and must be open for attaching bolts.

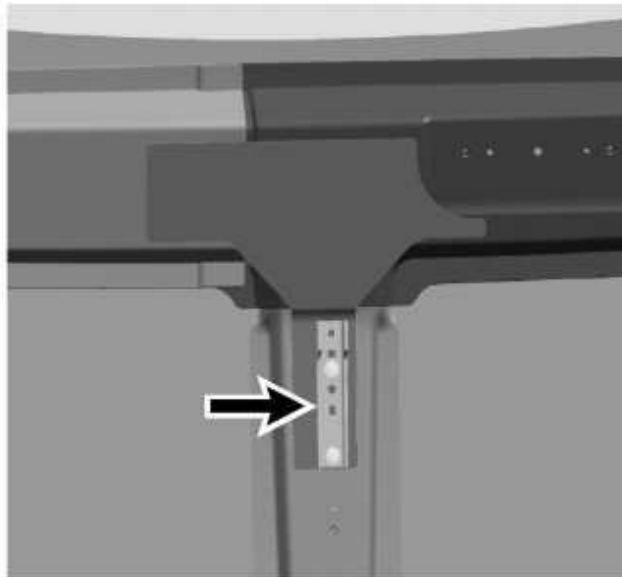

Illustration 4

g03670566

4. Attach the damper mounting bracket and the damper back to hood assembly with bolts

Note: Make sure when you reinstall the hood strut that the barrel end is down (mounted on radiator) rod end is up (on hood).

Copyright 1993 - 2014 Caterpillar Inc.
All Rights Reserved.
Private Network For SIS Licensees.

Wed May 07 2014 09:43:31 GMT-0500 (Central Daylight Time)
chrismk2