

**SB-10055694-1383****Service Information System**[Previous Screen](#)

Welcome: davidaa

◀ Product: NO EQUIPMENT SELECTED  
 Model: NO EQUIPMENT SELECTED  
 Configuration: NO EQUIPMENT SELECTED

**Special Instruction****Procedure to Install the Bottom Side Hood Support Bracket on the CT660{7000}**

Media Number -REHS9187-02

Publication Date -2014/06/18

Date Updated -2014/06/18

i05833475

**Procedure to Install the Bottom Side Hood Support Bracket on the CT660{7000}**

SMCS - 7000

**On Highway Truck:**

CT660 (S/N: TGA1-UP; TGD1-UP; TEJ1-UP; TRK1-UP; TKL1-UP; TEM1-UP; TEP1-UP; TJS1-UP; TGT1-UP; TSW1-UP; TSY1-UP; TGZ1-UP)

**Introduction**

The procedure below explains the process to add a support bracket to the bottom side of the hood. This bracket will help prevent hood cracks.

**Parts Required**

Table 1

Item	QTY	New Part Number	Part Name	Where Used
1	1	453-3613	Support-Hood	122 inch BBC Hood
2	1	453-3614	Support-Hood	116 inch BBC Hood
3	2	Obtain Locally	Rivets	
4	1	Obtain Locally	Adhesive	

**Note:** Please use one of the following adhesives to attach the hood bracket.

- **"ITW Plexus"** - AO420, MA420, MA1021 (used in production)
- **"Pilogrip"** - 6600, 7525 A/B
- **"Hysol"** - EA9460
- **"Arathane"** - 8680, 5541
- **"Fusor"** - 7525 A/B

## Work Procedure

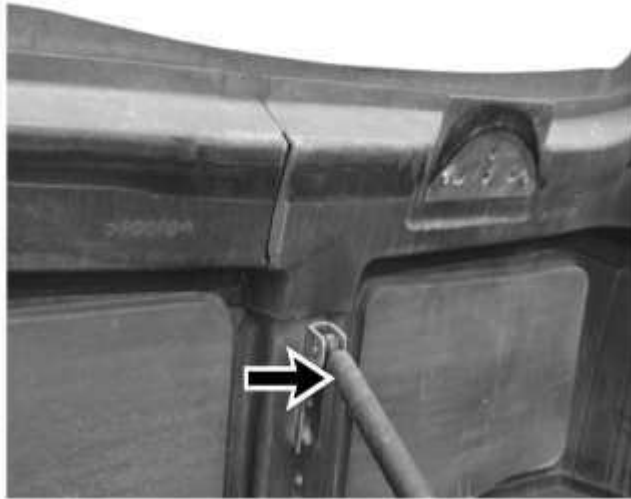

Illustration 1

g03670555

1. Remove the hood damper.
-

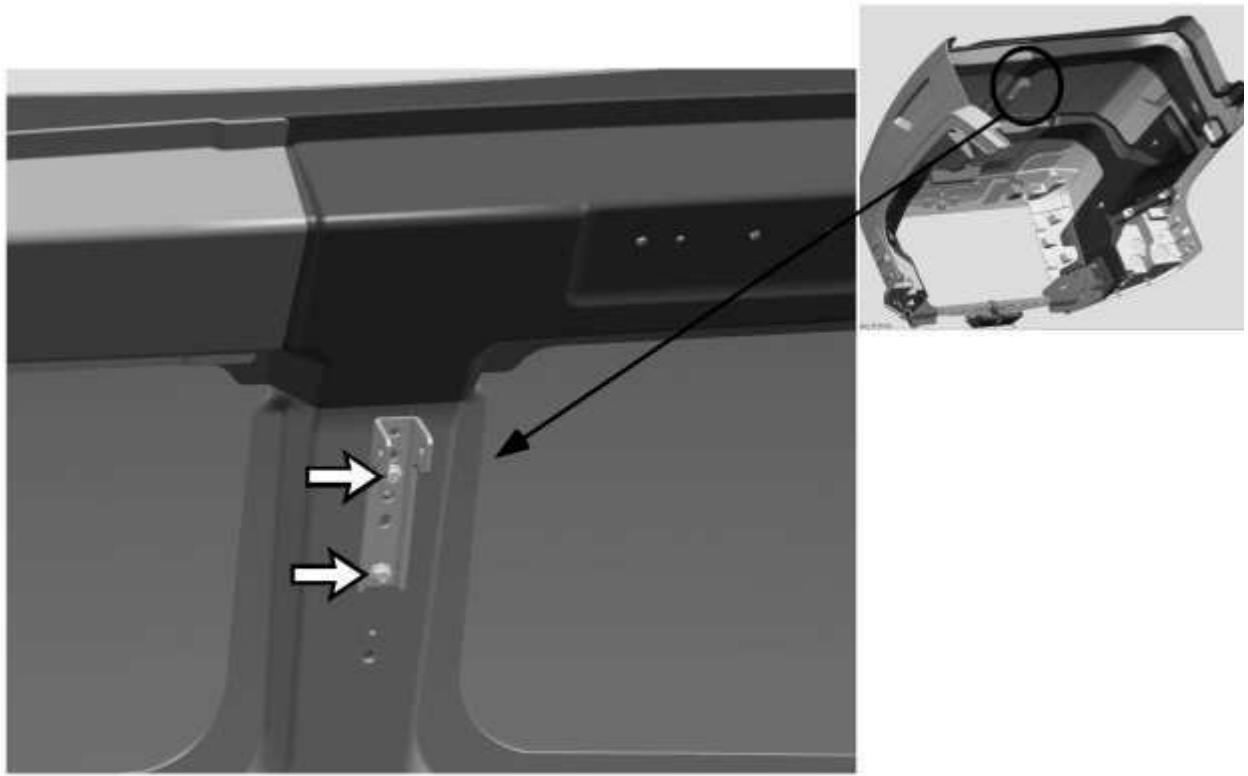

Illustration 2

2. Remove the bolts from the hood damper bracket to remove the bracket

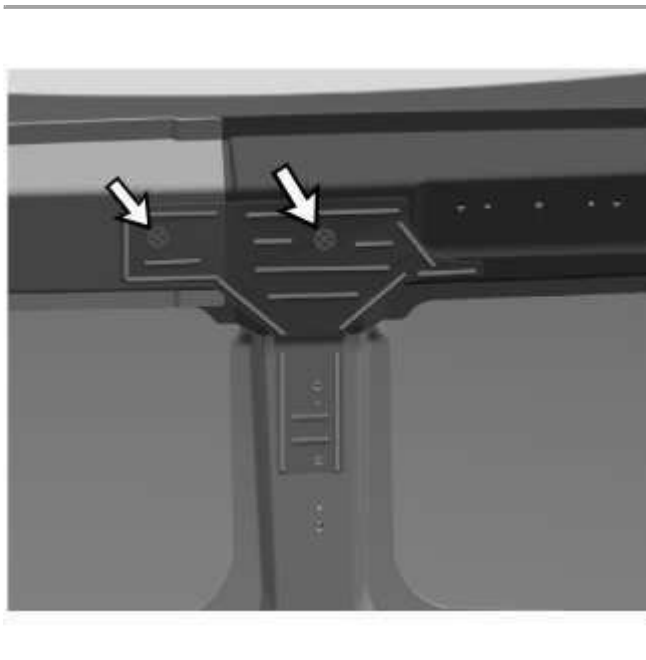

Illustration 3

g03670561

- Put adhesive bead at shown locations for attaching T-bracket to rest of hood assembly and mount T-bracket (working time of adhesive = 4-6 minutes time when adhesive is applied until T-bracket is placed) with help of C-clamps to hold pressure. Put rivets at shown locations. Wait for at least hour and half for adhesive to cure.

**Note:** Mounting locations for damper bracket should not be covered in adhesive and must be open for attaching bolts.

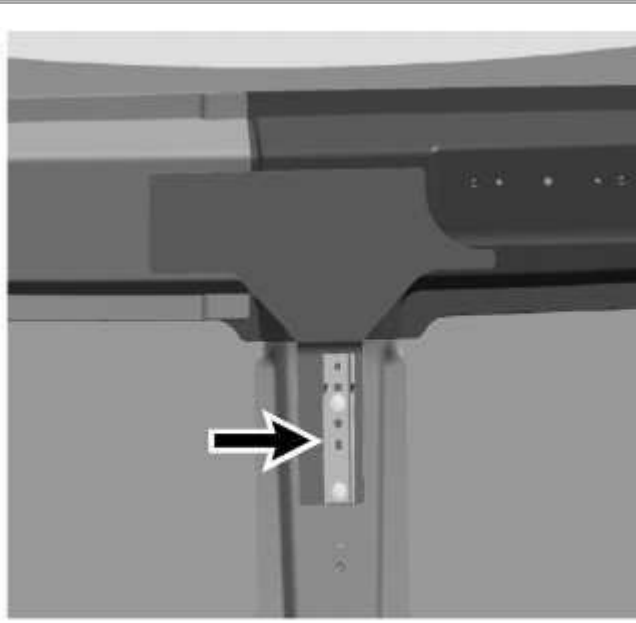

Illustration 4

g03670566

- Attach the damper mounting bracket and the damper back to hood assembly with bolts

**Note:** Make sure when you reinstall the hood strut that the barrel end is down (mounted on radiator) rod end is up (on hood).