

This bulletin replaces bulletin "FSB 432-013, AMT High Range Cone Replacement" released 04.2014.

Date 5.2014 Group **432** No. **013** Release **02** Page 1(32)

AMT High Range Cone  
 Replacement  
 VN, VHD, VAH, VT

**FSB 432-013, AMT High Range Cone Replacement**

(May 2014)

This document provides the recommended procedure for replacing the high range section of the Automated Manual Transmission (AMT) including the high range cone.

**Required Parts:**

- 1 – Part Number 85013966, I-Shift Range Synchronizer Service Kit

Service personnel: Please circulate, read and initial

Service Manager	Warranty Administrator	Workshop Foreman	Service Technicians						

## Procedure

You must read and understand the precautions and guidelines in Service Information, group 40, "General Safety Practices, Transmission" before performing this procedure. If you are not properly trained and certified in this procedure, ask your supervisor for training before you perform it.



### **DANGER**

Do not attempt to repair or service this vehicle without having sufficient training, the correct service literature and the proper tools. Failure to follow this could make the vehicle unsafe and lead to serious personal injury or death.



### **DANGER**

Before beginning any work on any part of the air system, be certain that the air pressure has been released. Failure to do so may cause a component to violently separate, which can result in serious personal injury.

**Note:** Special tools: 85108826, 9996876

- 1 Using Premium Tech Tool, perform the "Gear Activation, Control Housing (for Removal/Installation)". Follow the instructions as outlined within Premium Tech Tool.  
**Note:** If Tech Tool is unable to activate the necessary gears for control housing removal, follow the manual activation steps outlined in this procedure after transmission removal.
- 2 Secure the vehicle for service by parking it on a flat level surface, applying the parking brake, chocking the rear wheel, and placing the transmission in neutral.
- 3 Disconnect all cables from the negative (ground) battery terminals to prevent personal injury from electrical shock and prevent damage to electrical components.
- 4 Drain the air system.
- 5 Raise the vehicle and support with jack stands.

- 6 Disconnect the transmission oil cooler hoses from the filter housing. Use tool 85108826.

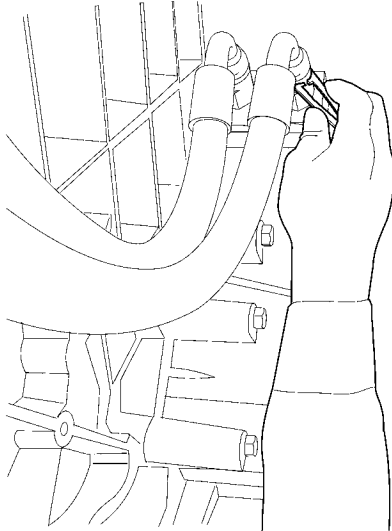

W4002890

- 7 Remove the drive shaft.

**Note:** Remove the universal joint caps and the bolts holding the intermediate bearing to the support bracket (if equipped).

**Note:** Mark the position of the bolts on the bracket so that the intermediate bearing is installed in exactly the same position as before. Position the shaft aside.

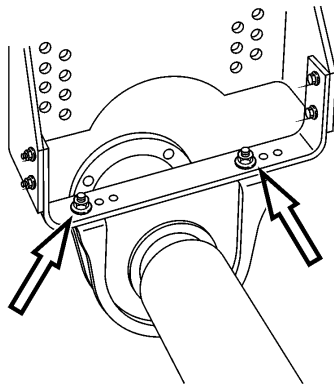

T4018155

- 8 Disconnect the air supply hose at the rear of the transmission.

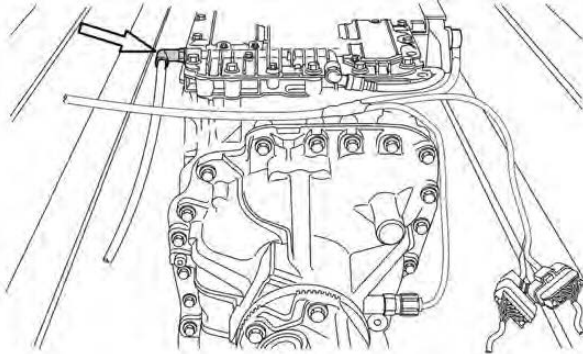

W4002940

- 9 Remove the tie straps securing the wiring harness to the transmission.  
10 Disconnect the electrical harness at the control housing, speed sensor, and the two chassis connectors.

**Note:** Position the harness out of the way.

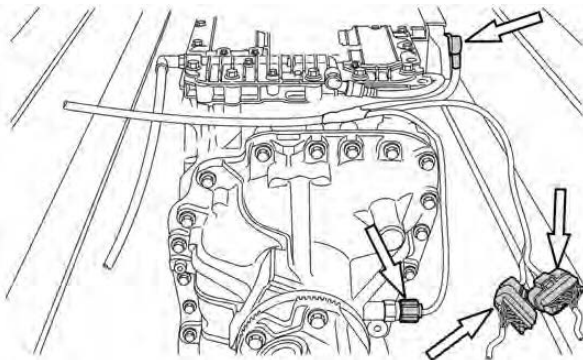

W4002941

- 11 Remove the cab engine cover.  
12 Remove the transmission-to-engine mounting bolts along the bottom and sides of the clutch housing.

**Note:** Do not remove the top four transmission-to-engine mounting bolts at this time.

- 13 Position the transmission jack and secure the transmission to the jack
- 14 Remove the top four transmission-to-engine mounting bolts.
- 15 Carefully pull the transmission back until the input shaft clears the pressure plate. Lower the transmission and pull it out from under the vehicle.

**Note:** While lowering the transmission, periodically check around it to assure nothing is caught or hung up on it such as wiring or air hoses.

- 16 Disconnect the clutch valve wiring connector at the control housing.

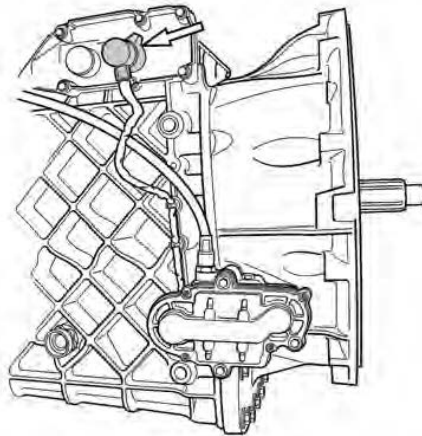

W4002881

- 17 Disconnect the clutch control valve air supply tube at the upper control housing fitting.

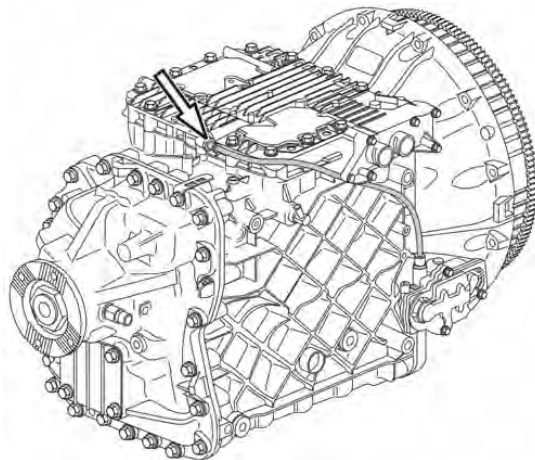

W4002947

18 Remove the control housing mounting bolts.

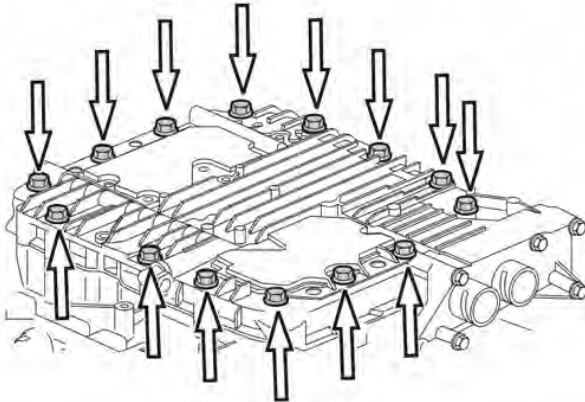

W4002951

19 Remove the six TECU mounting bolts.

**Note:** It is **only** necessary to perform this step if; replacing the control housing **without** a new TECU or, if manually performing the “Gear Activation, Control Housing (for Removal/ Installation)”. If Premium Tech Tool activated the necessary gears, proceed to step 23.

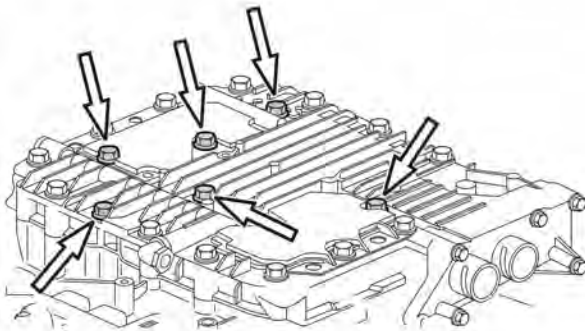

W4002952

20 Manually perform the “Gear Activation, Control Housing (for Removal/Replacement)” as outlined in the next three steps.

**Note:** The next three steps are performed **only** if Tech Tool could not activate the necessary gears for control housing removal.

21



### CAUTION

Electrical components, including the wiring harness inside the transmission control housing, are delicate. Handle with extreme care. Failure to do so may result in damage to components.

Gently lift the top edge of the upper cover and angle it down carefully against the clutch housing. Carefully disconnect the electrical connection and remove the top cover.

**Note:** Do not apply tension or weight to the wiring harness or connector.

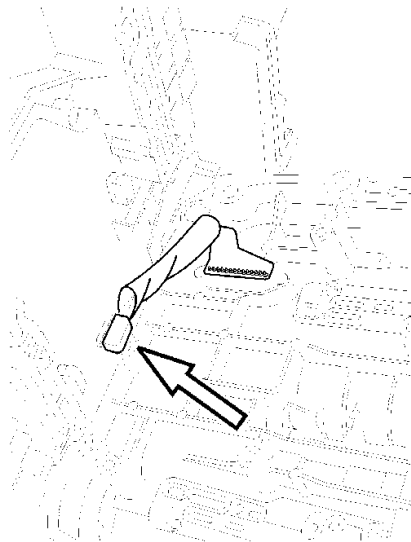

W4002953

22 Using compressed air, apply air pressure to the appropriate bore holes to place the transmission gears in the proper position for control housing removal.

**Note:** It is necessary to rotate the input shaft while engaging the splitter section to mesh the gears.

**Note:** It is necessary to rotate the output shaft while engaging the range section to mesh the gears.

**Note:** It is necessary to rotate the output or input shaft while engaging reverse to mesh the gears.

**Note:** For over drive transmissions, the transmission must be positioned as follows:

- \* Low Split
- \* High Range
- \* 2nd/3rd — Neutral Position
- \* 1st/Reverse — Reverse Position

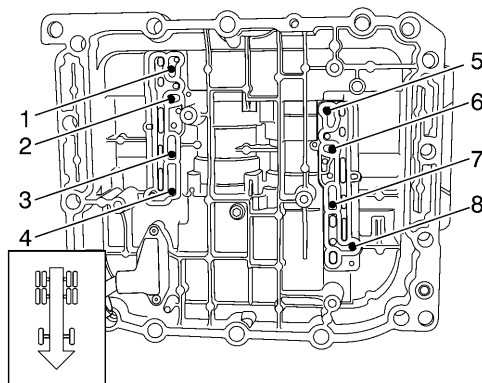

W4002895

### Over Drive Transmission

- 1 – High Range
- 2 – 3rd Gear
- 3 – Low Range
- 4 – 2nd Gear
- 5 – 1st Gear
- 6 – High Split
- 7 – Reverse Gear
- 8 – Low Split



**Note: For direct drive transmissions, the transmission must be positioned as follows:**

- \* High Split
- \* High Range
- \* 2nd/3rd — Neutral Position
- \* 1st/Reverse — Reverse Position

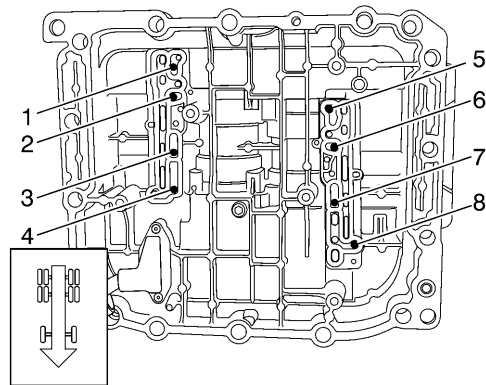

W4002895

**Direct Drive Transmission**

- 1 – High Range
- 2 – 3rd Gear
- 3 – Low Range
- 4 – 2nd Gear
- 5 – 1st Gear
- 6 – Low Split
- 7 – Reverse Gear
- 8 – High Split

**Note:** If 2nd or 3rd gear is engaged, it will be necessary to position that gear set to neutral before attempting to engage reverse.

**Note:** To engage neutral for the 2nd/3rd gear set, it will be necessary to gently apply air to the bore holes. If too much air is applied, it will engage one of the two gears. To aid positioning, **do not** rotate the shaft when attempting to position this gear set.

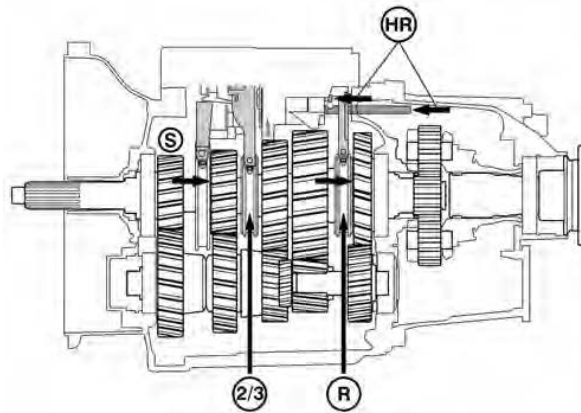

T4021451

23



**CAUTION**

Gentle consistent pressure should be used to lift the control housing from the transmission. Applying excessive force is not necessary or needed, and may result in damage to components.



**CAUTION**

Always install the alignment pins before removing the control housing to prevent damage to the transmission main shaft speed tone ring and the shift control.

**Note:** Use tool **9996876**.

Install the alignment pins through the control housing into the transmission. Using a pry bar, gently separate the control housing from the locating pins on the transmission, then remove the control housing.

**Note:** If the control housing does not separate from the transmission while applying gentle pressure upward, it may be necessary to refer back to Step 23 or Step 24 before attempting control housing removal again.

**Note:** Exercise care during removal to keep from damaging the tooth wheel in the transmission.

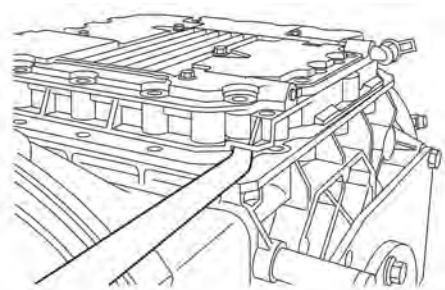

W4002955

24



**WARNING**

Hot oil can cause burns. Use protective gloves.

Remove the transmission oil drain plug and drain the transmission oil into a suitable container. Install the transmission oil drain plug and tighten to specification, refer to Function Group 431, Transmission, Mechanical.

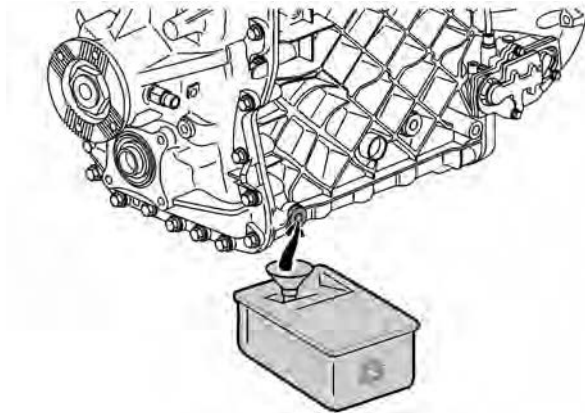

T4022639

25 Remove the oil filter oil drain plug and drain the transmission oil into a suitable container. Install the oil filter drain plug and tighten to specification, refer to Function Group 431, Transmission, Mechanical.

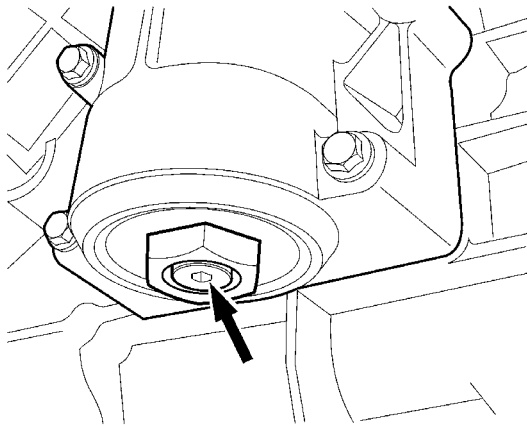

W4002889

- 26 Turn the transmission so that the output shaft flange faces upwards.
- 27 Remove the plug, spring, and blocking body for the range function.

**Note:** If necessary, use a magnet to pull out the blocking body.

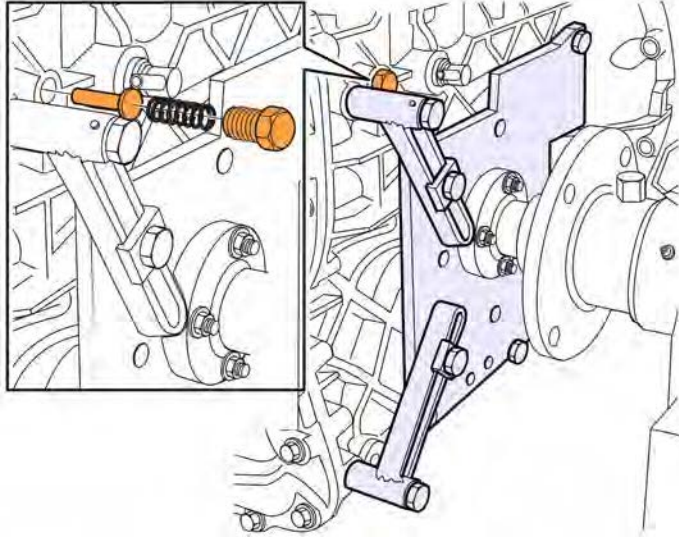

C4052785

28 Split the main housing and range housing using the press tool.

**Note:** 9998051

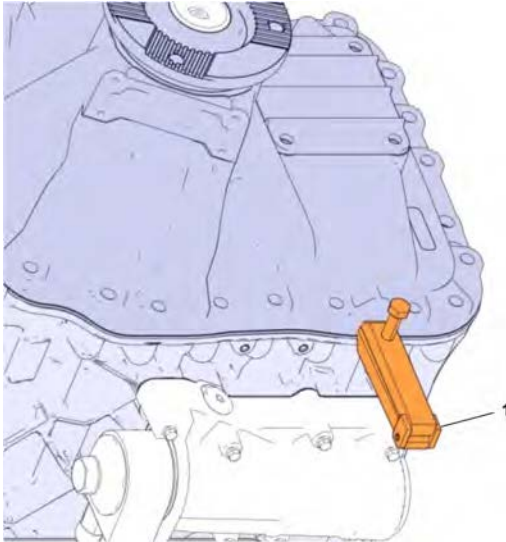

W4088216

29 Lift the range housing away carefully.

**Note:** Ensure that the range cylinder piston rod does not jam in the transmission housing. the shaft may then be damaged.

30 Remove the oil distributor pipe using the special tool socket.

**Note:** 9990027

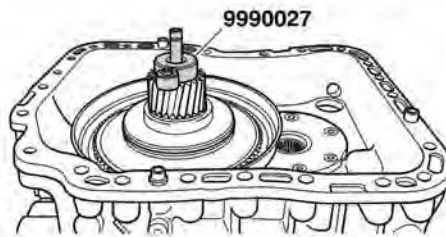

T4021428

31 Remove the snap ring securing the high range synchronizer cone.

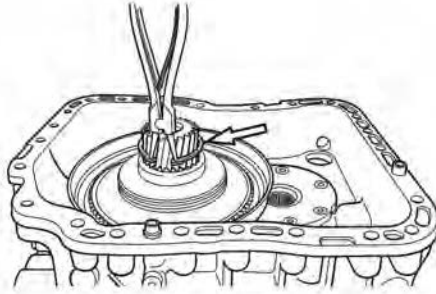

T4021426

32 Remove both halves of the washer.

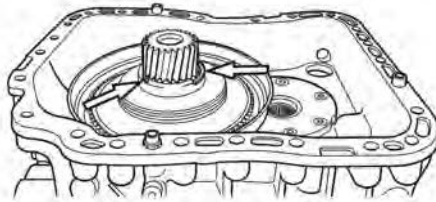

T4021427

33 Install both the puller halves onto the high range synchronizer cone.

**Note:** 88800015

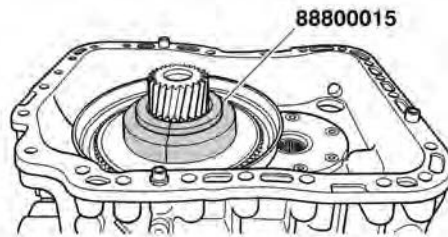

T4021425

34 Install one half of the puller 9998542 onto the puller rings, together with the hydraulic cylinder, spindle, and drift.

**Note:** Ensure that the split in the puller rings is at 90 ° to split the puller.

**Note:** 88800015, 9992619, 9992671, 9996889, 9998542

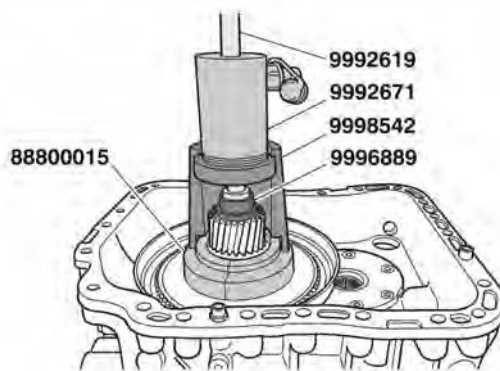

T4021429

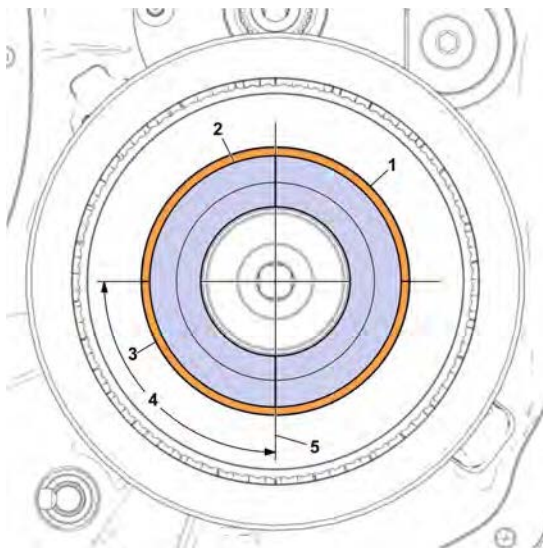

W4089791

- 1 – 88800015
- 2 – Puller Ring
- 3 – 9998542
- 4 – 90 ° Position for Tool
- 5 – Tool Set on Puller Ring



35 Install the other half of the puller 9998542. Install the hydraulic pump. Press off the high range synchronizer cone.

**Note:** 9996222

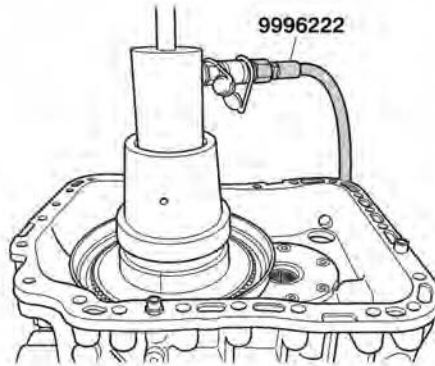

T4021430

**Note:** After removing the cone check the part number of the spacer. If the part number is 20533124 then replace the spacer with a new spacer included in the I-Shift Range Synchronizer Service Kit (part number 85013966).

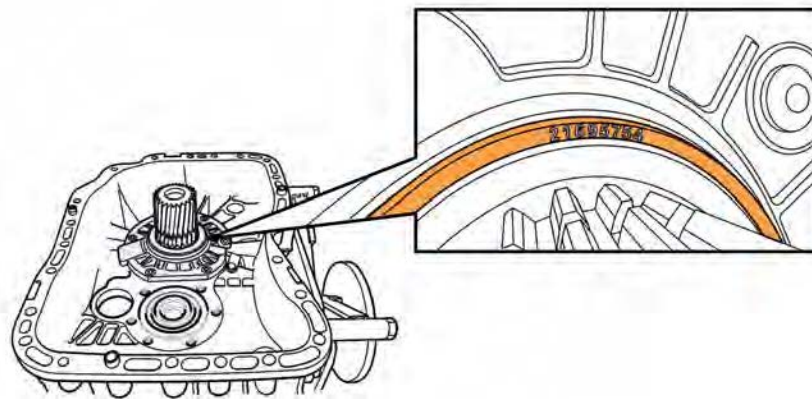

W4089323

**Note:** The next three steps are required **ONLY** if the spacer is replaced.

36 Remove the rear cover for the main shaft and where applicable oil pipe for overdrive gear.

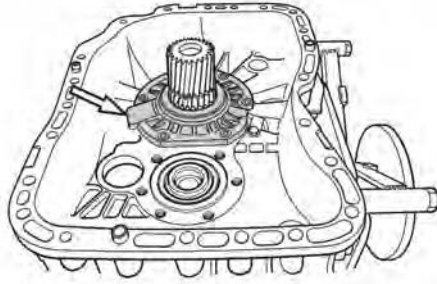

T4021434

37 Remove the adjustment shim for the main shaft.

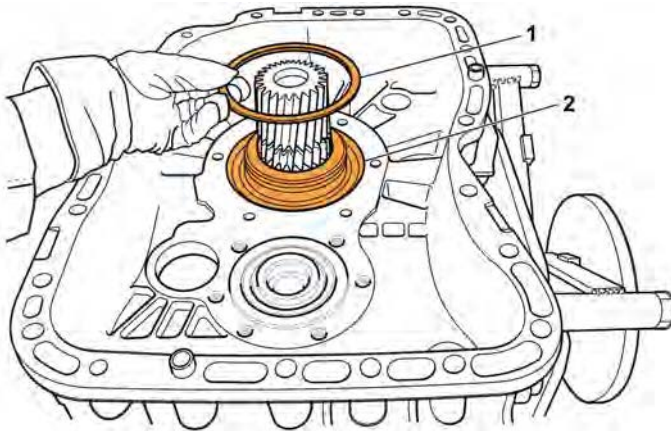

W4088866

- 1 – Shim
- 2 – Spacer

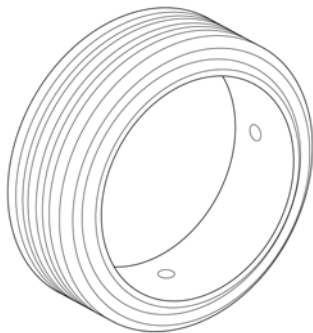

W4089450

Spacer

- 38 Remove the spacer with a suitable tool and replace with the spacer included in the kit.
- 39 Reinstall the shim.
- 40 Reinstall the rear cover. Torque fasteners to  $40 \pm 5$  Nm ( $30 \pm 4$  ft-lb).
- 41 Press on the new high range cone.

**Note:** 88800015, 9992671, 9996222, 9996315, 9998542

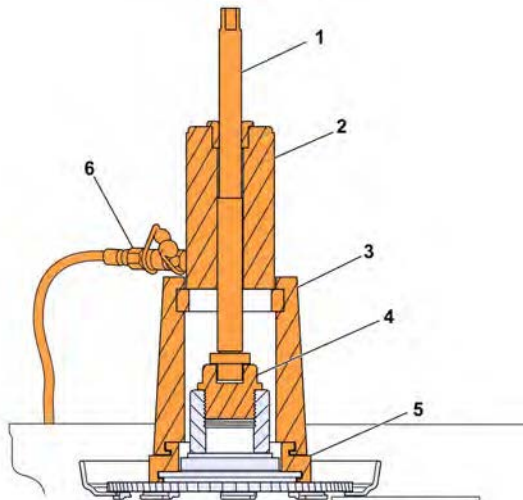

W4089452

- 1 – 9996315
- 2 – 9992671
- 3 – 9998542
- 4 – 9996917
- 5 – 88800015
- 6 – 9996222

- 42 Install both the washer halves.

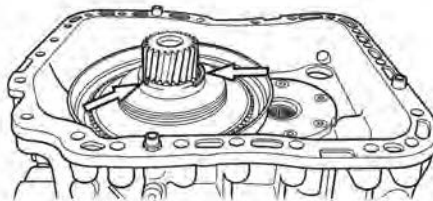

T4021427

43 Install the high range snap ring.

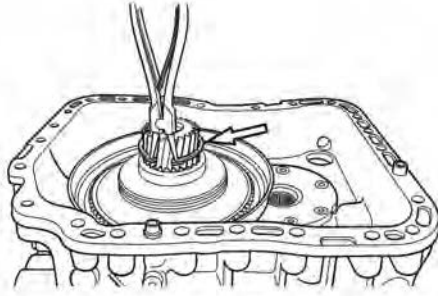

T4021426

**Note:** Insure a tight fit between the snap ring and the groove. Several different thickness snap rings have been included in the kit. Use the largest snap ring that will completely seat in the groove with the least amount of axial movement.

44 Oil and install new O-rings onto the oil distribution piping. Install the oil distribution piping. Tighten the oil distribution piping to  $250 \pm 35$  Nm ( $184 \pm 26$  ft-lb).

**Note:** 9990027

45 Apply an approved high-temperature liquid gasket to the mating surface of the main transmission housing.

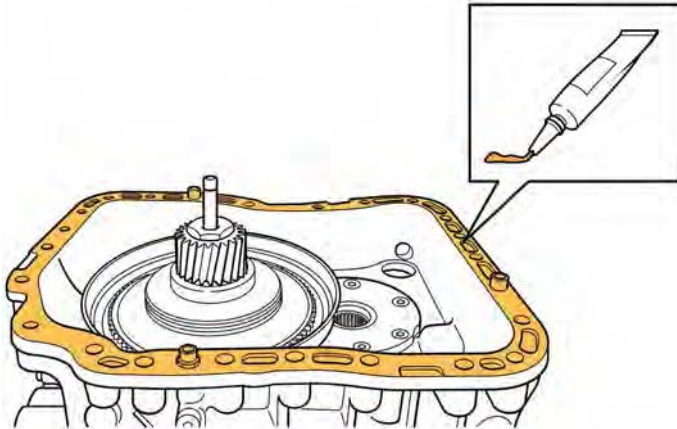

W4089451

46 Position the range housing over the main housing. Lower and line up the piston rod and planet wheel. Install the fasteners and tighten to  $110 \pm 10$  Nm ( $81 \pm 7.4$  ft-lb).

**Note:** Insert the guide pins 9996876 into the transmission housing to facilitate the assembly.

**Note:** 9996876

47 Check that the control housing sealing surface is clean. Install a new control housing gasket.

**Note:** When installing a new gasket on a C design level transmission, some gasket material will protrude from the control housing. Trim excess gasket material.

**Note:** Clean any dirt and corrosion from the alignment dowels in the housing and from the dowel holes in the control housing assembly to aid in reinstallation.

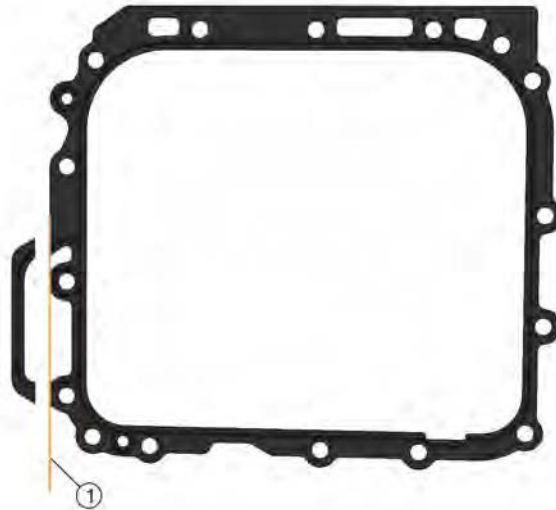

W4055781

48 Ensure that the split engaging ring is in its rear most position. Ensure that the 2nd/3rd engaging ring is in neutral or middle position and that the reverse gear engaging ring is in its rear most position (Figure 1). Also ensure that the range gear is in high range (Figure 2).

**Note:** Ensure that the new control housing forks correspond to the position of the engaging rings. If they do not correspond, gently position them by hand.

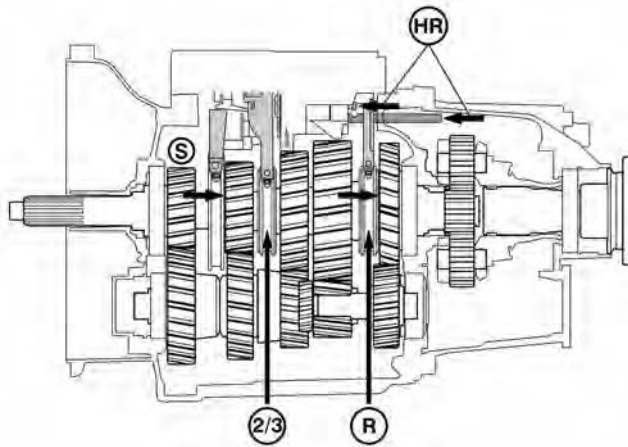

T4021451

Figure 1

HR – High Range

S – Split

2/3 – 2nd/3rd gear in neutral

R – Reverse gear

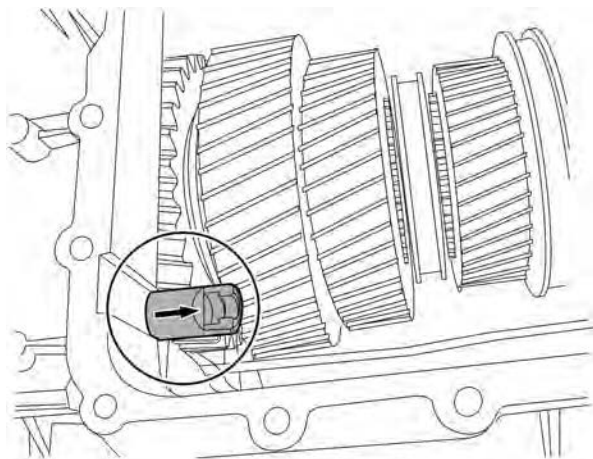

W4002948

Figure 2

49 Ensure that the range servo piston is positioned out 25.4 mm (1 in.) to properly mate with the main housing.

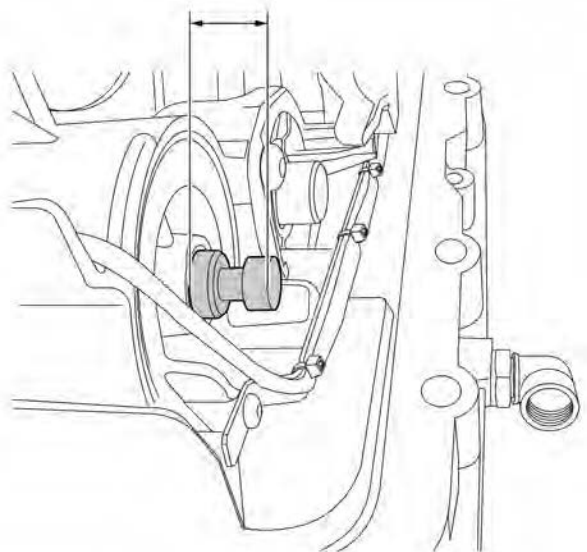

W4002950

50



**CAUTION**

Always install the alignment pins before installing the control housing to prevent damage to the transmission main shaft speed tone ring and the speed sensor.

Install the alignment pins in the transmission.

**Note:** 9996876

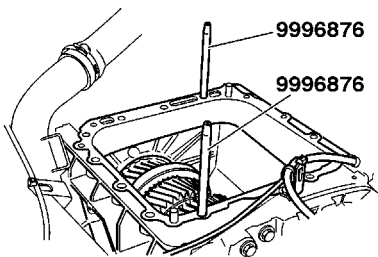

T4018982



51



### CAUTION

To avoid component damage gently install the control housing with little more than gentle taps to seat in place. If the control housing does not install easily, remove and check the alignment of components in the gearbox and the control housing assembly. Forcing the control housing can cause un-repairable damage and requires a component replacement.

Carefully lower the control housing to avoid damaging the tooth wheel in the transmission. Ensure that the split fork ends up in the correct position in engaging ring. Remove the alignment pins.

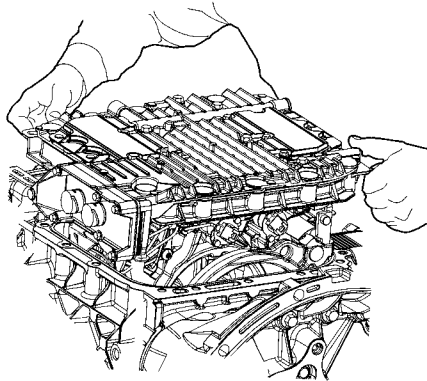

W4002949

52 Installed new solenoid valve seals, an O-ring for the counter-shaft brake and a new upper cover gasket.

**Note:** Only perform this and the following steps if the control housing was replace without a new upper cover. If replacing the control housing as a complete assembly proceed to 55.

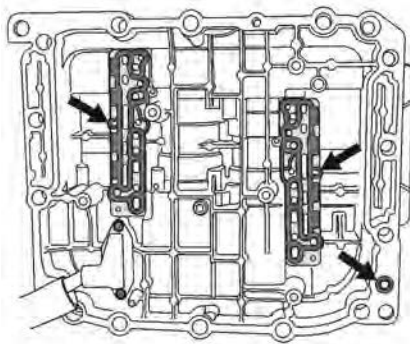

T4020778

53

 **CAUTION**

Electrical components, including the wiring harness inside the transmission control housing, are delicate. Handle with extreme care. Failure to do so may result in damage to components.

Place the new upper cover in position and carefully connect the wiring harness. Lower the upper cover into position.

**Note:** Do not apply tension or weight to the wiring harness or connector.

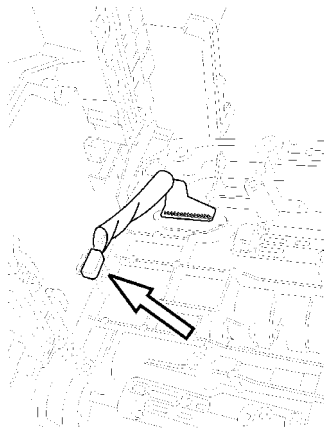

W4002953

54 Install and torque the six upper cover mounting bolts. Torque fasteners to  $24 \pm 4$  Nm ( $18 \pm 3$  ft-lb).

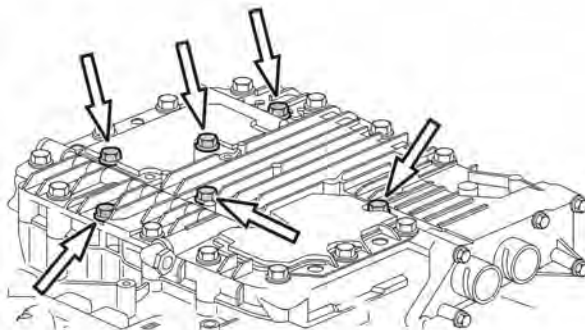

W4002952

55 Install the control housing. Torque the fasteners to  $110 \pm 10$  Nm ( $81 \pm 7$  ft-lb).

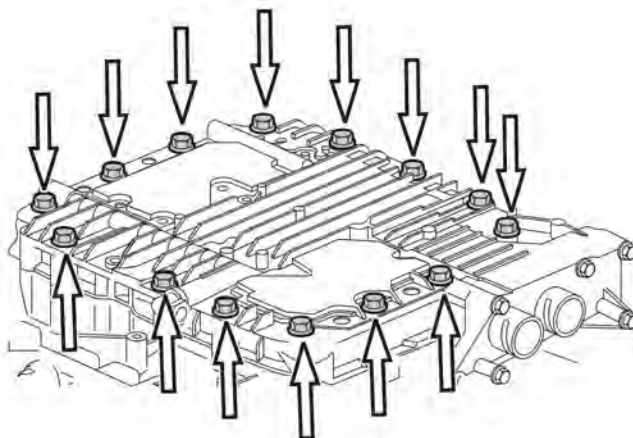

W4002951

56 Connect the clutch control valve air supply tube to the upper control housing fitting.

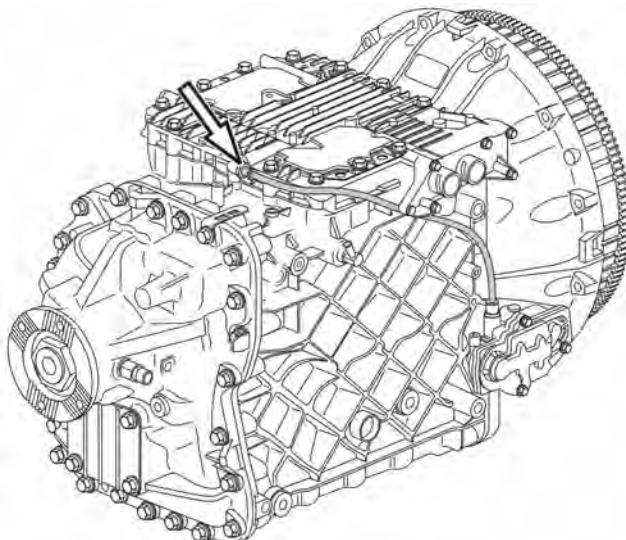

W4002947

57 Install the blocking body, spring and plug for the range function.

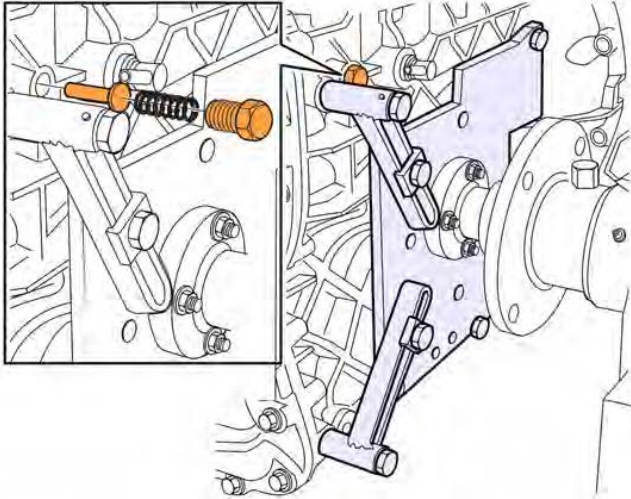

C4052785

58 Connect the clutch valve wiring connector to the control housing.

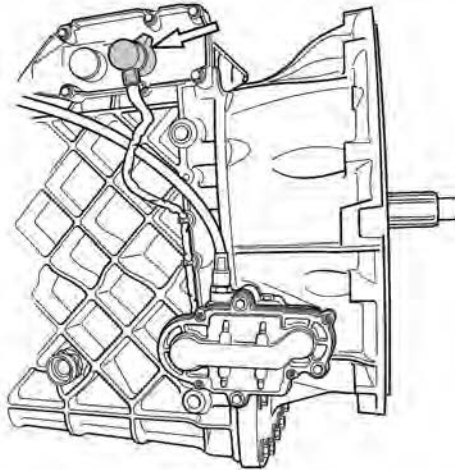

W4002881

59 After the control housing has been installed, use Premium Tech Tool (PTT) to perform operation 4000-07-04-01 "Transmission Calibration (Transmission Removed)".

**Note:** If calibration fails, check that the shift fork position sensor values are within the specification ranges. Shift fork values out of range may indicate incorrect assembly of shift forks to engaging rings preventing correct transmission shifting. Remove control housing and inspect shift fork and engaging ring positions. Repeat the control housing installation.

60 To aid transmission installation, remove the service plug on the clutch control valve assembly. Clean around the plug prior to removal to prevent debris from entering the valve. Place a clean shop rag over the open port to prevent debris from entering the valve during installation. Once the installation is complete replace the plug and torque to  $7 \pm 2$  Nm ( $5 \pm 1$  ft-lb).

**Note:** Failure to perform this step will hamper installation. The transmission will be installed under clutch cylinder spring pressure and will fail to freely slide forward into place against the flywheel housing mating surface.

61 Carefully install the transmission and align to the engine. Loosely install two upper and two lower transmission-to-engine mounting bolts to hold the transmission in place.

**Note:** The use of an assistant may be necessary to aid during installation.

**Note:** Rotate the input shaft to align the clutch splines.

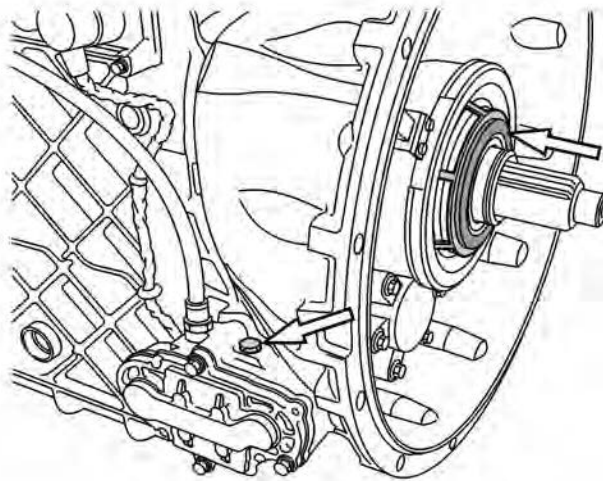

T4021203

62 Install the remaining transmission-to-engine mounting bolts. Torque to  $92 \pm 8$  Nm ( $68 \pm 6$  ft-lb). Remove the transmission jack.

**Note:** To aid access, install and tighten the mounting bolts on the top of the clutch housing first. Remove the transmission jack and install the remaining mounting bolts.

63 Position the battery cables and install their mounting bolts.

64 Install the cab engine cover.

65 Position the electrical harness and reconnect the control housing, speed sensor and two chassis connectors.

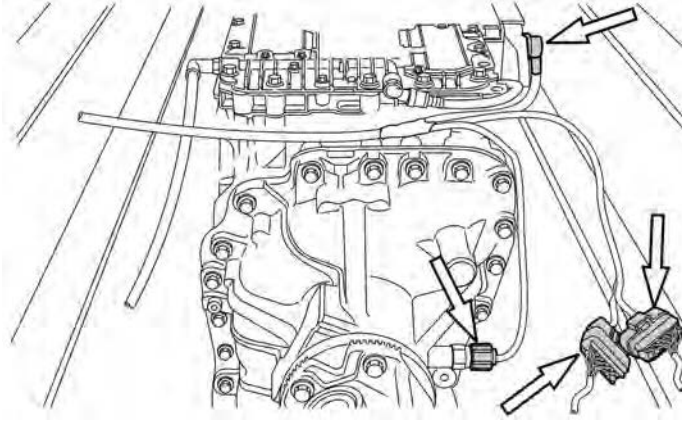

W4002941

66 Install new tie straps to secure the wiring harness to the transmission.  
67 Connect the air supply hose at the rear of the transmission.

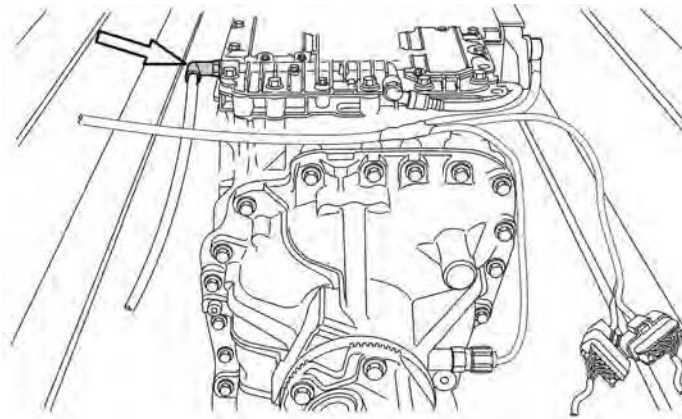

W4002940

68 Connect the transmission oil cooler hoses to the filter housing.

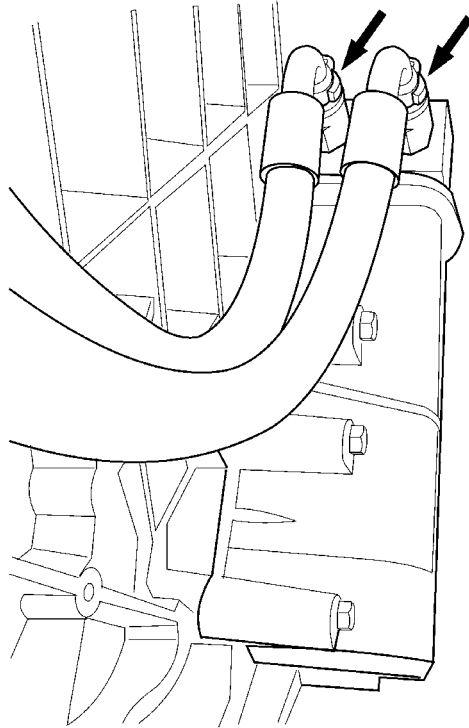

W4002894

69 Install the drive shaft, the universal joint caps and the bolts holding the intermediate bearing to the support bracket if equipped).

**Note:** It is important to center the rubber insulator in the U-bracket correctly.

\* Intermediate Bearing:  $105 \pm 20$  Nm ( $78 \pm 15$  ft-lb)

\* Universal Joint Caps:  $170 \pm 15$  Nm ( $125 \pm 10$  ft-lb)

70 Remove the supporting jack stands and lower the vehicle.

71 Pressurize the air system and check for leaks.

72 Connect all previously removed cables to the negative (ground) battery terminals. Tighten fasteners to  $20 \pm 2$  Nm ( $15 \pm 1.5$  ft-lb).

73 Check and fill the transmission with approved transmission oil.

74 Use Premium Tech Tool to perform a "clutch engagement position calibration".

**Note:** If a new transmission control module (TCM) was installed with the control housing, configure the TCM with its software prior to performing the "clutch engagement position calibration".

**Reimbursement**

<b>This repair may be eligible for reimbursement if a product failure was experienced within time and mileage limits of the applicable Warranty coverage. Reimbursement is obtained via the normal claim handling process.</b>	Reimbursement UCHP	Reimbursement eWarranty
<b>Claim Type (used only when uploading from the Dealer Bus. Sys.)</b>	W	W
<b>Labor Code</b>		
Primary Labor Code	4329-03-09-01 8.4 hrs.	43251-2-00 — 8.4 hrs.
<b>Causal Part</b>	21480996	21480996

Volvo Trucks North America reserves the right to make any changes in design or to make additions to or upon its products without incurring any obligations to install the same on vehicles previously built.