



Technical Service Bulletin

SB-10055522-9353

SUBJECT:			No: TSB-14-42B-002REV
FRONT END CROSSMEMBER WELD LOCATIONS – SERVICE MANUAL REVISION (REVISED)			DATE: April, 2014
			MODEL: 2014 Mirage
CIRCULATE TO:	<input type="checkbox"/> GENERAL MANAGER	<input checked="" type="checkbox"/> PARTS MANAGER	<input checked="" type="checkbox"/> TECHNICIAN
<input checked="" type="checkbox"/> SERVICE ADVISOR	<input checked="" type="checkbox"/> SERVICE MANAGER	<input type="checkbox"/> WARRANTY PROCESSOR	<input type="checkbox"/> SALES MANAGER

This bulletin supercedes TSB-14-42B-002, issued February, 2014 to correct the illustration on page 3 of this TSB. Revisions are indicated in red italics.

PURPOSE

This TSB updates the Body Repair Manual with locations of manufacturer's weld points for the front end crossmember.

AFFECTED VEHICLES

2014 Mirage

AFFECTED SERVICE MANUAL

2014 Mirage Body Repair Manual Section 3: Welded Panel Replacement > Front End Crossmember

Replace the following page in the 2014 Mirage Body Repair Manual Section 3 Welded Panel Replacement
 > Front end Crossmember with the new information from page 3.

<Incorrect>

WELDED PANEL REPLACEMENT
 FRONT END CROSSMEMBER

3-33

FRONT END CROSSMEMBER

M4030003100390

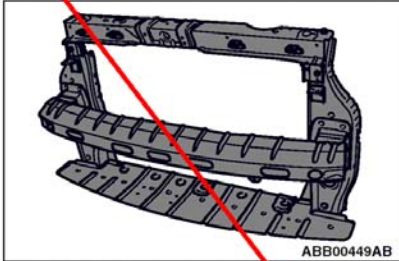

Symbol	Operation description
● ● ● ●	Spot welding
■ ■ ▲ ▲	MIG plug welding (■ : indicates two panels to be welded ▲ : indicates three panels to be welded)
++++	MIG spot welding
	MIG arc welding (continuous)
○○○○○	Braze welding
	Anti-corrosion agent application locations (Use access holes to apply liberally to butt-welded joints.)

REPAIR WELDS

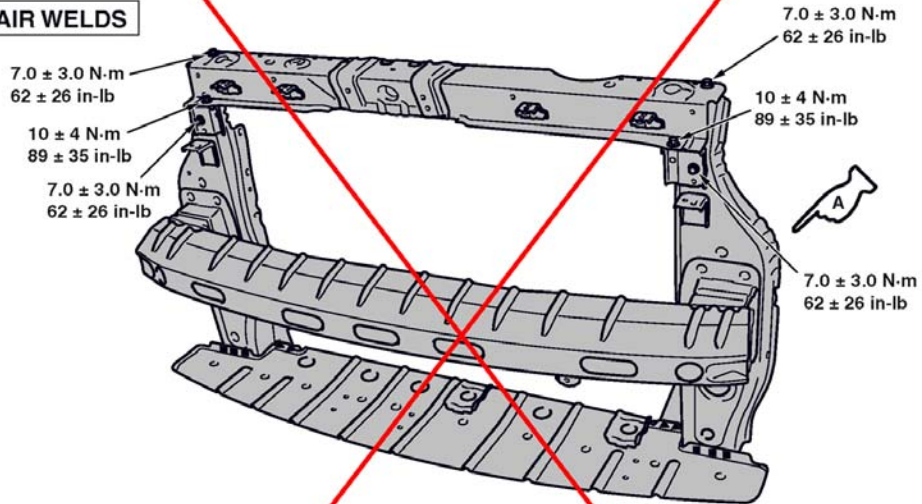

Insert the attached
 sheet 3(2/2)

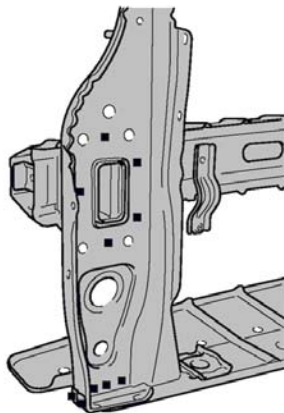

A

ABC00529AB

<Correct>

WELDED PANEL REPLACEMENT
 FRONT END CROSSMEMBER

3-33

FRONT END CROSSMEMBER

M4030003100390

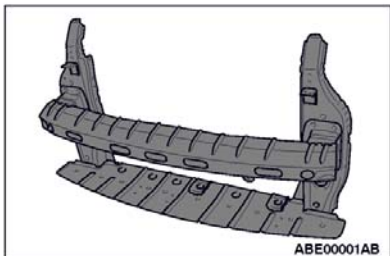

Symbol	Operation description
● ● ● ●	Spot welding
■ ■ ▲ ▲	MIG plug welding (■: indicates two panels to be welded ▲: indicates three panels to be welded)
++++	MIG spot welding
	MIG arc welding (continuous)
○○○○○○	Braze welding
	Anti-corrosion agent application locations (Use access holes to apply liberally to butt-welded joints.)

REPAIR WELDS

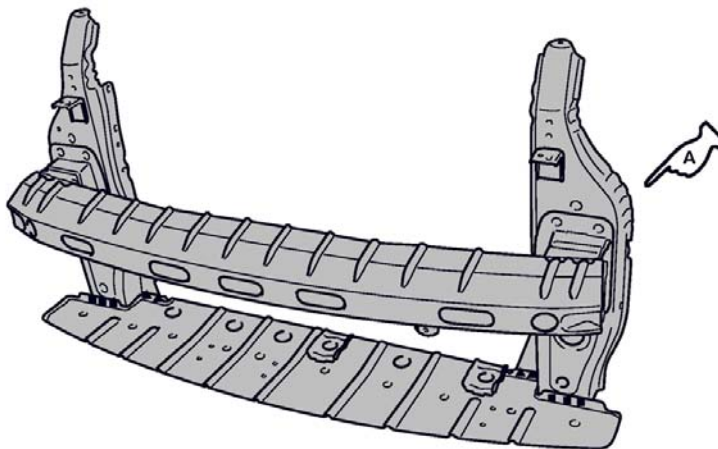

<Revised>

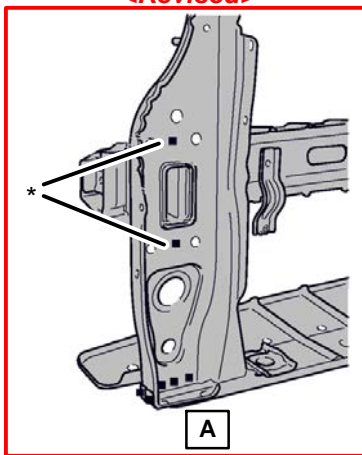

<From TSB-14-42B-002>

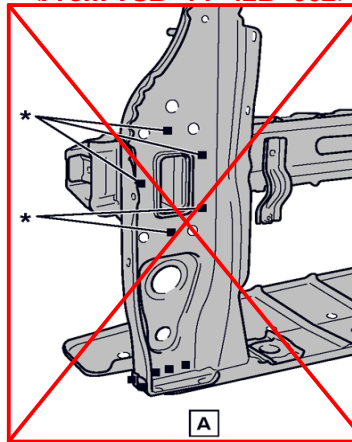

NOTE: *: indicates the welding points of maker joint. (It is not necessary for repair)