

# SB-10055228-4900



Service Information System

Shutdown SIS

Previous Screen

Welcome: chrismk2

< Product: NO EQUIPMENT SELECTED  
Model: NO EQUIPMENT SELECTED  
Configuration: NO EQUIPMENT SELECTED

## Service Letter

### PRODUCT SUPPORT PROGRAM FOR REPLACING THE RING SUPPORT ASSEMBLY ON CERTAIN CT660 ON HIGHWAY TRUCKS

Media Number -TEBE0902-00

Publication Date -21/02/2014

Date Updated -21/02/2014

Caterpillar: Confidential Yellow

TEBE0902-00



## SERVICE LETTER

21Feb2014

U-98  
A-69

*Before/After*

PRODUCT SUPPORT PROGRAM FOR REPLACING THE RING SUPPORT ASSEMBLY ON CERTAIN CT660 ON HIGHWAY TRUCKS

7000

PS44194

NOTE:

This Program must be administered either before or after failure. In either case the decision whether to apply the Program is made by the dealer. When reporting the repair, use "PS44194" as the Part Number and "7755" as the Group Number. If administered before failure, use "56" as the Warranty Claim. chrismk2  
Caterpillar: Confidential Yellow

Description Code and "T" as the SIMS Description code. If administered after failure, use "96" as the Warranty Claim Description Code, and "Z" as the SIMS Description Code.

**NOTE:**

The information supplied in this service letter may not be valid after the termination date of this program. Do not perform the work outlined in this Service Letter after the termination date without first contacting your Caterpillar product analyst.

**TERMINATION DATE**

28Feb2015

**PROBLEM**

The existing ring support assembly can fatigue and break after a short time in service on certain CT660 On Highway Trucks.

**AFFECTED PRODUCT**

Model	Identification Number
*****Group 1*****	
CT660	TKL00100-00106, 108-122, 124-131, 134-136, 138, 145, 147, 149, 151, 155  TRK00103, 107-109, 111-115, 119-120, 122-125, 127-128, 130-131, 133, 136-142, 144-148, 150-151, 153, 155-164, 166-168, 171-174, 176-177, 179, 181-182, 184-186, 190-192, 196-198, 200-202, 204, 206-210, 213, 215-218, 222, 224, 230, 232, 234-235, 240, 247-249, 252-253, 255, 257, 261, 263, 265-266, 271, 275-276, 278, 282, 284, 296, 301, 303, 309, 314, 316, 319, 321, 323, 336-338, 351, 357, 359, 376, 390
*****Group 2*****	
CT660	TGA00001-00086, 88, 90-91, 93-110, 112-116, 119-120, 122, 124-125  TGD00001-00003, 5-9, 101  TGT00100-00107

chrismk2  
Caterpillar: Confidential Yellow

TJS00100
TKL00107, 123, 132, 137, 139-141, 143-144, 146, 148, 150, 152-154, 156-160, 164-165, 168-170, 174-176, 178-183, 188-193, 195-199, 204-206, 208, 210-213, 215-216, 219-220, 224-227, 232-233, 241-243, 255, 257-258, 261, 264-265, 268-269, 274, 277, 282-283, 285, 287, 289-291, 293-295, 298-299, 301, 304, 323, 339, 378, 399, 420, 425, 427, 430, 434-435, 446, 452, 456-457, 461, 463, 465, 471, 478, 502, 543, 545-549, 566, 569-571, 573-587, 589-592, 594-599
TRK00105-00106, 116-118, 121, 126, 129, 132, 135, 143, 149, 152, 154, 165, 170, 175, 178, 183, 187-189, 193-194, 199, 205, 211-212, 214, 219-221, 223, 225-229, 231, 233, 236-239, 241-246, 250-251, 254, 258-260, 262, 264, 267-270, 272-274, 277, 279-281, 283, 286-288, 290-295, 297-300, 302, 304-306, 308, 310-313, 315, 317-318, 320, 322, 324-326, 328, 330, 332-335, 339-344, 346-350, 352-356, 358, 360-375, 377-387, 389, 391-392, 394-411, 413-415, 417-419, 421-422, 424-434, 436-437, 439-442, 444-449, 452-469, 471-477, 479-480, 482-483, 486-491, 493-500, 502, 504, 507-537, 539-549, 551-562, 564-600, 602-611, 613, 615-616, 618, 620-655, 657-664, 666-668, 670-688, 690-710, 712-722, 724-736, 738-744, 746-764, 766-772, 775-779, 781-782, 785-787, 789-816, 818-853, 855-1121, 1123-1237, 1240-1318, 1320-1329, 1331-1336, 1338-1358, 1360-1362, 1367-1368, 1370-1374, 1376-1379, 1381-1458, 1460-1465, 1467-1494, 1496-1515, 1517-1520, 1522-1565
TSY00100

## PARTS NEEDED

Qty	Part Number	Description
*****Group 1*****		
2	3581161	BOLT-HEX
1	3928937	SUPPORT
1	4470832	SUPPORT AS-RING

chrismk2  
Caterpillar: Confidential Yellow

In order to allow equitable parts availability to all participating dealers, please limit your initial parts order to not exceed 23% of dealership population. This is an initial order recommendation only, and the ultimate responsibility for ordering the total number of parts needed to satisfy the program lies with the dealer.

\*\*\*\*\*Group 2\*\*\*\*\*

1	4470832	SUPPORT AS-RING
---	---------	-----------------

In order to allow equitable parts availability to all participating dealers, please limit your initial parts order to not exceed 23% of dealership population. This is an initial order recommendation only, and the ultimate responsibility for ordering the total number of parts needed to satisfy the program lies with the dealer.

## ACTION REQUIRED

Some units have a half clamp design for the charge air cooler (CAC) hold down. These units should fall under Group 1 and will require the extra clamp and bolts. All other serial numbers will be Group 2 and will only require the support bracket.

1. Remove old bracket and install new ring support assembly.
2. Hand tighten new ring support assembly to the engine first.
3. Then hand tighten bolts to ring support assembly.
4. Tighten to 22 to 24 N.M. (16 to 18 ft. lbs).
5. Install hold down clamp. Tighten to 22 to 24 N.M. (16 to 18 ft. lbs).

Note: When the new ring support assembly is installed, there will be more of the fan exposed and the seal will push tighter to the ring. This is normal.

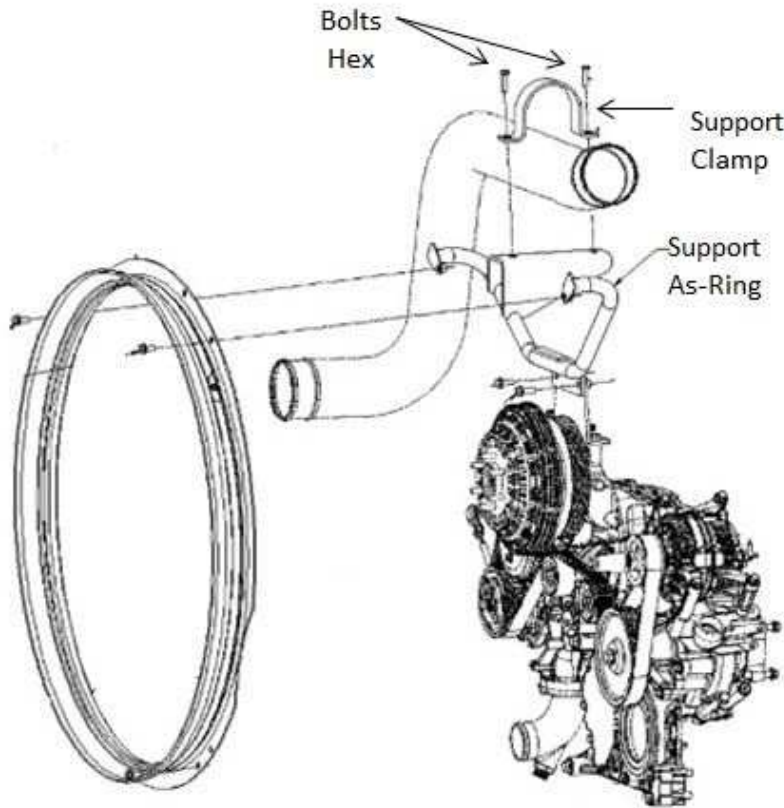

Image1

## SERVICE CLAIM ALLOWANCES

Product smu/age whichever comes first	Caterpillar		Dealer Suggested		Customer Suggested	
	Parts %	Labor Hrs%	Parts %	Labor Hrs%	Parts %	Labor Hrs%
*****Group 1*****						
0-250000 miles, 0-36 mo	100.0%	100.0%	0.0%	0.0%	0.0%	0.0%
NOTE: This is a 0.5-hour job for Group 1						

Product smu/age whichever comes first	Caterpillar		Dealer Suggested		Customer Suggested	
	Parts %	Labor Hrs%	Parts %	Labor Hrs%	Parts %	Labor Hrs%
*****Group 2*****						

chrismk2  
Caterpillar: Confidential Yellow

0-250000 miles, 0-36 mo	100.0%	100.0%	0.0%	0.0%	0.0%	0.0%
NOTE: This is a 0.5-hour job for Group 2						

## PARTS DISPOSITION

Handle the parts in accordance with your Warranty Bulletin on warranty parts handling.

---

[Copyright 1993 - 2014 Caterpillar Inc.](#)  
[All Rights Reserved.](#)  
[Private Network For SIS Licensees.](#)

Wed Mar 5 17:03:03 CST 2014  
 chrismk2

chrismk2  
 Caterpillar: Confidential Yellow