

L83X-A.01.14	To: Official After Sales Network Subject: Installation Of Rubber Boot Onto Alternator Date: 07 th /02/14 Pages: 3	
---------------------	-------------------------------------------------------------------------------------------------------------------------------------------------------------------	-------------------------------------------------------------------------------------

Subject
Installation of rubber boot onto alternator.

Model
All Lamborghini Model Aventador MY 12, 13 and 14 Coupe And Roadster from VIN CLA00091 to VIN ELA02542.

Warning: some vehicles included in this VIN range may not be involved, so check carefully on the Lamborghini WEB Portal (at the section named VIN Info) if the cars in your workshop or in your dealer stock are involved before performing any other operation.

Information to the field

As a result of continuous product monitoring, Automobili Lamborghini Spa has found on some vehicles external corrosion on the alternator positive pole fastener.

Field solution

Ad a rubber protection boot to the cable.

Spare Parts

P/N	Description	Q
470915521	Protective rubber boot	1

Warranty Claim data

The warranty reimbursement request for this rework action will be managed by the following standard Warranty Claim procedures.

A. Aventador MY 2012

Campaign Code: L83X-A.01.14
Campaign Des.: Installation of rubber boot onto alternator
Cost code: 50
Component code: CCA0114
Trouble code: 220
Labor code: CCA0114100
Labor Time: 0,5 h

B. Aventador MY 2013 and 2014

Campaign Code: L83X-A.02.14
Campaign Des.: Installation of protective rubber boot onto alternator positive pole
Cost code: 50
Component code: CCA0214
Trouble code: 220
Labor code: CCA0214100
Labor Time: 0,7 h

Remember to fill all data in the section “Service and Recall Campaign” in the Warranty booklet of the vehicle as shown below.

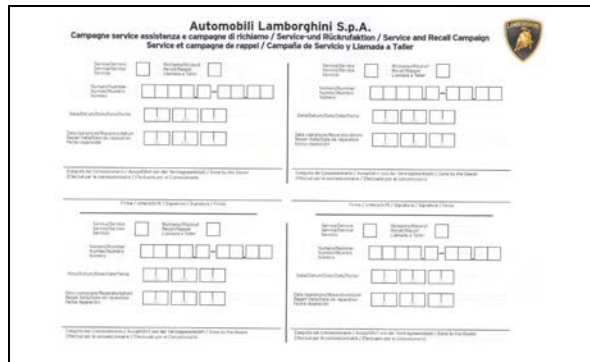

Necessary material:

Aventador MY 2013 and followers:
Super-capacitor Charge and Discharge tool (p/n. 69195291)



Instructions

1. Procedure for battery disconnection.
 - a. Aventador MY2012
Disconnect the positive fastener onto battery following the instructions reported in work shop

Rev.01	The information and procedures published below are strictly confidential and intended exclusively for authorized operators and individuals. All copyrights are the property of Automobili Lamborghini S.p.A based on copyright law. The company reserves the right to make updates and modifications. The reprinting, reproduction, forwarding to unauthorized people and/or to third parties and partial or entire translation thereof are prohibited without written authorization from Automobili Lamborghini S.p.A. <div style="text-align: right; font-size: small;">doc. nr: L/V6_M06 Rev.[02]</div>	1/3
--------	---------------------------------------------------------------------------------------------------------------------------------------------------------------------------------------------------------------------------------------------------------------------------------------------------------------------------------------------------------------------------------------------------------------------------------------------------------------------------------------------------------------------------------------------------------------------------------------------------------------	-----



manual Aventador MY 2012 (chapter 09 electrical system □ 15 Battery □ Battery □ Disassembly/Assembly)

b. Aventador MY2013 and 2014:

WARNING: open driver's door before disconnecting battery.

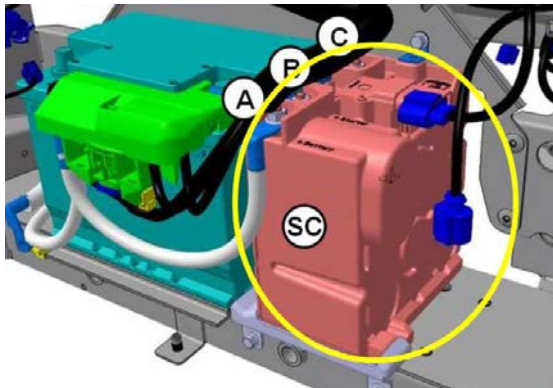

WARNING: Super-capacitor on board

Super-capacitor module supply energy necessary for engine start up while battery feeds the rest of electronic/electrical platform.

The device presents a high electrical charge.



RISK OF ELECTROCUTION

Before disconnecting battery positive pole it is mandatory to discharge the Super-Capacitor with the specific tool (p/n 69195291).

Work scrupulously as in Aventador2013 workshop manual (Chapter 09 Electrical system → 15 Battery → Battery → Description → Procedure for Super-Capacitor Draining).

Once Super-Cap discharge procedure is completed, control that the tool displays a voltage under 0,5 V

2. Remove trunk pool to get access to battery.
3. Unscrew fastener bolt onto positive pole

Torque: **6 Nm**

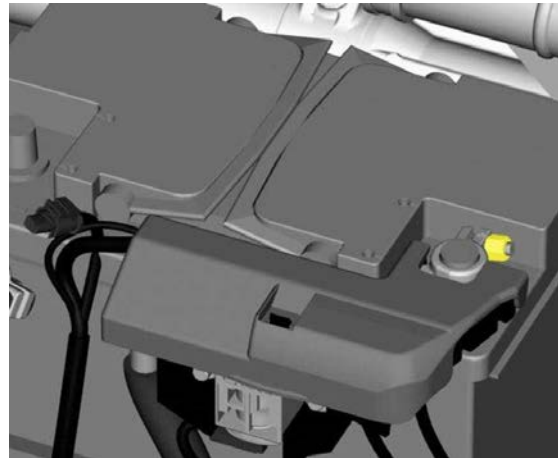

4. Loose positive pole terminal on battery.

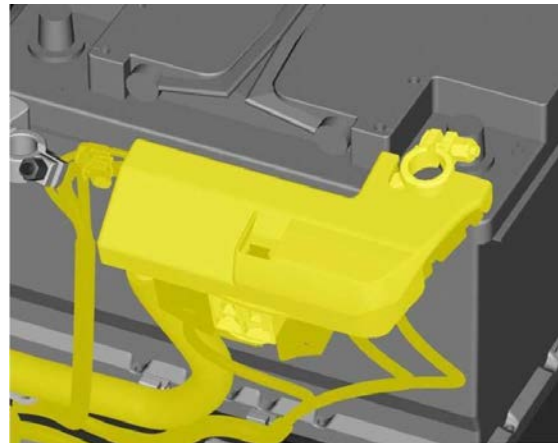

5. Open engine bonnet and remove engine bay rear finishing panel.

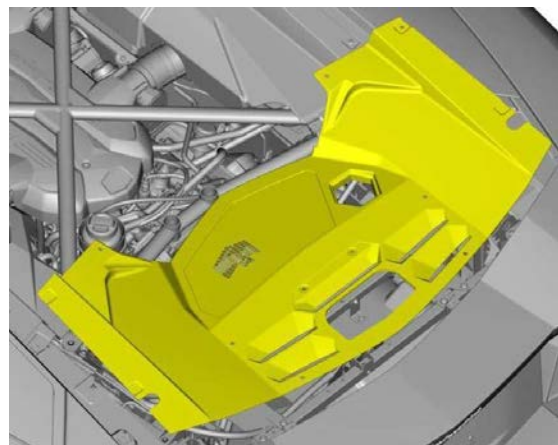

6. Remove nut that secure alternator positive cable.



7. Fit rubber hood.

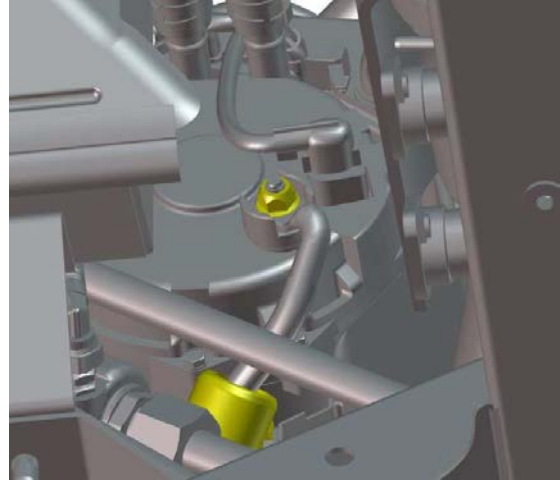

9. Let rubber cup fit well with nut as shown

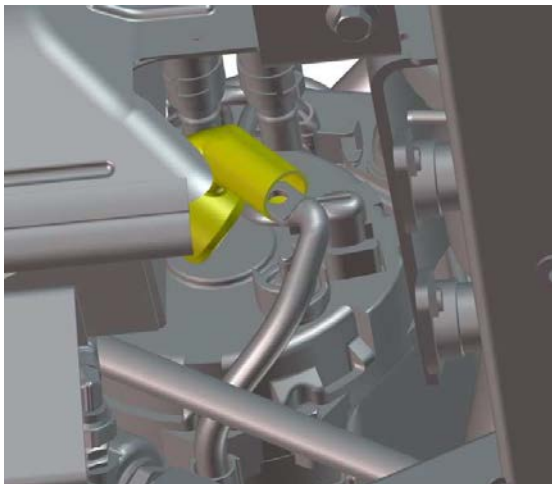

8. Place correctly the cable and fasten the nut

Apply on nut protective wax AKR 392 110 21
EIW

Torque: 20 Nm

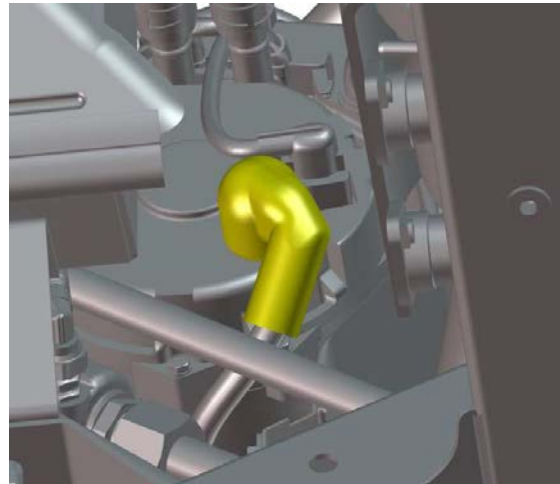

10. Reassembly engine bay rear finishing panel.

11. Reconnect battery positive pole.

12. Charge Super-Cap (chapter 09 Electrical system → 15 Battery → Battery → Description → Procedure Super-Capacitor draining).