

SB-10054683-8953



Countries:	CANADA, COLOMBIA, UNITED STATES, PUERTO RICO	Document ID:	IK1201039
Availability:	ISIS, FleetSIS, Body Builder	Revision:	1
Major System:	ENGINES	Created:	11/26/2013
Current Language:	English	Last Modified:	6/11/2014
Other Languages:	NONE	Author:	James Santos
Viewed:	589		

[Less Info](#)

Hide Details

Coding Information

Copy Link 	Copy Relative Link 	Bookmark View My Bookmarks	Add to Favorites 	Print 	Provide Feedback 	Helpful 7	Not Helpful 1
----------------------	-------------------------------	--	-----------------------------	------------------	-----------------------------	-------------------------	-----------------------------

Title: Aftertreatment Purge Air Valve Air Supply Line Routing for both Cummins ISX SCR Engines and N13 with SCR Engines

Applies To: ProStar, TransStar , PayStar, 9900i. ISX Cummins SCR, N13 SCR

DESCRIPTION

Proper AFT Purge Valve air line routing.

POSSIBLE FAULT CODES

SPN 3490 FMI 7
Cummins Fault 3225

SERVICE PROCEDURE

N13 with SCR

The engine air supply is run directly from the manifold on a Bendix AD-IS dryer, used in all ProStars, and off the secondary air tank on all other units not equipped with the AD-IS dryer. Both configurations are shown below. The line runs up the driver side frame rail where it T's off to the Aftertreatment Purge Air Valve, continuing on to a reducer fitting just below the valve cover on the driver side, from here it runs around the front of the engine to supply air to the Air Control Valve (ACV).

We have identified two types of concerns on N13 engines

- Missing T fitting and short 1/4" air line to Aftertreatment Purge Air valve
- Missing complete engine air supply line - In this case you will need plumb air from either the auxiliary manifold found on the AD-IS dryer, or from the secondary air tank pressure protection valve used with all other dryer types

Engine Air supply - Bendix AD-IS Dryer - N13 with SCR

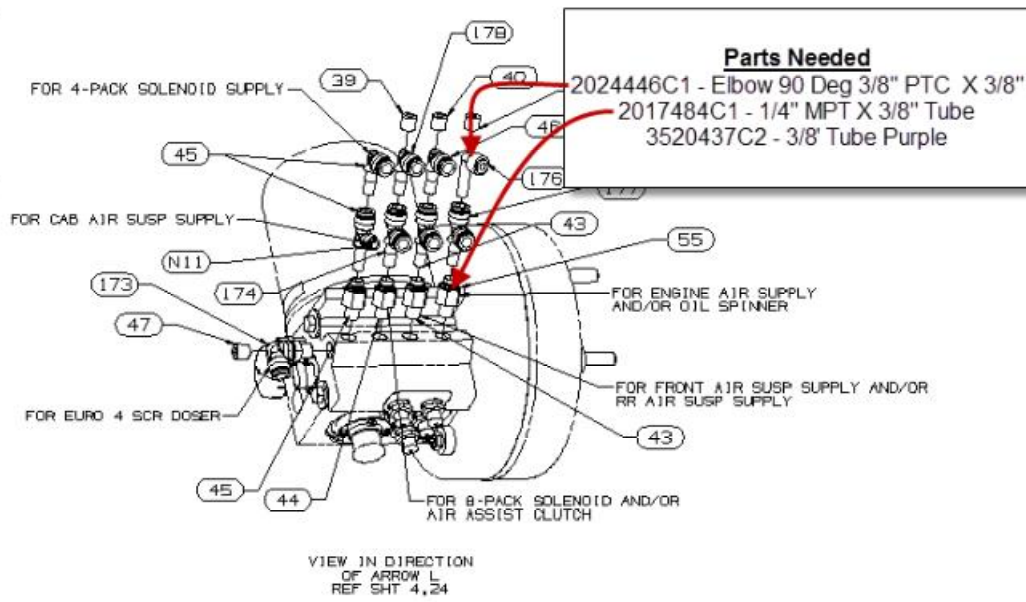

All other dryers air supplied to engine from secondary air tank pressure protected valve - N13 with SCR

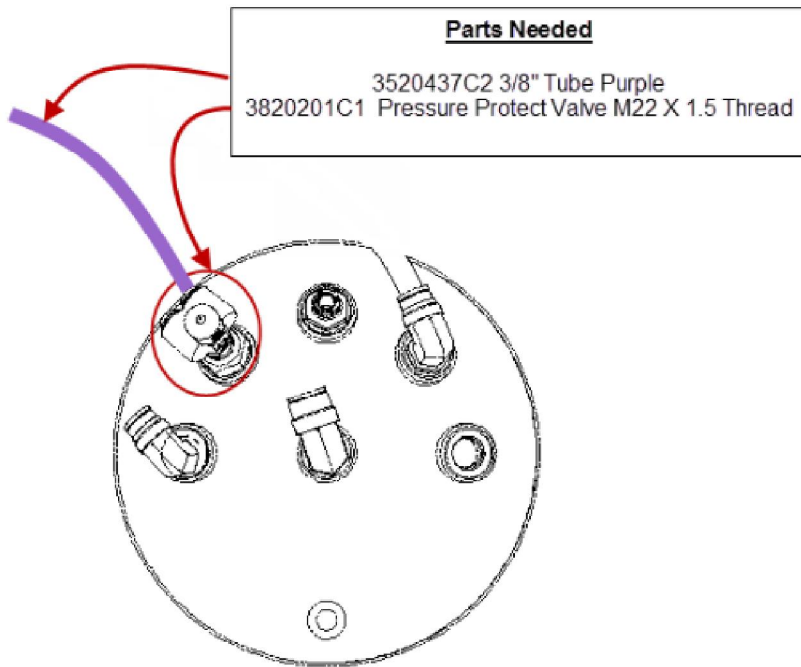

352

Parts and Routing info for Missing T fitting and short 1/4" tube - N13 with SCR

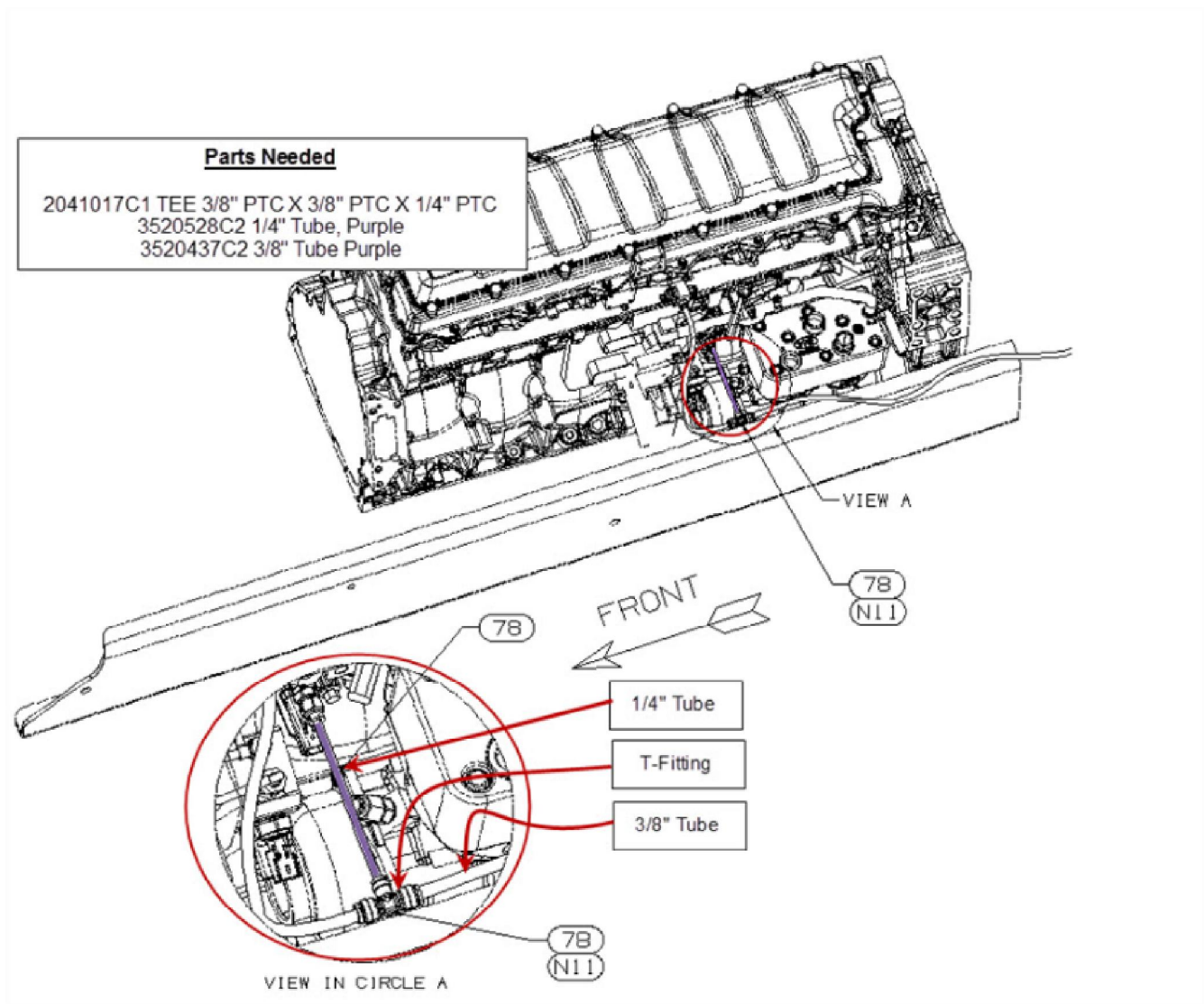

Parts Information N13 with SCR

Part Number	Description
202446C1	Elbow 90 Deg 3/8" PTC X 3/8"
2017484C1	1/4" MPT X 3/8"
3820201C1	Pressure Protect Valve M22 X 1.5 Thread
2041017C1	TEE 3/8" PTC X 3/8" PTC X 1/4" PTC
3520437C2	3/8" Tube, Purple
3520528C2	1/4" Tube, Purple

Cummins ISX 15L with SCR

Since the ISX does not have an ACV the only concern we have seen on this application is that complete line is missing from the either the auxiliary manifold (AD-IS Dryer) or the secondary air tank pressure protection valve (all other dryers). Both configurations are shown below.

Engine Air supply - Bendix AD-IS Dryer Cummins ISX

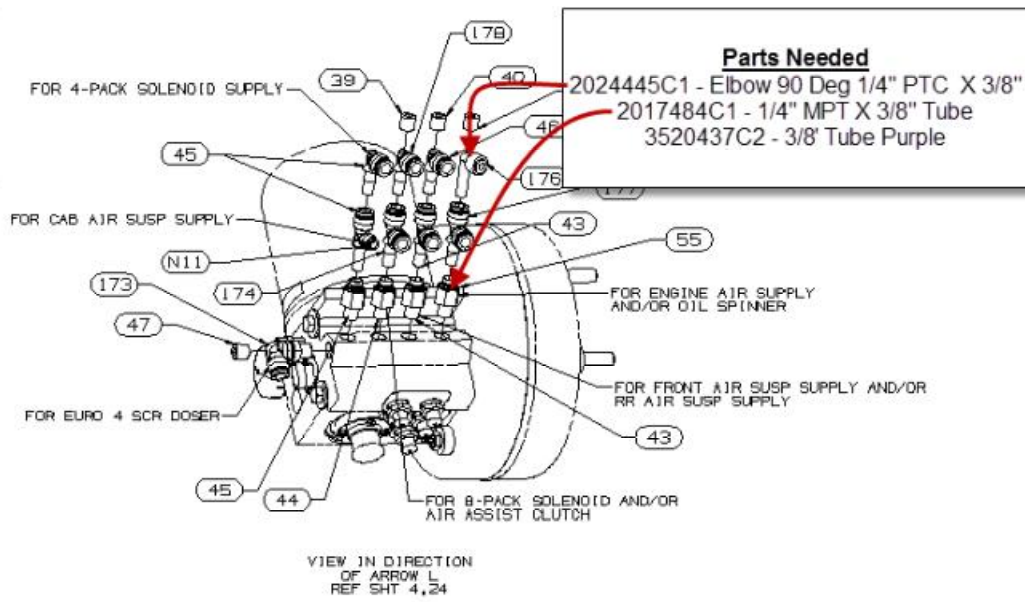

All other dryers air supplied to engine from secondary air tank pressure protected valve - Cummins ISX with SCR

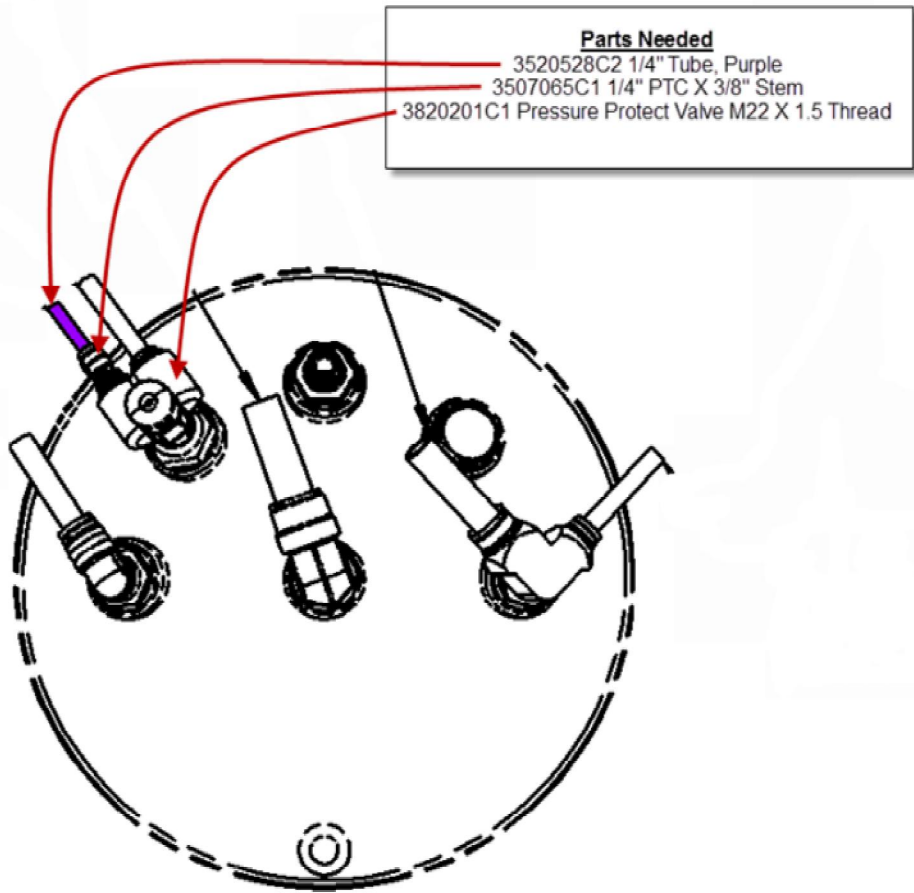

Parts and Routing information for missing engine supply line and fitting - Cummins ISX with SCR

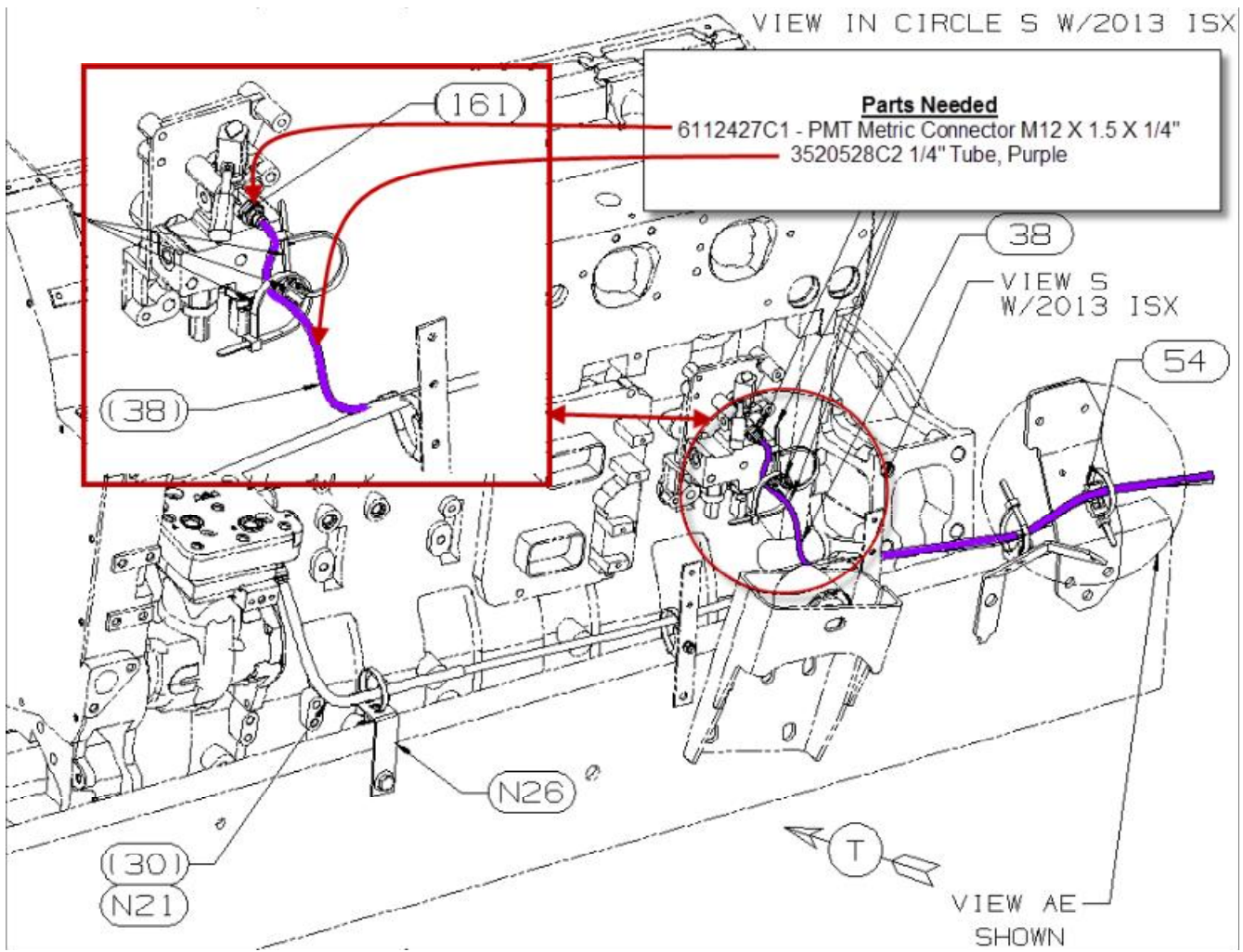

Parts Information Cummins ISX with SCR

Part Number	Description
2024445C1	Elbow 90 Deg 1/4" PTC X 3/8"
2017484C1	1/4" MPT X 3/8"
3820201C1	Pressure Protect Valve M22 X 1.5 Thread
3507065C1	1/4" PTC X 3/8" Stem
3520528C2	1/4" Tube, Purple

Hide Details

Feedback Information

Viewed: 588
 Helpful: 7
 Not Helpful: 1

No Feedback Found