



Applies To: **2005 Civic** – Check the iN VIN status for eligibility
2005 Civic Hybrid – Check the iN VIN status for eligibility
2005 Civic GX – Check the iN VIN status for eligibility

November 5, 2013

Voluntary Driver's Airbag Study

BACKGROUND

American Honda is conducting a study of driver airbag inflators from selected vehicles. With customer's consent, remove the airbag module, inspect the inflator and, if the customer has a Takata inflator, replace the airbag inflator. The driver's airbag inflator will be sent to Takata.

American Honda is contacting customers of eligible vehicles to bring their vehicles in for inspection. However, if a customer of an eligible vehicle arrives at your dealership for service, please inquire if the customer would allow your dealership to inspect the vehicle.

If the customer agrees to participate in this study, order a replacement airbag inflator through the controlled parts system. To avoid inconveniencing the customer, it may be necessary to request overnight shipping if the part is not available from your facing parts center. If the customer needs a rental, American Honda will cover a rental car for one day to help reduce any customer inconvenience.

This is a voluntary action, not a campaign. **You must have the customer's permission before replacing any components on eligible vehicles**, because replacing any part without the customer's permission is illegal. After the study is complete, this bulletin will be discontinued.

PARTS INFORMATION

Driver's Airbag Inflator (includes inflator, four locknuts, and two Torx bolts):

P/N 04770-S5A-308

Torx Bolts (each bag contains two bolts):

P/N 90134-S04-A81

TOOL INFORMATION

KTC Trim Tool Set: TSOJATP2014

WARRANTY CLAIM INFORMATION

OP#	Description	FRT
7521G8	Remove the driver's airbag module. If the inflator is made by Autoliv, reinstall the original airbag module. NOTE: Use new Torx bolts to reinstall the Autoliv airbag.	0.3
7521G9	Remove the driver's airbag module. If the inflator is made by Takata, REPLACE the airbag inflator.	0.5

Failed Part: P/N 06770-S5A-A10ZA

Defect Code: 5KT00

Symptom Code: JC700

Skill Level: Repair Technician

INSPECTION/REPLACEMENT PROCEDURE

NOTE: Do not deploy the airbag inflator. Return it to Takata by following the shipping instructions included with the new inflator.

1. Make sure you have the audio or navigation unit anti-theft code before starting work.
2. Disconnect the negative battery cable, and wait at least 3 minutes before beginning work.
3. Remove the access panel from the steering wheel, then disconnect the driver's airbag 4P connector from the cable reel.

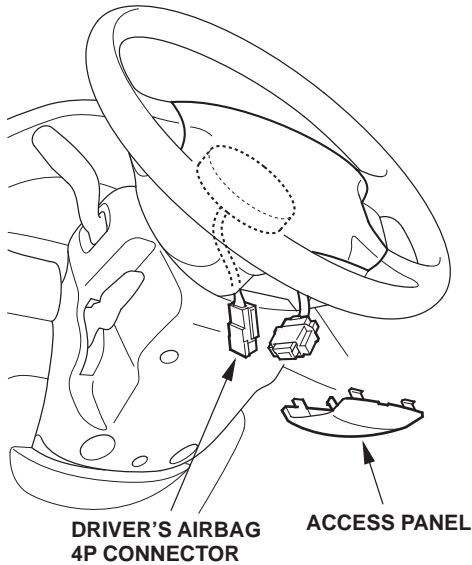

4. Remove the two Torx bolts using a Torx T30 bit, then remove the driver's airbag.

TORX BOLTS
9.8 N·m (7.2 lb-ft)
Replace.

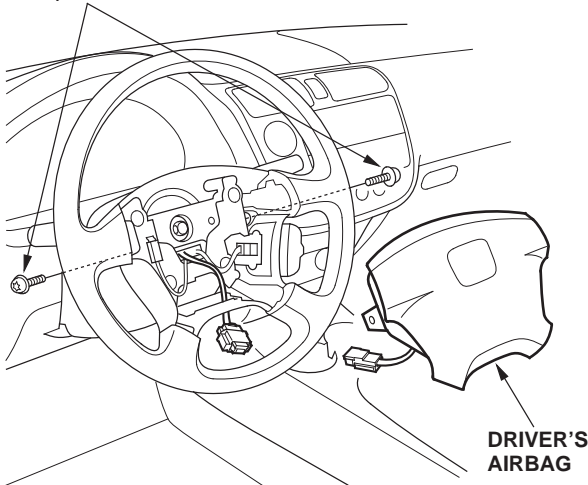

5. Compare the airbag to the images below to determine if the inflator is made by Autoliv or Takata.
 - If the airbag is made by Takata, go to step 6 to replace the inflator.
 - If the airbag is made by Autoliv, the airbag is not part of the study. Go to step 12–16 to reinstall the airbag **using new Torx bolts**.

TAKATA



AUTOLIV (not involved)

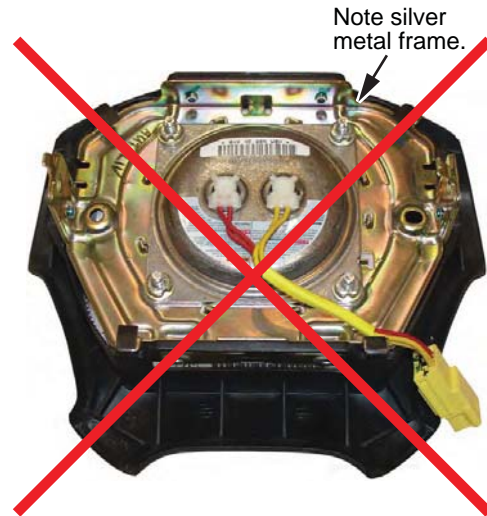

- Write down the 13-digit serial number located on the right side of the new inflator's box. Your warranty clerk must enter this 13-digit serial number in the Diagnostic Trouble Codes field on the warranty claim.

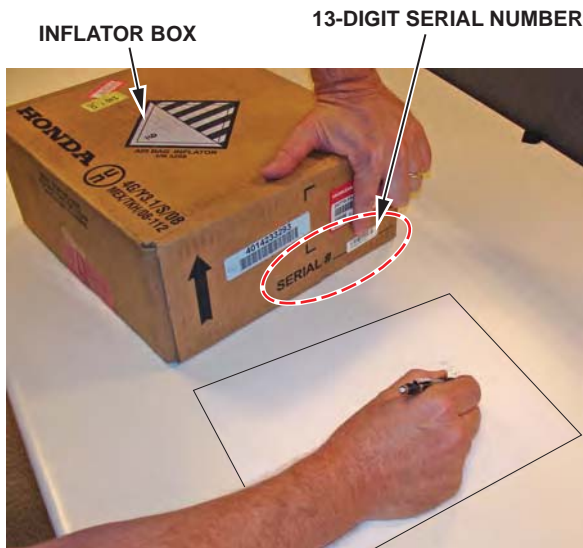

- Place the airbag, face down, on a clean shop towel.
- Using needle-nose Vise Grips, remove the four locknuts from the inflator. They will not be reused.
NOTE: Do not remove the inflator from the airbag until you complete step 9.

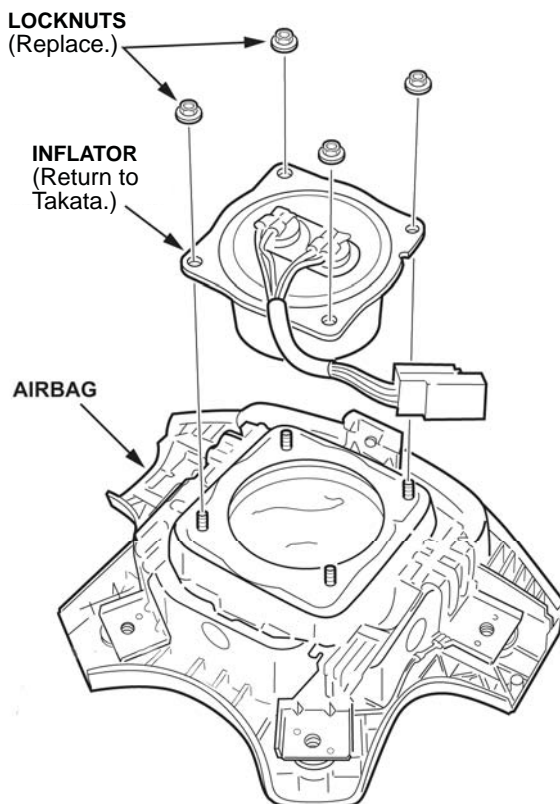

- Use shop air to clean any debris that may be on the inflator, then remove the inflator from the airbag.

NOTE:

- Do not allow any foreign objects to enter the inflator opening in the airbag.
- Do not deploy the inflator. The inflator must be returned to Takata in the box the new inflator came in. Refer to the instructions included in the new inflator box.

- Turn over the airbag (inflator side down), and shake it to remove any debris from the inflator opening.
- Install the new inflator in the airbag with new locknuts. Torque the locknuts to **3.9 N•m (2.8 ft-lb)**.
NOTE: The replacement airbag inflator is slightly taller than the original, but they are interchangeable.
- Place the driver's airbag in the steering wheel, and secure it with new Torx bolts. Torque the Torx bolts to **9.8 N•m (7.2 ft-lb)**.
- Connect the cable reel to the driver's airbag 4P connector, then install the access panel on the steering wheel.
- Connect the negative battery cable.
- After installing the airbag, confirm proper system operation by turning the ignition switch to ON (II) and making sure the SRS indicator goes off after about 6 seconds.
- Enter the anti-theft code.
- Return the undeployed inflator to Takata using the return instructions included in the box.