

SB-10044680-4717



SI M11 01 12
Engine

January 2013
Technical Service

This Service Information bulletin supersedes SI M11 01 12 **dated June 2012.**

NEW designates changes to this revision

SUBJECT

Engine Oil Leak

MODEL

R55 (Cooper Clubman and Cooper S Clubman) with N16 and N18 engine

R56 (Cooper and Cooper S) with N16 and N18 engine

R57 (Cooper and Cooper S Convertible) with N16 and N18 engine

R58 (Cooper Coupe and Cooper S Coupe) with N16 and N18 engine

R59 (Cooper Roadster and Cooper S Roadster) with N16 and N18 engine

R60 (Cooper Countryman and Cooper S Countryman) with N16 and N18 engine

SITUATION

The customer states that a small engine oil leak can be seen from the underside of the engine.

CAUSE

The internal sealing of the oil pump volume control solenoid valve is compromised, allowing engine oil to leak from the oil pump volume control solenoid.

PROCEDURE

Below is the procedure for identifying how far the engine oil has migrated inside the engine electrical harness, if at all. The procedure must be followed very carefully so that the proper repair is identified.

1. Disconnect the oil pump volume control solenoid valve electrical connection per Repair Instructions 11 41 519 "Removing and installing or replacing the solenoid valve (engine oil pump)."

Inspect the electrical connector; if no engine oil is found inside the electrical connector, replace the oil pump volume control solenoid valve only. See Repair Instructions 11 41 519. If engine oil is found inside the electrical connector, proceed to step 2.

2. Remove the cover from the DME and remove all three electrical connectors from the DME. Inspect the connectors for traces of engine oil. If no engine oil is found, replace the oil pump volume control solenoid valve and the engine section of wire harness. Refer to EPC for the additional part number.

If engine oil is found in the DME connector, proceed to step 3.

3. If engine oil is found in the DME electrical connector, replace the oil pump volume control solenoid valve, the engine section of the wire harness and the DME. Refer to EPC for the additional part numbers.

4. **NEW** The replacement engine oil pan gasket available via EPC (P/N 11 13 7 565 928) should no longer be used when resealing the engine oil pan. A substitute flexible liquid sealing material, P/N 83 19 0 404 517 Loctite 5970, should be used.

NEW Before reinstalling the engine oil pan, it must be cleaned of all adhesive residues. Apply Loctite 5970 (P/N 83 19 0 404 517) to the sealing surface of the engine oil pan. The bead of the flexible liquid sealer should be approximately 2mm-2.5mm in height when applied. The sealing material should be applied to the engine oil pan on the inboard side of the drilled fastener holes. Refer to the illustration below for proper flexible liquid sealer location. For proper tightening torque and vehicle reassembly procedures, refer to Repair Instruction 11 13 000, “Removing and installing engine oil pan.”

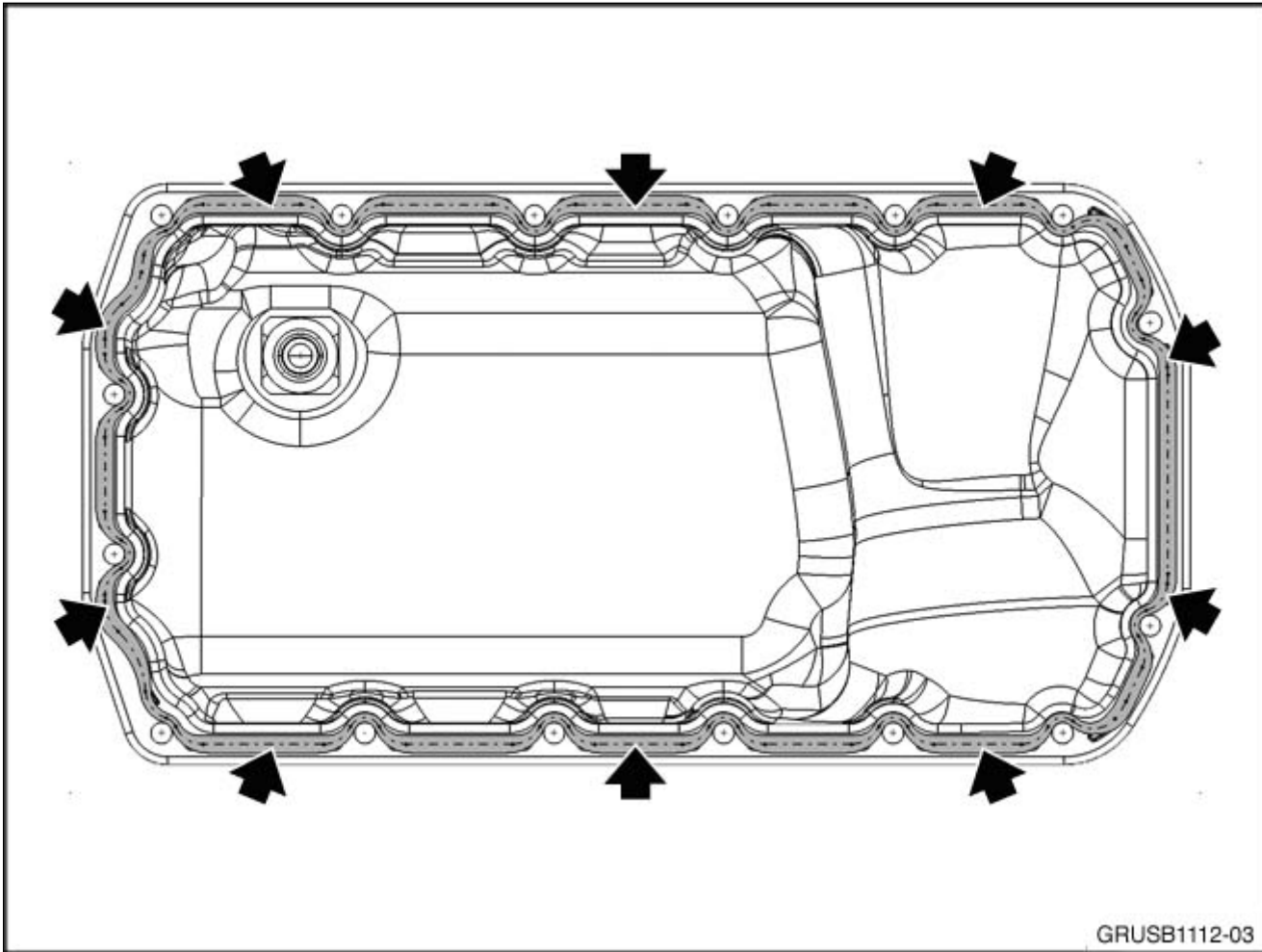

NEW Note: If the ISTA system message displays: “Battery voltage only “XX.XX” V. Please connect charger,” connect an approved charger and note the displayed battery voltage reading in the repair order comments section.

PARTS INFORMATION

Part Number	Description	Quantity
11 41 7 585 446	Solenoid valve (SOLV)	1
83 19 0 404 517	Loctite 5970	1

Refer to EPC, using the VIN of the vehicle for the engine section of wire harness and the DME, as necessary.

Do not replace the engine oil pump.

WARRANTY INFORMATION

NEW Covered under the terms of the MINI New Passenger Car Limited Warranty or the MINI NEXT Certified Pre-Owned Limited Warranty.

NEW Specific eligible repairs **may** also be covered by the terms of the Federal, State or MINI Emissions Warranty.

NEW To determine if any **applicable** Federal, State or MINI Emissions Warranty coverage applies **prior** to performing repairs, please see SI M01 03 11 for “Emissions Warranty Coverage” and refer to the “Glossary of Emission Coverage” attachment for more information.

NEW The MINI NEXT Certified Pre-Owned Limited Warranty applies to MINI NEXT vehicles that are still within the MINI NEXT coverage period, but beyond the Emissions Warranty coverage that applies.

Defect Code: 11 41 09 48 00

A. Inspecting connectors and replacing only the oil pump assembly with volume control solenoid valve (Procedure Step 1)

Labor Operation:	Labor Allowance:	Description:
11 99 000	3 FRU	Work time to identify the source of the engine oil leak (Main work)
or		
11 99 000	1 FRU	Work time to identify the source of the engine oil leak – vehicle already in the workshop (Plus work)
and		
11 41 519	Refer to KSD	Replacing solenoid valve for oil pump (includes draining and refilling the engine oil)

If the Check Engine Light is illuminated, see Item “D” for additional work.

And if necessary, also:

B. Inspecting connectors, replacing the oil pump assembly with volume control solenoid valve and the engine section of the wire harness (Procedure Steps 1 and 2)

Labor Operation:	Labor Allowance:	Description:
12 51 501	Refer to KSD	Replacing engine section of wire harness

And if necessary, also:

C. Inspecting the connectors, replacing the oil pump volume control solenoid valve, the engine section of wire harness and the DME control unit (Procedure Steps 1-3)

Labor Operation:	Labor Allowance:	Description:
12 14 550	Refer to KSD2	Replacing control unit (DME)
and		
61 00 710	Refer to KSD2	Programming / encoding control unit(s) (not including CAS)
or		
61 00 720	Refer to KSD2	Programming / encoding control unit(s) (with CAS)

NEW If the “Vehicle Test” was **not** required and claimed as part of Item “A,” claim the Vehicle Test (Item “D” below) with this procedure when replacement of DME is required.

D. Performing the “Vehicle Test” (with vehicle diagnosis system: checking faults)

Labor Operation:	Labor Allowance:	Description:
00 00 556	Refer to KSD2	Performing “vehicle test” (with vehicle diagnosis system – checking faults)
and if necessary, also		
61 21 528	Refer to KSD2	Charging battery (See the MINI Cooper S Countryman SX below)

NEW Note: When the ISTA system message displays: Battery voltage only “XX.XX” V. Please connect charger. Please note the displayed battery voltage reading in the repair order comments section. This documentation is not necessary when part of an approved Technical Service repair procedure; the battery charger is required to be attached before performing the Vehicle Test. Also see charging battery below.

NEW Refer to KSD2 for the corresponding flat rate unit (FRU) allowance. Enter the Chassis Number, which consists of the last 7 digits of the Vehicle Identification Number (VIN). Click on the “Search” button, and then enter the applicable flat rate labor operation in the FR code field.

NEW Sublet – Sealing Oil Pan

Sublet Code 4:	See sublet reimbursement calculation below	Reimbursement for Loctite 5970 (MINI P/N 83 19 0 404 517: do not use this part number for claim submission).
----------------	--	--

Sublet calculation: MINI P/N 83 19 0 404 517 -- quantity one at dealer net plus handling. Enter this material cost in sublet and itemize the amount in the claim comment section.

MINI Cooper S Countryman SX (R60:All-wheel drive)

The time allowance for flat rate labor operations 11 41 519 and 12 51 501 both include labor time for “removing and installing the transfer box.” Please see the KSD2 “FR Description” section for more information.

To offset the overlapping labor, when labor operations 11 41 519 and 12 51 501 are both claimed, labor operation 12 51 501 will be reduced automatically when the claim is credited to an “adjusted 18 FRU time allowance.” Please

invoice the FRU time allowances on your repair order accordingly.

Labor Operation:	Labor Allowance:	Description:
11 41 519	Refer to KSD2	Replacing solenoid valve for oil pump (includes draining and refilling the engine oil)
and		
12 51 501	18 FRUs	Replacing engine section wire harness with the replacement of the oil pump solenoid valve (adjusted time allowance)

Charging Battery

The MINI Cooper S Countryman SX time allowance for flat rate labor operations 11 41 519 and 12 51 501 both include labor time for “Charging Battery.” If one or both of these labor operations are required along with “Charging Battery,” please do not claim labor operation 61 21 528 separately. See the KSD2 “FR Description” section for more information.

[MINI, a division of BMW of North America, LLC
Copyright © 2013 BMW of North America, LLC]