

SB-10044293-5968



Countries:	CANADA, COLOMBIA, UNITED STATES, MEXICO, PUERTO RICO	Document ID:	IK0800219
Availability:	ISIS, Bus ISIS, FleetISIS, Body Builder	Revision:	5
Major System:	ELECTRICAL SYSTEM	Created:	2/22/2010
Current Language:	English	Last Modified:	8/29/2014
Other Languages:	NONE	Author:	Joe Christopher
Viewed:	7479		

[Less Info](#)

Hide Details

Coding Information

Copy Link 	Copy Relative Link 	Bookmark View My Bookmarks	Add to Favorites 	Print 	Provide Feedback 	Helpful 154	Not Helpful 137
----------------------	-------------------------------	--	-----------------------------	------------------	-----------------------------	---------------------------	-------------------------------

Title: Accelerator Position Sensor/IdleValidation Switch APS / IVS Diagnostics NavPak™, CEC equipped engine control systems

Applies To: All NavPak™, CEC equipped engines 1998 through 2003, including T444E, DT466E and 530E engines. Vehicles included, but not limited to, would be: 2000,3400,3800,4000FBC,4000 8000, 4300,4400,7400,7500, 8500, CE Bus,RE Bus, FE Bus 1552 and 1652 SC, SFC Commercial Chassis, and 5000 vehicles.

Dealers: Please refer to the change log text box below for recent changes to this article:

- 8/29/2014 - Corrected tool image for 6 pin break out tee
- 5/19/2014 - Corrected tool number for 6 pin break out tee

DESCRIPTION

Two new APS sensors (Accelerator Position Sensor) have been developed and released for use with pre-2010 emissions International Engines. The new sensors listed below contain "non-contact" hall-effect idle validation sensors. This replaces the open/closed IVS switches in the old sensors . As a result of this new design, the normal resistance measurements performed for the potentiometer and idle validation switch on the previous "contact" sensor are no longer applicable. A technician can continue to perform resistance measurement tests on the engine harness with the sensor unplugged (open circuit), but should rely solely upon the voltage measurement tests, with a breakout harness installed, at the ECM and APS sensor, and the new sensor connected.

SYMPTOMS

- APS/ IVS fault codes
- Engine speed restricted to idle
- Erratic automatic transmission operation
- Engine warning lights illuminated

POSSIBLE DIAGNOSTIC TROUBLE CODES

T444E, DT466E, 530E, NavPak™ equipped vehicles

DTC	MODULE	DESCRIPTION
131	ECM	APS signal voltage out-of-range LOW . < 0.147 V for more than 0.35 seconds.
132	ECM	APS signal voltage out-of-range HIGH. > 4.55 V for more than 0.35 seconds.
133	ECM	APS signal in-range fault.
134	ECM	APS and IVS disagree.
135	ECM	Idle validation switch circuit fault

[PARTS](#)

INFORMATION

Please refer to TSI letter 10-08-01 for parts details including cross reference information.

Follow link https://evaluate.internationaldelivers.com/service/tsis/100801_1.xml

DIAGNOSTICS

There can be various conditions that can cause APS/IVS related issues. As with any performance related fault, a thorough description of the issue, from the operator is critical.

- Is the fault sensitive to road conditions, such as rough terrain, hills, etc ?
- Is the fault temperature sensitive ?
- Does the fault occur, when coming to a stop, or when accelerating or cruising ?
- Do any other faults occur at the same time, such as loss of dash cluster, or other in cab accessories ?
- Are there faults regarding the IAT (intake air temperature) sensor, BAP(barometric air pressure sensor)?

If any circuit issues are suspected, a thorough visual inspection of all circuitry for shorts, and opens is critical, as intermittent issues are usually caused by wiring faults. Any harness mounting points should be disassembled and inspected. Where harnesses pass by sharp edges, or possible points of abrasion should be inspected and if required, repaired. On 4300, 4400, 7300, and 7400, DT466E/530E , NavPak™ ECM equipped, vehicles chassis' several common harness contact points have been noted. The harness passes by the drivers side edge, of the doghouse opening in the firewall. The harness runs very close to this area, and can cut, and short the harness. At the left rear of the engine valve cover, is a P-clamp mounting of the harness. This clamp, and the surrounding mounting area, can cause harness abrasion, and shorting. The harness is long enough, in these areas, to be relocated, after the repair, to prevent recurrence.

On T444E, DT466E and 530E NavPak™ ECM equipped chassis', when inspecting the ECM connector, remove the orange rubber seal, located in the ECM, being careful to not damage/bend any pins. This seal can mask evidence of corrosion in the ECM. Removal of the red locks in the ECM connector, for thorough terminal inspection, is also recommended.

Whenever connector inspection has been performed, and tested satisfactory, always apply a light coating of dielectric grease upon reconnection, being careful to properly lock connectors.

On 2000,3400,3800,4000FBC,4000 and 8000 models, the metal pedal assemblies can wear over time, causing a timing issue between the APS and the IVS signals. A worn pedal can often be tested by pulling up on the accelerator pedal, with the ignition switch on. If faults codes become active, the pedal assembly is most likely the cause.

If idle validation faults are an issue, testing the ignition voltage supply to the sensor should be performed. Opens, short, corrosion, etc. can interfere with the IVS operation.

COMPONENT/FUNCTION DESCRIPTION

The Accelerator Position Sensor (APS) is a potentiometer sensor. When the APS receives a 5V reference signal and a ground from the Electronic Control Module (ECM), a linear analog voltage signal will indicate a demand for power.

The Idle Validation Switch (IVS) provides 0 or 12 Volts to the ECM as a signal to verify the pedal idle position.

Fault Detection and Management

Detected malfunctions of the APS or IVS sensor circuit will illuminate the WARN ENGINE lamp.

If the ECM detects an APS signal Out of Range High or Out of Range Low, the engine will ignore the APS signal and operate at low idle.

When differences between IVS and APS are detected, the ECM sets an IVS Diagnostic Trouble Code and limits the APS command to 50%.

If differences between the IVS and APS are detected, but the ECM cannot discern an APS or IVS Diagnostic Trouble Code, the engine will operate at low idle only.

Extended Description

International® electronic engines use an electronic accelerator pedal assembly that includes an Accelerator Position Sensor (APS) and an Idle Validation Switch (IVS). The APS and IVS are integrated into one component mounted on the accelerator pedal. The accelerator pedal assembly is serviceable to the extent that the APS/IVS switch can be replaced without replacing the complete assembly.

Accelerator Position Sensor (APS)

The ECM sends a regulated 5V signal through the ECM black chassis connector terminal 3 to APS connector terminal C. The APS returns a variable voltage signal (depending on pedal position) from the APS connector terminal A to the ECM at terminal 8. The APS is grounded from connector terminal B to the ECM signal ground terminal 11.

APS Auto-Calibration

The ECM determines the lowest and highest pedal positions by reading and storing the minimum and maximum voltage levels from the APS. In this manner the ECM auto-calibrates the system for maximum pedal sensitivity. The ECM auto-calibrates when the key is ON, but when the key is OFF, these values are lost. When the key is ON again, this process starts over. When the pedal is disconnected (or new one installed), the pedal does not need calibration, since calibration happens when the key is ON.

Idle Validation Switch (IVS)

The ECM expects to receive one of two signals through the ECM black chassis connector (terminal 27) from APS/IVS connector terminal D:

- 0V when the pedal is in the idle position.
- 12V when the pedal is depressed.

The Idle Validation Switch receives 12V voltage from the ignition fuse. When the pedal is not in the idle position (throttle applied), the IVS supplies a 12V signal to the ECM.

The ECM compares APS/IVS inputs at terminals 8 and 27 to verify that the pedal is in the idle position. If the APS signal at terminal 8 indicates throttle is being applied, the ECM expects to see 12V at IVS terminal 27. If the APS signal at terminal 8 indicates idle, the ECM expects to see 0V at the IVS terminal 27.

ECM Diagnostics

When the ignition is ON, the ECM continuously monitors the APS/IVS circuits for expected voltages. The ECM also compares the APS and IVS signals for differences. If the signals are not what the ECM expects to see, the ECM sets Diagnostic Trouble Codes.

TROUBLESHOOTING

NOTE:

When performing diagnostic tests, be sure to refer to the correct circuit diagram manuals, found on ISIS, for the vehicle you are working on. If working on a vehicle built before October 1, 1998, you will need to refer to a paper/hard copy manual, as they are not in electronic format on ISIS®. However, the electronic versions, found on ISIS®, of the Engine Diagnostic manuals, and Electronic Control System Diagnostic forms will also provide you with circuit diagrams.



CIRCUIT DIAGRAMS

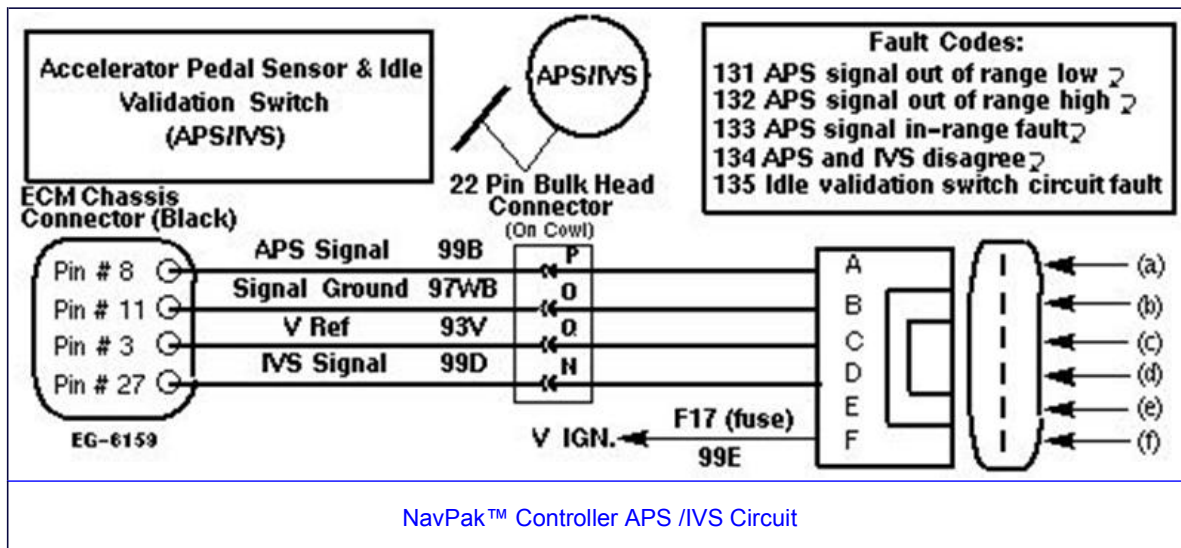

Connector Voltage Checks

(Check with Sensor Connector disconnected, and Ignition Key On)

Test Points	Specification	Comments
A to GND	< 0.25V	If greater than 0.25V, signal is shorted to V _{REF} or B+.
B to GND	0V	Signal ground no voltage expected.
C to GND	5 ± 0.5V	Voltage > spec, wire shorted to B+
D to GND	< 0.25V	Voltage > 0.25V, IVS signal wire shorted to V _{REF} or B+
F to GND	12V ± 1.5V	Voltage < 10.5V check circuit for open or resistance.

Harness Resistance Checks

(Check with breakout box installed on Chassis Harness and ZTSE-4485 - APS/ IVS Break Out Tee Connected to Chassis Harness Only)

Test Points	Specification	Comments
#8 to A	< 5 ohms	Resistance from 60 pin connector to harness connector - APS signal.
#11 to B	< 5 ohms	Resistance from 60 pin connector to harness connector - Signal ground.
#3 to C	< 5 ohms	Resistance from 60 pin connector to harness connector - V _{REF} .
#27 to D	< 5 ohms	Resistance from 60 pin connector to harness connector - IVS signal.
F17 to F	< 5 ohms	Resistance from V _{IGN.} power to harness connector.

Operational Voltage Checks

(Check with ZTSE-4485 - APS/ IVS Break Out Tee installed and APS/IVS sensor connected)

Position	APS Test Points (+) #8 to (-) #11		IVS Test Points (+) #27 to (-) #11		Operational Signal Checks (Check with breakout box installed on ECM and Engine Harness)
	Voltage	% APS	Voltage	% APS	Comments
Low Idle	0.64 - 0.66V	0 %	0 V	0 %	IVS toggles just off idle.
High Idle	3.84 - 3.86 V	98 - 102%	12 ± 1.5 V	98 - 102%	

NOTE:

If any of the circuit readings are not within the required specifications, keep in mind, that the IAT (Intake Air Temp.) sensor, is spliced with the signal ground and BAP (Barometric Air Press.) sensor circuits are spliced with the 5 volt reference circuits, of the APS/IVS. These circuits should also be inspected, as they can affect the APS/IVS function/readings.

NOTE:

When performing diagnostic tests, be sure to refer to the correct circuit diagram manuals for the vehicle you are working on.

If all circuit and operational tests have been performed, and all wiring/components have been inspected and are deemed to be satisfactory, yet the issue is still not resolved, open a tech service case file for further diagnostic assistance.

ADDITIONAL RELATED IKNOW DOCUMENTS:

- ik0800218 3-Box equipped vehicles
- ik0800223 DLCII equipped vehicles
- ik0800226 MaxxFORCE® equipped vehicles
- ik0800227 MaxxFORCE® 11 and 13 equipped vehicles

 Hide Details

Feedback Information

Viewed: 7478
 Helpful: 154
 Not Helpful: 137

No Feedback Found