

Technical Service Bulletin



48 Electric steering column adjustment is inoperative

48 14 62 2017266/8 September 23, 2014. Supersedes Technical Service Bulletin Group 48 number 14-59 dated June 2, 2014 for reasons listed below.

Model(s)	Year	VIN Range	Vehicle-Specific Equipment
A6	2005 - 2011	All	Not Applicable
A8	2003 - 2010	All	Not Applicable
Q7	2007 - 2013	All	Not Applicable
Q7	2014	000001 - 002000	Not Applicable

Condition

REVISION HISTORY		
Revision	Date	Purpose
8	-	Revised <i>Warranty</i> (Clarified wording of labor operations)
7	6/2/2014	Revised header data (Added VIN break) Revised <i>Production Solution</i> (Added solution) Revised <i>Service</i> (Removed steps) Revised <i>Warranty</i> (Updated TUs)
6	8/30/2013	Revised header data (Updated customer codes, workshop codes, and applicable model years) Revised <i>Condition</i> (Updated TSB in reference) Revised <i>Warranty</i> (Reformatted table)
5	8/13/2010	Revised header data (Controlling TSB display in ElsaWeb)
4	2/18/2009	Revise <i>Warranty</i>
3	11/4/2008	Revise Title to include Repair Group

- Electrically-adjustable steering column adjustment is restricted and does not adjust vertically.
- Incorrect operation of Easy Entry is not the cause. It is unlikely that external forces have led to the loss of the stored end positions of the adjustment movement. See TSB 2015819, *48 Easy Entry function of the power adjustable steering column intermittently does not work*, for more information.
- Seat adjustments can be used to maintain the 10-inch minimum recommended distance from the steering wheel in case of airbag deployment. The axial adjustment is still functional during this condition.

Technical Service Bulletin

Technical Background

The steering column may be under tension due to unfavorable tolerances of the steering column and module cross carrier. As a result, the current draw of the regulator motors is above specification, which causes the electric steering column adjustment to fail. Once the vehicle electrical system control module, J519 (address word 09), detects an excessive current draw, the basic settings will be erased. If basic settings are not stored in the vehicle electrical system control module, the module will not send voltage/current to the motor to operate the vertical adjustment.

Production Solution

Modified module cross carrier.

Service

Checking the electrically-adjustable steering column

1. Remove the steering column trim to gain access to the 8-pin (black) connector located under the dash.
2. Identify wires on T8d/1 and T8d/5. Install the current pick-up clamp around these wires (Figure 1).



Note:

Current will only flow on one wire at a time (up/down), so the current clamp can be placed over both wires. Current will only flow after basic settings have been set in the central electrics control module, J519.

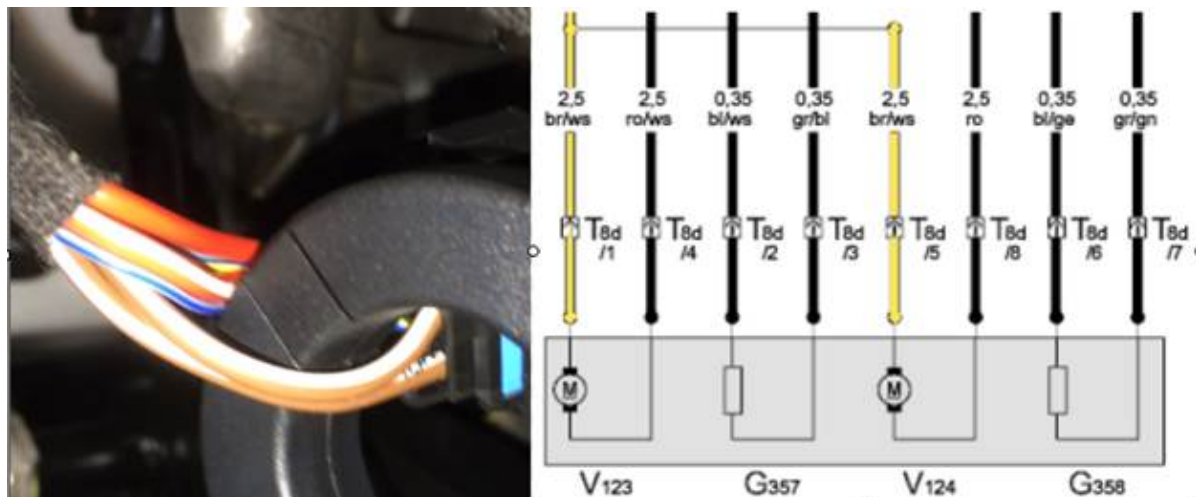

Figure 1. Current clamp installed (left), pins 1 and 5 (right).

3. Perform basic settings of the steering column in the J519 control module. Record the peak current values during the length and height adjustment.
 - The expected current draw in correct steering columns is about 1A for axial adjustments and about 2.8A - 3.4A for vertical adjustment (lower current draw typically found during testing, 2.0A-2.5A). Current draws

above these values are an indication of binding or a tight steering column.

4. Loosen the steering column from the cross carrier, then tighten the column according to ELSA instructions (Figure 2). This should relieve any tension between the steering column and cross carrier, if any existed.

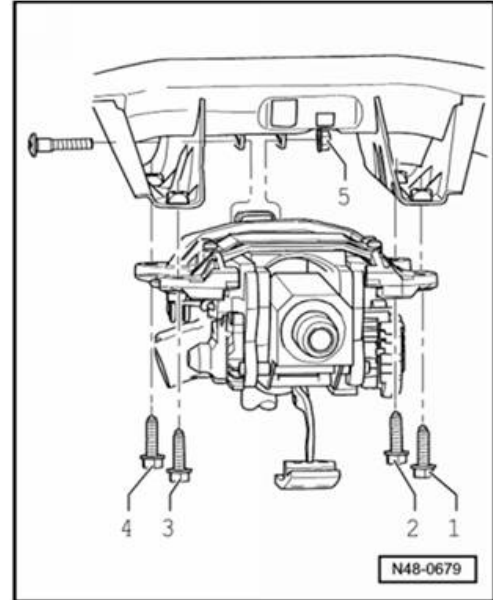



Figure 2. Tightening sequence (see ELSA for correct torque specifications)

5. Operate the steering column up and down and note the peak current draw:
 - If the current draw is lower and within the specifications after the mounting bolts have been loosened and retightened, the steering column had tension. If the current draw stays low after the reinstallation, the tension is only caused by the installation. An adjustment of the steering column is not necessary.
 - If the current draw rises to its original level after the reinstallation, the tension is caused by unfavorable tolerances of the components. The steering column must be adjusted as described in the instructions that follow.

Adjustment of the steering column to reduce belt tension

 **Tip:** Changing the tension of the belt drive may lead to an increased noise level during adjustment of the steering column.

1. Loosen the belt cover of the steering column:
 - If necessary, remove the footwell and steering column covers.
 - Next, move the height adjustment of the steering column to a central position.
 - Then, carefully loosen the side clips without damaging the clasps (Figure 3).

 **Note:**

Do not disconnect the wiring harness at the side on the cover attachment.

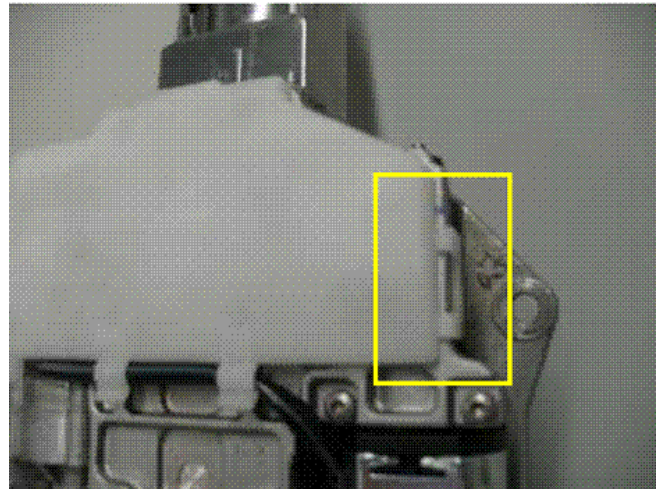

Figure 3. Side clips.

2. Carefully remove the gear belt from one gear wheel, using a fine screwdriver (Figure 4). Leave the gear belt removed from one wheel for step 3.



Figure 4. Remove the gear belt with a fine screwdriver.

3. Reduce the tension in the steering column:

- Mark the gear's original location on the gear, on the housing, and on the belt (Figure 5).



Figure 5. Marking original gear location.

- Turn the gear clockwise and mark the location with the greatest resistance (Figure 6).



Figure 6. Marking the location with the greatest resistance in the clockwise direction.

- Turn the gear counter-clockwise and mark the location with the greatest resistance (Figure 7).



Figure 7. Marking the location with the greatest resistance in the counter-clockwise direction.

- Place the original marking of the gear in the center of the two greatest resistance markings (Figure 8).



Figure 8. Placing a green dot in between the two yellow dots and turning the gear (red dot) to match the green dot on the housing.

4. Place the gear belt, by hand, on the gear wheel (Figure 9).

 **Note:**

The gear may have to move slightly to engage the belt during installation but other than that, the gear and green dot should line up (+/- ½ tooth). This will ensure that the gear is now centered between the two greatest resistance points.



Figure 9. Installation of gear belt.

5. Carefully reinstall the cover on the housing (Figure 10).

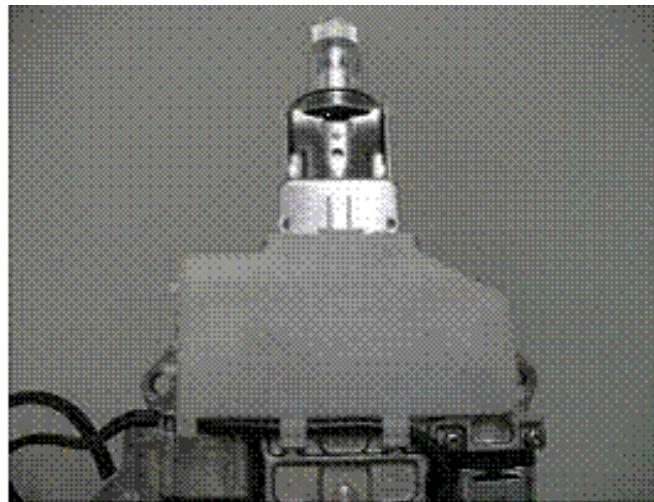

Figure 10. The cover, installed on the housing.

6. Perform the basic settings:
 - First, re-program the steering column with V.A.G. scan tool in the basic settings for the electronic central electrics module, J519.
 - Next, verify that the changing current values during length and height adjustment are no greater than specification (2.8A - 3.4A).
 - Perform a function check.
7. Reassemble the steering column.
8. Verify the proper function of the adjustment.
9. If concern is still present or there is excessive noise in the column, the column may need to be replaced. Please continue diagnosis of the steering column and follow ELSA instructions for further diagnostic steps and claiming information.

Technical Service Bulletin



Warranty

Claim Type:	Use applicable claim type. If vehicle is outside any warranty, this Technical Service Bulletin is informational only.		
Service Number:	4823		
Damage Code:	0017		
Labor Operations:	Checking the electrically-adjustable steering column	4823 0599	70 TU (Max)
	Adjustment of the steering column to reduce belt tension (if necessary)	4823 1599	30 TU (Max)
Diagnostic Time:	Road test prior to service procedure	No allowance	0 TU
	Road test after service procedure	No allowance	0 TU
	Technical diagnosis at dealer's discretion (Refer to Section 2.2.1.2 and Audi Warranty Online for DADP allowance details)		
Claim Comment:	As per TSB #2017266/8		
All warranty claims submitted for payment must be in accordance with the <i>Audi Warranty Policies and Procedures Manual</i> . Claims are subject to review or audit by Audi Warranty.			

Required Parts and Tools

Tool Description	Quantity
Electric current pick-up clamp	1
Fine screwdriver	1

Additional Information

All parts and service references provided in this TSB (2017266) are subject to change and/or removal. Always check with your Parts Department and service manuals for the latest information.