



Recall Bulletin



SERVICE PARTS SAFETY RECALL

SUBJECT: Ignition Switch Replacement

MODELS: 2008-2010 Chevrolet Cobalt
2008-2011 Chevrolet HHR
2008-2010 Pontiac Solstice
2008-2010 Pontiac G5
2008-2010 Saturn Sky

Customer notification letters for this recall were mailed beginning on April 24, 2014. The notification letter explains what the recall is about and what a customer should do until their vehicle is repaired. The letter also informs customers that when sufficient parts are available they will receive a second letter advising them to contact their dealer to arrange a service appointment for this repair.

Vehicles involved in this recall are also involved in recall 14113 or 14133. Check the Investigate Vehicle History (IVH) screen in the GM Global Warranty Management (GWM) system to determine which additional recall is applicable.

Please place orders only for ignition switch part number 23228993 and include the VIN. GMCCA will fulfill the order with the parts needed for both recalls based on this.

In the interest of customer satisfaction and to assist with dealer throughput, recall repairs for 14092 and 14113 or 14133 should be performed in a single dealer visit.

CONDITION

General Motors has decided that a defect which relates to motor vehicle safety exists in the following GM Parts and ACDelco Ignition & Start Switch service part number 10392423, and the following Ignition & Start Switch Housing Kits that contain or may contain part number 10392423: GM Parts and ACDelco service part numbers 10392737, 15857948, 15854953, 15896640, and 25846762. GM records indicate these service parts may have been installed during repairs in some 2008-2010 MY Chevrolet Cobalt, 2008-2011 MY Chevrolet HHR, 2008-2010 MY Pontiac Solstice, 2008-2010 MY Pontiac G5, and 2008-2010 MY Saturn Sky vehicles, as well as in some other GM vehicles.

The ignition switch torque performance on vehicles repaired with GM Parts and ACDelco Ignition & Start Switch part number 10392423 or assemblies that contain part number 10392423 may not meet General Motors' specification. If the torque performance is not to specification, the ignition switch may unintentionally move from the "run" position to the

“accessory” or “off” position with a corresponding reduction or loss of power. This risk may be increased if the key ring is carrying added weight or the vehicle goes off road or experiences some other jarring event. The timing of the key movement out of the “run” position, relative to the activation of the sensing algorithm of the crash event, may result in the airbags not deploying, increasing the potential for occupant injury in certain kinds of crashes.

Whenever a customer contacts you about the recalls it is imperative that you remind them of the following:

Until the recall repairs have been performed, it is very important before exiting the vehicle to make sure the vehicle is in “Park,” or in the case of a manual transmission, to put the transmission into reverse gear and set the parking brake. Also, customers should remove all items from their key ring, leaving only the vehicle key. The key fob (if applicable), should also be removed from the key ring.

CORRECTION

Dealers are to replace the ignition switch. (This is in addition to replacing the ignition cylinder (if necessary) and cutting and relearning new keys for safety recall 14113 or 14133, as appropriate, (to be performed during the same repair visit as 14092).)

VEHICLES INVOLVED

All involved vehicles are identified by Vehicle Identification Number on the Investigate Vehicle History screen in GM Global Warranty Management system. Dealership service personnel should always check this site to confirm vehicle involvement prior to beginning any required inspections and/or repairs. It is important to routinely use this tool to verify eligibility because not all similar vehicles may be involved regardless of description or option content.

For dealers with involved vehicles, a listing with involved vehicles containing the complete vehicle identification number, customer name, and address information has been prepared and will be provided to US and Canadian dealers through the GM GlobalConnect Recall Reports or sent directly to export dealers. Dealers will not have a report available if they have no involved vehicles currently assigned.

The listing may contain customer names and addresses obtained from Motor Vehicle Registration Records. The use of such motor vehicle registration data for any purpose other than follow-up necessary to complete this recall is a violation of law in several states/provinces/countries. Accordingly, you are urged to limit the use of this report to the follow-up necessary to complete this recall.

PART INFORMATION

Important: Due to a different vehicle security system, the ignition switch required for this recall is different than the ignition switch required for the 2003-2007 model year vehicles involved in recalls 13454 and 14063. We are diligently working with the supplier to obtain an initial supply of this new part (part number 23228993) as quickly as possible. Dealers will be notified when sufficient parts are available to begin repairing the 2008-2011 model year vehicles.

The parts required to complete this recall are to be obtained from General Motors Customer Care and Aftersales (GMCCA). Please refer to your “involved vehicles listing” before ordering.

Part Number	Description	Quantity/Vehicle
23228993	Ignition and Start Switch	1

Note: GMCCA will utilize the VIN number provided on the ignition switch order to place an order on your behalf for the parts required for this recall as well as to complete safety recall 14113 or 14133, whichever is applicable. This will ensure alignment of the ignition switch shipment with the parts needed to complete all required recalls. You will receive the parts required for the repair as kit number 23237271 (Chevrolet branded keys with cylinder) or kit number 23237272 (unbranded keys with cylinder) or 23237273 (Chevrolet branded keys without cylinder) or 23237274 (unbranded keys without cylinder). Each kit will also contain an ignition switch and two key rings.

Please refer to Global Connect message G_0000189595 for revised ignition switch parts ordering process instructions.

SERVICE PROCEDURE

CAUTION: To avoid part damage carefully read and follow the instructions below.

- Refer to the appropriate model and model year service procedure in Service Information (SI) BEFORE removing or replacing an ignition switch or key lock cylinder.
- If replacing both the ignition lock cylinder and the ignition and start switch, always replace the ignition and start switch first before removing the ignition lock cylinder, as misalignment between the ignition and start switch housing and the ignition and start switch will occur, resulting in permanent damage to the ignition and start switch.
- In order to allow the ignition and start switch to be removed or installed, always ensure the ignition lock cylinder is in the RUN position. Once the ignition and start switch is removed, do not move or turn the ignition lock cylinder during the procedure, as misalignment between the ignition and start switch housing and the ignition and start switch will occur, resulting in permanent damage to the ignition and start switch.
- Never rotate the actuator shaft on the ignition and start switch as permanent damage to the ignition and start switch will occur.
- When installing the ignition and start switch, if the switch does not freely slide into position, slightly rotate the ignition key clockwise and then counterclockwise while very lightly pressing on the ignition and start switch until it is fully seated.
- If a key learn procedure or programming event is required, use a Tech 2 or Tech 2 WIN scan tool.

Note: Vehicles involved in this safety recall are also involved in safety recall 14113 or 14133. Check the Investigate Vehicle History (IVH) screen in the GM Global Warranty Management (GWM) system to determine which additional field action is applicable. Perform the service procedure provided in that bulletin in conjunction with the repair described in this bulletin.

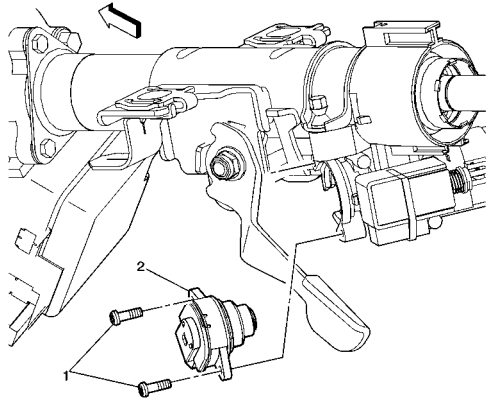

2085987

1. Remove the ignition switch from the vehicle. Refer to *Ignition and Start Switch Replacement* in SI.
2. Install a new ignition switch. Refer to *Ignition and Start Switch Replacement* in SI.

CUSTOMER REIMBURSEMENT – US

Customer requests for reimbursement of previously paid repairs for the recall condition are to be submitted to the dealer by May 31, 2015, unless otherwise specified by state law. If this is not convenient for the customer, they may mail the completed Customer Reimbursement Request Form and all required documents to the GM Customer Assistance Center.

All reasonable and customary costs to correct the condition described in this bulletin should be considered for reimbursement. Any questions or concerns should be reviewed with your GM representative prior to processing the request.

When a customer requests reimbursement, they must provide the following:

- A completed Customer Reimbursement Request Form. This form is mailed to the customer or can be obtained through GM GlobalConnect.
- The name and address of the person who paid for the repair.
- Paid receipt confirming the amount of the repair expense, a description of the repair, and the person or entity performing the repair.

IMPORTANT: GM requires dealers to approve or deny a reimbursement request within 30 days of receipt. If a reimbursement request is approved, the dealer should immediately issue a check to the customer and submit an appropriate warranty transaction for the incurred expense. If a reimbursement request is denied, the dealer MUST provide the customer with a clear and concise explanation, in writing, as to why the request was denied. The bottom portion of the Customer Reimbursement Request Form may be used for this purpose. If the denial was due to missing documents, the customer can resubmit the request when the missing documents are obtained, as long as it is still within the allowed reimbursement period.

Warranty transactions for customer reimbursement of previously paid repairs are to be submitted as required by GM Global Warranty Management. Additional information can also be found in Warranty Administration Bulletin 11-00-89-004.

CUSTOMER REIMBURSEMENT - For Canada and Export

Customer requests for reimbursement of previously paid repairs to correct the condition described in this bulletin are to be submitted to the dealer prior to or by May 31, 2015.

When a customer requests reimbursement, they must provide the following:

- Proof of ownership at time of repair.
- Original paid receipt confirming the amount of unreimbursed repair expense(s) (including Service Contract deductibles), a description of the repair, and the person or entity performing the repair.

All reasonable and customary costs to correct the condition described in this bulletin should be considered for reimbursement. Any questions or concerns should be reviewed with your GM representative prior to processing the request.

COURTESY TRANSPORTATION AND VEHICLE TOWING – For US and Canada

Please refer to Global Connect message G_0000187705 for courtesy transportation instructions.

For purposes of this recall, it is permissible to offer courtesy transportation to those customers who express concern about the continued use of their vehicle or who require alternate transportation while the vehicle is in for the recall repairs. The availability of courtesy transportation to such customers is very important in maintaining customer satisfaction. Dealers are to ensure that these customers understand that shuttle service or some other form of courtesy transportation is available and will be provided at no charge. Dealers should refer to the General Motors Service Policies and Procedures Manual for Courtesy Transportation guidelines. In addition, for purposes of this recall, it is permissible to provide free towing to a customer who may be concerned about operating their vehicle.

WARRANTY TRANSACTION INFORMATION

Submit a transaction using the table below. All transactions should be submitted as a ZFAT transaction type, unless noted otherwise.

Labor Code	Description	Labor Time	Net Item
9100466	Replace Ignition & Start Switch - Cobalt - HHR - Solstice - Sky	0.4 0.4 0.7 0.7	N/A
9100467*	Courtesy Transportation	N/A	***
9100468**	Customer Reimbursement Approved	0.2	****
9100469**	Customer Reimbursement Denied - For US Dealers Only	0.1	N/A

* To avoid having to “H” route this transaction for approval, it must be submitted prior to the repair transaction (U.S. only).

** To avoid having to “H” route this transaction for approval, it must be submitted prior to the repair transaction (U.S. and Canada). Note that customer reimbursement will not close this recall.

*** The amount identified in “Net Item” should represent the actual dollar amount for courtesy transportation.

*** The amount identified in "Net Item" should represent the actual dollar amount reimbursed to the customer.

CUSTOMER NOTIFICATION – For US and Canada

General Motors sent the attached letter to customers beginning April 24, 2014, to notify them of this recall on their vehicle.

CUSTOMER NOTIFICATION – For Export

Letters will be sent to known owners of record located within areas covered by the US National Traffic and Motor Vehicle Safety Act. For owners outside these areas, dealers should notify customers using the attached sample letter.

DEALER RECALL RESPONSIBILITY – For US and Export (US States, Territories, and Possessions)

It is a violation of Federal law for a dealer to deliver a new motor vehicle or any new or used item of motor vehicle equipment (including a tire) covered by this notification under a sale or lease until the defect or noncompliance is remedied.

The US National Traffic and Motor Vehicle Safety Act provides that each vehicle that is subject to a recall of this type must be adequately repaired within a reasonable time after the customer has tendered it for repair. A failure to repair within sixty days after tender of a vehicle is prima facie evidence of failure to repair within a reasonable time. If the condition is not adequately repaired within a reasonable time, the customer may be entitled to an identical or reasonably equivalent vehicle at no charge or to a refund of the purchase price less a reasonable allowance for depreciation. To avoid having to provide these burdensome remedies, every effort must be made to promptly schedule an appointment with each customer and to repair their vehicle as soon as possible. In the recall notification letters, customers are told how to contact the US National Highway Traffic Safety Administration if the recall is not completed within a reasonable time.

DEALER RECALL RESPONSIBILITY – All

All unsold new vehicles in dealers' possession and subject to this recall must be held and inspected/repaired per the service procedure of this recall bulletin before customers take possession of these vehicles.

Dealers are to service all vehicles subject to this recall at no charge to customers, regardless of mileage, age of vehicle, or ownership, from this time forward.

Customers who have recently purchased vehicles sold from your vehicle inventory, and for which there is no customer information indicated on the dealer listing, are to be contacted by the dealer. Arrangements are to be made to make the required correction according to the instructions contained in this bulletin. A copy of the customer letter is provided in this bulletin for your use in contacting customers. Recall follow-up cards should not be used for this purpose, since the customer may not as yet have received the notification letter.

In summary, whenever a vehicle subject to this recall enters your vehicle inventory, or is in your dealership for service in the future, you must take the steps necessary to be sure the recall correction has been made before selling or releasing the vehicle.



April 2014

Dear General Motors Customer:

This notice is sent to you in accordance with the National Traffic and Motor Vehicle Safety Act.

General Motors has decided that one or more defects as described below which relate to motor vehicle safety may exist in all 2008-2010 model year (MY) Chevrolet Cobalt, 2008-2011 MY Chevrolet HHR, 2008-2010 MY Pontiac Solstice, 2008-2010 MY Pontiac G5, and 2008-2010 MY Saturn Sky vehicles. As a result, GM is conducting a recall. We apologize for this inconvenience. However, we are concerned about your safety and continued satisfaction with our products.

IMPORTANT

- This notice applies to your 2008-2010 model year (MY) Chevrolet Cobalt, 2008-2011 MY Chevrolet HHR, 2008-2010 MY Pontiac Solstice, 2008-2010 MY Pontiac G5 or 2008-2010 MY Saturn Sky vehicle.

Until the recall repairs have been performed, it is very important that you remove all items from your key ring, leaving only the vehicle key. The key fob (if applicable), should also be removed from your key ring. Also, when exiting your vehicle, always make sure your vehicle is in “Park”, or in the case of a manual transmission, put the transmission into reverse gear and set the parking brake.

- Parts are not presently available to remedy your vehicle. When parts become available, GM will send you another letter to notify you to schedule an appointment with your GM dealer.
- The recall will be performed for you at **no charge**.

Why is your vehicle being recalled?

GM records indicate a defective Ignition & Start Switch or a kit containing a defective Ignition & Start Switch may have been installed in some 2008-2010 MY Chevrolet Cobalt, 2008-2011 MY Chevrolet HHR, 2008-2010 MY Pontiac Solstice, 2008-2010 MY Pontiac G5, and 2008-2010 MY Saturn Sky vehicles.

If your vehicle has the defective Ignition & Start Switch, there is a risk, under certain conditions, that your ignition switch may move out of the “run” position, resulting in a partial loss of electrical power and turning off the engine. This risk increases if your key ring is carrying added weight (such as more keys or the key fob) or your vehicle experiences rough road conditions or other jarring or impact related events. If the ignition switch is not in the run position, the air bags may not deploy if the vehicle is involved in a crash, increasing the risk of injury or fatality.

Some of these vehicles may also have a condition in which the ignition key may be removed when the ignition is not in the “Off” position. If the ignition key is removed when the ignition is not in the “Off” position, unintended vehicle motion may occur: (a) for an

automatic transmission, if the transmission is not in “Park”; or (b) for a manual transmission, if the parking brake is not engaged and the transmission is not in reverse gear. This could result in a vehicle crash and occupant or pedestrian injuries.

Until the recall repairs have been performed, it is very important that you remove all items from your key ring, leaving only the vehicle key. The key fob (if applicable), should also be removed from your key ring. Also, when exiting your vehicle, always make sure your vehicle is in “Park”, or in the case of a manual transmission, put the transmission into reverse gear and set the parking brake.

What will we do?

Whether or not your ignition switch has been previously serviced, GM will replace the ignition switch on your vehicle. This measure is being taken in an abundance of caution, to make sure all defective ignition switches have been removed from all vehicles.

PARTS ARE NOT CURRENTLY AVAILABLE, but when parts are available, your GM dealer will replace the ignition switch on your vehicle whether it is the original switch or a replacement, and for vehicles that have not previously had an ignition cylinder replacement under warranty, dealers will replace the ignition cylinder. Dealers will also cut and if necessary re-learn two ignition keys for each vehicle. This service will be performed for you at **no charge**. Because of scheduling requirements, it is likely that your dealer will need your vehicle longer than the actual service correction time of approximately 90 minutes.

We are working as quickly as possible to obtain parts. We will notify you with at least a second letter as soon as parts are available so that you can schedule an appointment with your dealer to have your vehicle repaired.

If required, your GM dealer will provide you with some form of courtesy transportation at no charge while your vehicle is at the dealership for this repair.

What should you do?

When GM notifies you that parts are available, you should contact your GM dealer to arrange a service appointment. **Until the recall repairs have been performed, it is very important that you remove all items from your key ring, leaving only the vehicle key. The key fob (if applicable), should also be removed from your key ring. Also, when exiting your vehicle, always make sure your vehicle is in “Park”, or in the case of a manual transmission, put the transmission into reverse gear and set the parking brake.**

Did you already pay for this repair? When GM notifies you that parts are available, GM will also provide instructions for you to request reimbursement if you paid for repairs for the recall condition previously.

Do you have questions? If you have questions or concerns that your dealer is unable to resolve, please contact the appropriate Customer Assistance Center at the number listed below.

Division	Number	Text Telephones (TTY)
Chevrolet	1-800-222-1020	1-800-833-2438
Pontiac	1-800-762-2737	1-800-833-7668
Saturn	1-800-553-6000	1-800-833-6000
Puerto Rico – English	1-800-496-9992	
Puerto Rico – Español	1-800-496-9993	
Virgin Islands	1-800-496-9994	

If after contacting your dealer and the Customer Assistance Center, you are still not satisfied we have done our best to remedy this condition without charge and within a reasonable time, you may wish to write the Administrator, National Highway Traffic Safety Administration, 1200 New Jersey Avenue, SE., Washington, DC 20590, or call the toll-free Vehicle Safety Hotline at 1.888.327.4236 (TTY 1.800.424.9153), or go to <http://www.safercar.gov>. The National Highway Traffic Safety Administration Campaign ID Number for these recalls are 14V047 and 14V171.

Federal regulation requires that any vehicle lessor receiving this recall notice must forward a copy of this notice to the lessee within ten days.

For additional information regarding this recall, please go to www.gmignitionupdate.com.

Jim Moloney
General Director,
Customer and Relationship Services

GM Recall Numbers: 14092 and 14113 or 14133