



# Recall Bulletin



## PRODUCT SAFETY RECALL

**SUBJECT:** Incorrect Drivers Outboard Front Seat Hook Bracket

**MODELS:** 2015 Cadillac SRX

It is a violation of Federal law for a dealer to deliver a new motor vehicle or any new or used item of motor vehicle equipment (including a tire) covered by this notification under a sale or lease until the defect or noncompliance is remedied.

Vehicles involved in this recall were placed on stop delivery December 17, 2015. Once the service procedure contained in this bulletin has been performed on the vehicle, the vehicle is released from stop delivery and the vehicle can be delivered to the customer.

All involved vehicles that are in dealer inventory must be held and not delivered to customers, dealer traded, or used for demonstration purposes until the repair contained in this bulletin has been performed on the vehicle.

### CONDITION

General Motors has decided that a defect which relates to motor vehicle safety exists in certain 2015 model year Cadillac SRX utility vehicles. In certain of these vehicles, the front driver-side seats may have been built with the incorrect seat track bracket. Driver seats with this condition may not be properly attached to the seat track, which could result in an audible buzz or rattle. In the event of a severe rear collision, a portion of the driver seat – i.e., the front outboard seat bracket – may disengage from the seat track, potentially increasing the risk of injury.

### CORRECTION

Dealers are to inspect, and if required replace the drivers outboard front seat hook bracket.

### VEHICLES INVOLVED

All involved vehicles are identified by Vehicle Identification Number on the Investigate Vehicle History screen in GM Global Warranty Management system. Dealership service personnel should always check this site to confirm vehicle involvement prior to beginning any required inspections and/or repairs. It is important to routinely use this tool to verify eligibility because not all similar vehicles may be involved regardless of description or option content.

For dealers with involved vehicles, a listing with involved vehicles containing the complete vehicle identification number, customer name, and address information has been prepared and will be provided to US and Canadian dealers through the GM GlobalConnect Recall Reports. Dealers will not have a report available if they have no involved vehicles currently assigned.

The listing may contain customer names and addresses obtained from Motor Vehicle Registration Records. The use of such motor vehicle registration data for any purpose other than follow-up necessary to complete this recall is a violation of law in several states/provinces/countries. Accordingly, you are urged to limit the use of this report to the follow-up necessary to complete this recall.

### PART INFORMATION

The driver outboard front seat hook bracket will be shipped from the Warranty Parts Center (WPC) at no charge via UPS 2-Day Delivery – Attention: Parts Manager, to dealers with involved vehicles beginning Wednesday, December 17, 2014. All dealers who have involved vehicles should have the driver outboard front seat hook bracket no later than Saturday, December 20, 2014. Drivers outboard front seat hook bracket needed for dealer-trades are to be obtained by calling the WPC at 248-371-9900, and requesting WPC#779.

| Part Number | Description                              | Quantity/Vehicle |
|-------------|--|------------------|
| WPC779      | Drivers Outboard Front Seat Hook Bracket | 1 (If Required)  |

### INSPECTION PROCEDURE

1. Adjust the driver seat to the full upward, full rearward position.



4051021

2. Carefully remove the driver front outboard seat track cover (1). Refer to *Front Seat Adjuster Track Finish Cover Replacement (Front)* in SI.

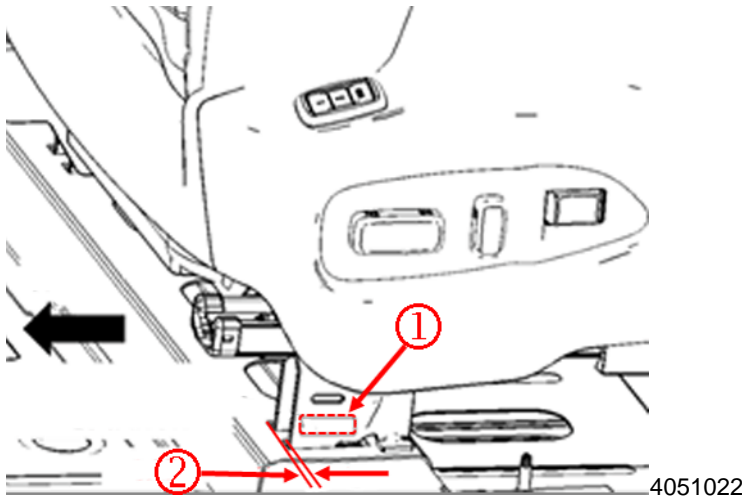

3. Inspect the driver front outboard seat hook bracket for a part number identification stamping (1) AND for the proper gap between the bracket and the slot in the floor sheet metal (2).

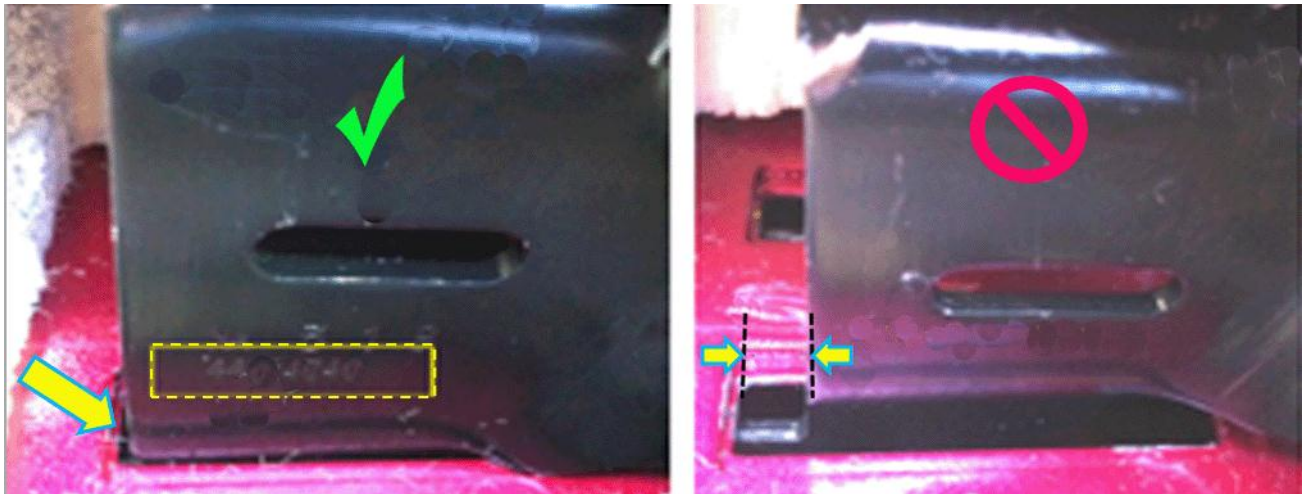

4051023

- Correct parts can be identified one or two ways: 1) a very small gap of 0 - 3mm (0.118 in) (in photo at left) should exist between the hook bracket and the forward edge of the floor slot or 2) a part number identification stamp (P/N 44816740 in the dashed box above) should be visible below the A-Clip attachment hole. If either of these conditions exist, the seat track cover can be reinstalled and no further action is required.
- If the hook bracket has a large gap of 7mm (0.275 in) (as shown above on the right) or greater and/or DOES NOT have the part number identification stamp, the bracket will need replacement. Proceed to **Seat Bracket Service Procedure below**.

### Seat Bracket Replacement Procedure

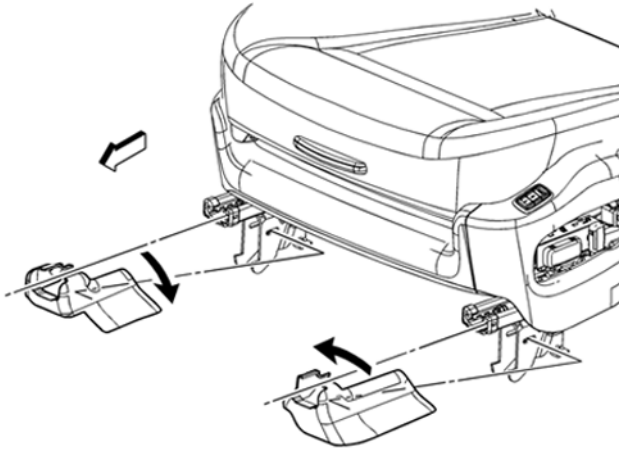

4051024

1. Remove the inboard driver front seat track cover.
2. Adjust the driver front seat into the full forward position to gain access to the rear attachment bolts.

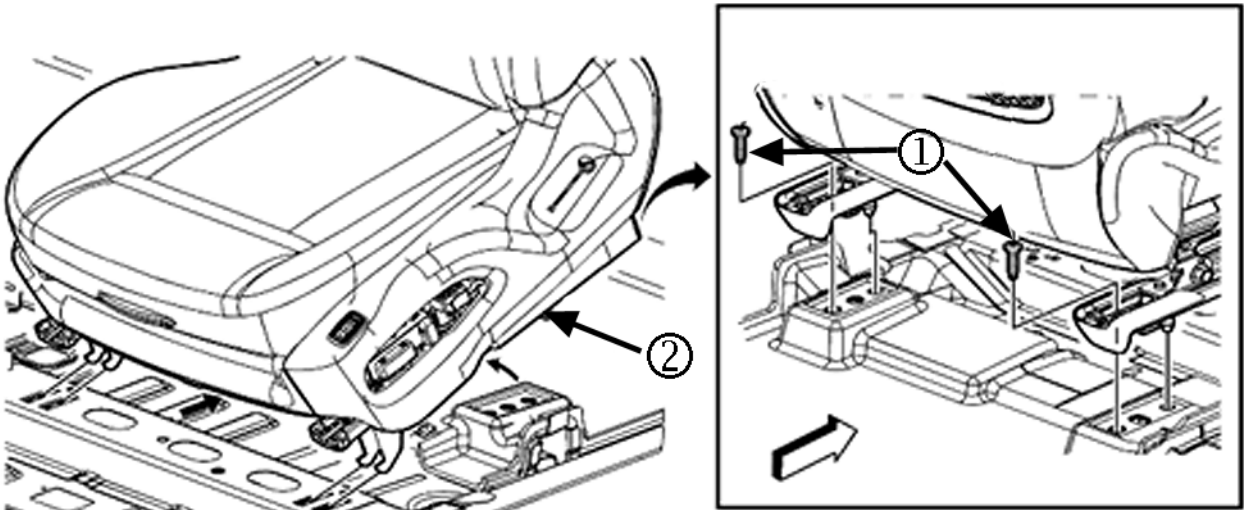

4051025

**Note:** It is not necessary to remove the seat assembly from the vehicle

3. Remove the rear seat track bolts (1), tilt the seat (2) forward, and then lift/pull rearward to disengage the front track hooks.
4. Position the seat laying rearward to access the underside seat track.

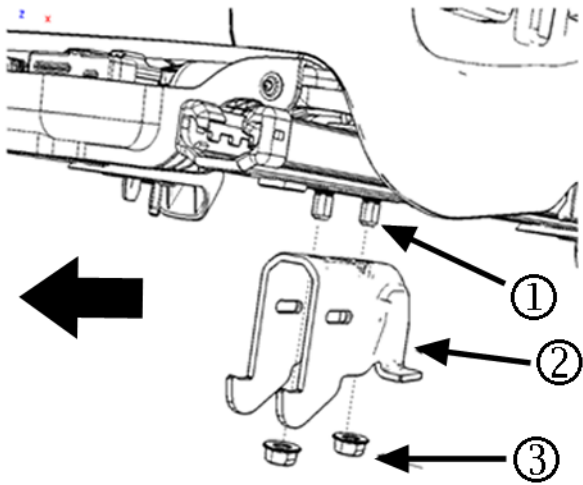

5. Remove the two nuts (3) retaining the driver front seat outer hook bracket to the track rail. Remove and discard the original hook bracket (2).
6. Apply medium strength blue thread locker P/N 12345382, or equivalent, to the seat track studs (1).
7. Install the new replacement bracket (2) to the rail with the hooks oriented forward and install the original nuts (3). Tighten the nuts to 24 N\*m (17.5 lb ft).

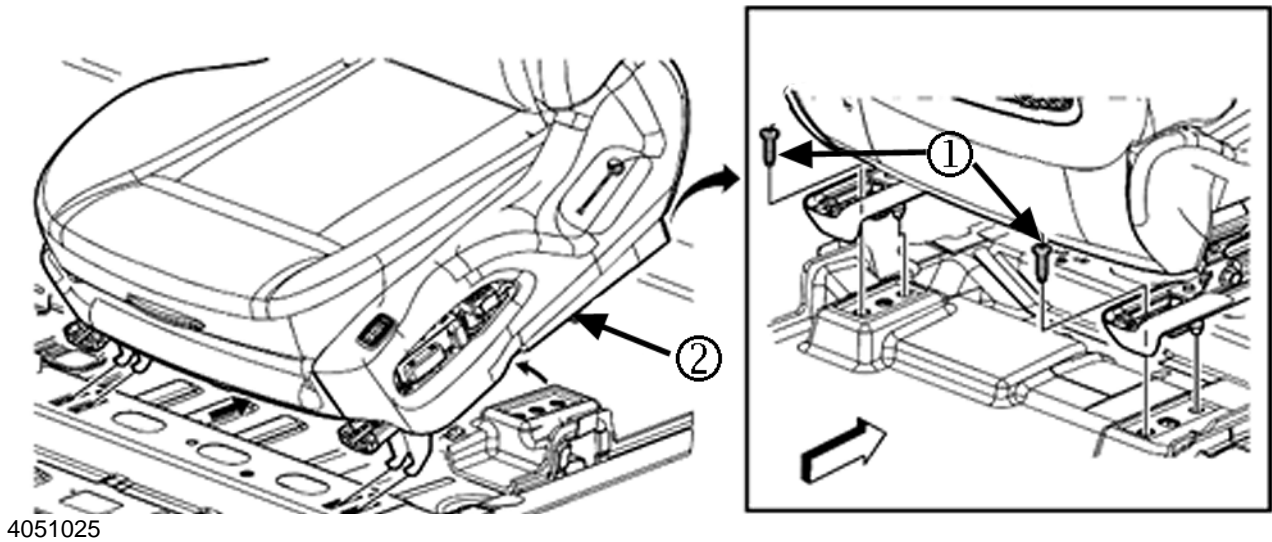

8. Reinstall the seat to the vehicle, and secure the rear bolts (1) to 45N\*m (33 lb ft).

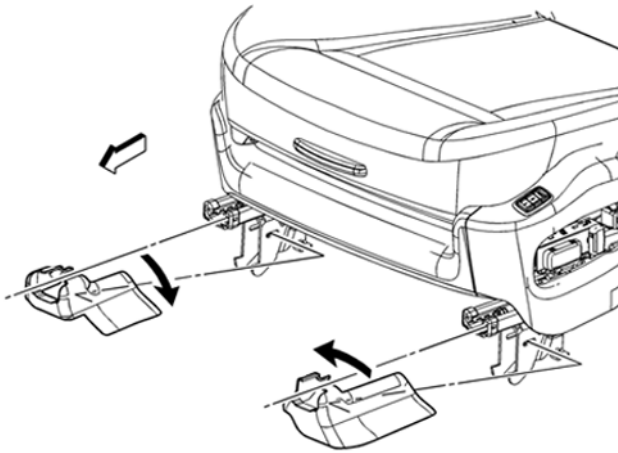

4051024

To Re-install the inboard and outboard front seat track covers. Refer to *Front Seat Adjuster Track Finish Cover Replacement (Front)* in SI.

**COURTESY TRANSPORTATION** – For US and Canada

The General Motors Courtesy Transportation program is intended to minimize customer inconvenience when a vehicle requires a repair that is covered by the New Vehicle Limited Warranties. The availability of courtesy transportation to customers whose vehicles are within the warranty coverage period and involved in a product program is very important in maintaining customer satisfaction. Dealers are to ensure that these customers understand that shuttle service or some other form of courtesy transportation is available and will be provided at no charge. Dealers should refer to the General Motors Service Policies and Procedures Manual for Courtesy Transportation guidelines.

**WARRANTY TRANSACTION INFORMATION**

Submit a transaction using the table below. All transactions should be submitted as a ZFAT transaction type, unless noted otherwise.

| Labor Code | Description  | Labor Time | Net Item |
|------------|--|------------|----------|
| 9101159    | Inspect Driver Seat Front Outboard Hook Bracket                    | 0.2        | N/A      |
| 9101169    | Replace Driver Seat Front Outboard Hook Bracket (Incl. Inspection) | 0.5        | *        |

\*Dealers who performed repairs with a part shipped to their dealership from the WPC, are to submit for the applicable Mark-Up or Landed Cost (for Export) in Net Item field. The amount identified in “Net Item” should represent the actual sum total not to exceed \$6.40USD, \$7.50 CAD.

**CUSTOMER NOTIFICATION** – For US and Canada

General Motors will notify customers of this recall on their vehicle.

## DEALER RECALL RESPONSIBILITY – For US and Export (US States, Territories, and Possessions)

It is a violation of Federal law for a dealer to deliver a new motor vehicle or any new or used item of motor vehicle equipment (including a tire) covered by this notification under a sale or lease until the defect or noncompliance is remedied.

The US National Traffic and Motor Vehicle Safety Act provides that each vehicle that is subject to a recall of this type must be adequately repaired within a reasonable time after the customer has tendered it for repair. A failure to repair within sixty days after tender of a vehicle is prima facie evidence of failure to repair within a reasonable time. If the condition is not adequately repaired within a reasonable time, the customer may be entitled to an identical or reasonably equivalent vehicle at no charge or to a refund of the purchase price less a reasonable allowance for depreciation. To avoid having to provide these burdensome remedies, every effort must be made to promptly schedule an appointment with each customer and to repair their vehicle as soon as possible. In the recall notification letters, customers are told how to contact the US National Highway Traffic Safety Administration if the recall is not completed within a reasonable time.

## DEALER RECALL RESPONSIBILITY – All

All unsold new vehicles in dealers' possession and subject to this recall must be held and inspected/repaired per the service procedure of this recall bulletin before customers take possession of these vehicles.

Dealers are to service all vehicles subject to this recall at no charge to customers, regardless of mileage, age of vehicle, or ownership, from this time forward.

Customers who have recently purchased vehicles sold from your vehicle inventory, and for which there is no customer information indicated on the dealer listing, are to be contacted by the dealer. Arrangements are to be made to make the required correction according to the instructions contained in this bulletin.

In summary, whenever a vehicle subject to this recall enters your vehicle inventory, or is in your dealership for service in the future, you must take the steps necessary to be sure the recall correction has been made before selling or releasing the vehicle.



**IMPORTANT NOTE WHEN PRINTING THIS FORM:** If the form prints out on two pages, make certain you fax both pages so the WPC receives the needed information. Missing information will delay or prevent the part from being shipped.

**Part Request Form — Warranty Parts Center**

Use this form **ONLY** for U.S. & Canada Dealers. Export markets & Mexico Dealers must contact their regional Technical Assistance Center for assistance.

**To:** Warranty Parts Center  
**Email:** [warrantypartscenterusa@gm.com](mailto:warrantypartscenterusa@gm.com)  
**or WPC Fax:** 248-371-0192  
**Attn:** Amina Winfrey

Part Being Requested: **Driver Outboard Front Seat Hook Bracket WPC #779**

Dealer BAC (U.S.) / Dealer Code (Canada):

Dealer Name:

Dealer Address:

Dealer Contact Person:

Dealer Phone Number:

Repair Order Number:

Vehicle VIN:

**IMPORTANT:** If you do not receive the part within 2 business days after emailing or faxing your part request to the Warranty Parts Center, please call Customer Assistance at 248-371-9901/9902.

**IMPORTANT NOTE WHEN PRINTING THIS FORM:** If the form prints out on two pages, make certain you fax both pages so the WPC receives the needed information. Missing information will delay or prevent the part from being shipped.