



Service Bulletin



SERVICE UPDATE

SUBJECT: Service Update for Inventory and Customer Vehicles
Door Striker Appearance
Expires with Base Warranty

MODELS: 2014 Chevrolet Cruze

This service update includes vehicles in dealer inventory and customer vehicles that return to the dealership for any reason. This bulletin will expire at the end of the involved vehicle's New Vehicle Limited Warranty period.

PURPOSE

This bulletin provides a service procedure to replace all door strikers on **certain** 2014 model year Chevrolet Cruze vehicles. The door strikers on these vehicles may have been incorrectly plated, giving the appearance of "pitting". There are no safety issues with the strikers; this is only an appearance issue.

This service procedure should be completed as soon as possible on involved vehicles currently in dealer inventory and customer vehicles that return to the dealer for any type of service during the New Vehicle Limited Warranty coverage period.

VEHICLES INVOLVED

All involved vehicles are identified by VIN in the Global Warranty Management System – Investigate Vehicle History Application. Dealership technicians should always check this site to confirm vehicle involvement prior to beginning any required inspections and/or repairs. It is important to routinely use this tool to verify eligibility because not all similar vehicles may be involved regardless of description or option content.

Additionally, a list of involved vehicles currently in dealer inventory is available on the "Service Update Bulletin Information" link under the "Service" tab in GM GlobalConnect (US) or attached to the GlobalConnect message (Canada) used to release this bulletin. Customer vehicles that return for service, for any reason, and are still covered under the vehicle's base warranty should also be checked for vehicle eligibility.

PART INFORMATION

Parts required to complete this service update are to be obtained from General Motors Customer Care and Aftersales (GMCC&A). Please refer to your “involved vehicles listing” before ordering parts. Normal orders should be placed on a DRO = Daily Replenishment Order. In an emergency situation, parts should be ordered on a CSO = Customer Special Order.

Part Number	Description	Quantity/Vehicle
13503000	Striker, Side Door Lock	0-4

SERVICE PROCEDURE

Use the following steps to inspect and replace the side door latch strikers. This condition may be present on all four door latch strikers on the vehicle. Only replace strikers that display the condition.



3975217

Correct Appearance



3975216

Example of Unacceptable Part

Note: the same part number services all four door locations.

For vehicles that have unacceptable parts, use the following steps to replace the side door latch striker(s).



3975215

1. Using a grease pencil, mark the location of the striker on the vehicle.

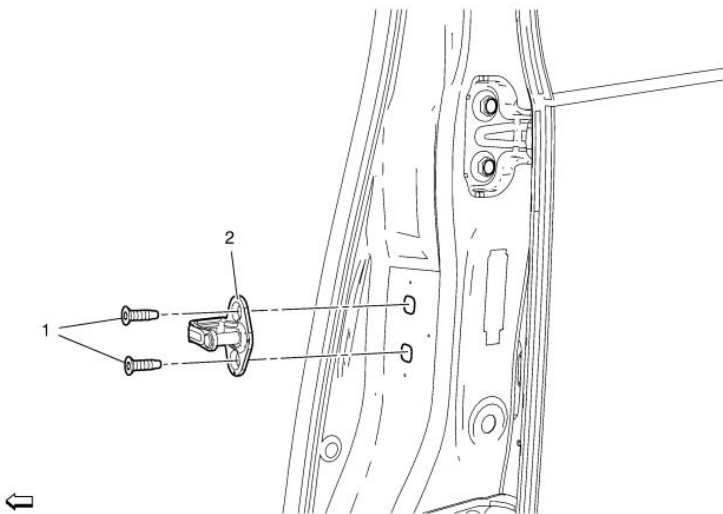

2371619

2. Remove the striker fasteners (1) and remove the striker (2) from the vehicle. Save the fasteners.
3. Note any shims or spacers placed between the striker and the body.
4. Install the new striker using the existing fasteners, do not tighten. Ensure any shims removed during removal are installed in the exact same location.
5. Using the grease pencil marks, locate the striker in the same position as the original.
Tighten: 25 N.m (18 lb ft).
6. Remove the grease pencil marks.

WARRANTY TRANSACTION INFORMATION

Submit a transaction using the table below. All transactions should be submitted as a ZFAT transaction type, unless noted otherwise.

Labor Code	Description	Labor Time
9100877	Inspect Door Latch Striker – No Further Action Req'd	0.2
9100878	Inspect & Replace 1 Side Door Striker	0.2
	Add : Replace Additional Striker (each)	0.1

DEALER PROGRAM RESPONSIBILITY

Whenever a vehicle subject to this service update enters your vehicle inventory, or is in your facility for service in the future, and the vehicle is still covered under the New Vehicle Limited Warranty, you must take the steps necessary to be sure the service update correction has been made before selling or releasing the vehicle.

