

Technical Service Bulletin



87D9 UPDATE – AC Pressure/Temperature Sensor (NVLW)

October 15, 2014

Model(s)	Year	VIN Range	Vehicle-Specific Equipment
R8 Coupe, R8 Spyder, A6, S6, A7, S7, A8, S8, A5 Cab, S5, Cab, RS5 Cab, A4 S4, allroad, Q5, Q5 hybrid, A5, S5, RS5	2013 - 2014	See Campaign/Action screen in Elsa	None

Condition

REVISION HISTORY		
Revision	Date	Purpose
1	April 03, 2014	- Original Publication
2	October 14, 2014	- Updated serial number format in Step 2. - Added note to record serial number on RO and Claim Comments.
3	October 15, 2014	- Updated wording to say production date instead of serial number to the revision statements from the 14 th .

This Update has been proactively released to prevent the following condition from occurring in the vehicle:

On Audi vehicles manufactured within a specific period, the refrigerant pressure sensor for the air conditioner may fail after a period of time. As a result, the air conditioner compressor is switched off.

This Update is in effect until removed.

Vehicle must meet all of the following criteria:

- Procedure is valid only for vehicles that show the **87D9** code in the Elsa Campaign/Action Information screen on the day of repair.
- Vehicle must be within the New Vehicle Limited Warranty.
- Procedure must be performed within the allotted time frame stated in this Technical Service Bulletin.
- Procedure must be performed on applicable vehicles in dealer inventory prior to sale.

Technical Background

On Audi vehicles manufactured within a specific period, the refrigerant pressure sensor for the air conditioner may fail after a period of time. As a result, the air conditioner compressor is switched off.

Service

1. Remove the refrigerant pressure sensor -G395- <A> by following the instruction in ElsaPro >> Repair Manual >> Heating, Ventilation and Air Conditioning >> 87 Air Conditioning >> Removal and Installation >> A/C Pressure/Temperature Sensor G395.

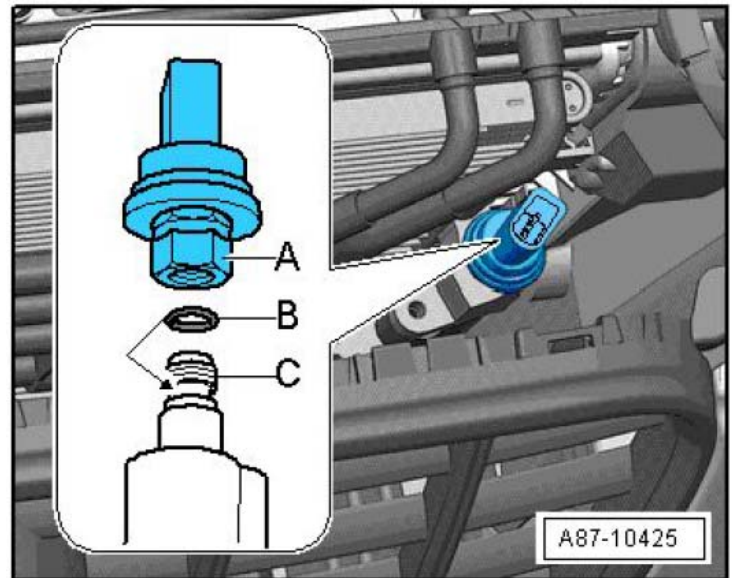

2. Check production date of sensor.

Example: 3 13612

3: Shift
1: Day
36: Week
12: Year (2012)

- Replace sensor **ONLY** if the last 4 or 5 numbers are:

- 3212
- 3312
- 3412
- 3512
- 3612
- 3712
- 3812
- 3912
- 54612

- Record production date on repair order to be included on claim entry.

- If the sensor date is not within these ranges reinstall sensor with new o-ring, PN 7H0820896.



Technical Service Bulletin



Warranty

Update Time Requirements/ Reimbursement	To ensure prompt and proper payment, be sure to immediately enter the applicable reimbursement code listed below upon completion of the repair work. Claims will be paid only for vehicles that show the 87D9 code in the Elsa Campaign/Action Information screen on the day of repair.		
<p>87D9 Saga Claim Entry Procedure</p> <p>Check Elsa to determine whether Update 87D9 is open.</p> <p>Service No.: 87D9 Damage Code: 0099 Parts Manufacturer - Removed part: 002</p> <p>Claim Type</p> <p>Sold vehicle = 7 10 Unsold vehicle = 7 90</p> <p>Saga Accounting Instructions</p>			
Criteria ID	Repair operation	Labor Operation Number	TU
8K or 8T or 8R or 4G	Remove and install refrigerant pressure sender; check and replace if necessary	8709 1900	40
8F	Remove and install refrigerant pressure sender; check and replace if necessary	8757 1900	30
4H	Remove and install refrigerant pressure sender; check and replace if necessary	8709 1900	50
42	Remove and install bumper cover (front)	6329 1900	90
	Remove and install refrigerant pressure sender; check and replace if necessary	8709 1950	20
Criteria ID	Part Number	Part Description	Quantity
8K or 8T or 8R or 4G or 8F or 42	4H0959126A *	Pressure sensor	1.00
	7H0820896	O-ring	1.00
<p>* Include production date from the replaced sensor in the comments of the claim or the claim will not be paid.</p>			

Technical Service Bulletin



There is no reimbursement for vehicle wash or loaner vehicle.

If the vehicle is outside of the specified warranty period OR if customer refused repairs.

U.S. dealers: Submit the request through Audi Warranty Online under the Campaigns/Update option.

Canadian dealers: Fax the Repair Order to Warranty at (905) 428-4811 and provide VIN, applicable Service Number, Customer Information, Dealer Number and Date.

Additional Actions Some of the affected vehicles may be involved in additional Actions. Please check your Elsa Campaign/Action Information screen so that any *additional required work can be done simultaneously.*

Verifying Vehicle Eligibility To verify vehicle eligibility for this Update, *always* check the Elsa Campaign/Action Information screen. The Elsa system is the *only* binding inquiry and verification system; other systems are not valid and *may result in non-payment* of a claim.

Help for Claim Entry For questions regarding claim entry, contact Audi Warranty.

Required Customer Notification Inform your customer in writing by recording on the Repair Order any and all work that was conducted on the vehicle, including any and all updates completed under this Update.

Required Parts and Tools

Part Number	Part Description	Quantity
4H0959126A	Pressure sensor	1.00
7H0820896	O-ring	1.00

- Properly destroy and dispose of removed parts in accordance with all state and local requirements, unless otherwise indicated and/or requested through SAGA.
- If you have exhausted your allocated parts and you require additional parts for vehicles affected by this Update but have exceeded your Upper Order Limit, please submit your requests for additional parts via email to upperorderlimits@audi.com. Be sure to include the affected VINs with your order. Prior to submitting your request, ensure that each vehicle has the **87D9** code open in Elsa. Your order will be reviewed and processed accordingly.

Additional Information

All parts and service references provided in this Update are subject to change and/or removal. Always check Elsa for the most current version of this document.