



NUMBER: 09-001-14

GROUP: Engine

DATE: May 22, 2014

This bulletin is supplied as technical information only and is not an authorization for repair. No part of this publication may be reproduced, stored in a retrieval system, or transmitted, in any form or by any means, electronic, mechanical, photocopying, or otherwise, without written permission of Chrysler Group LLC.

SUBJECT:

Hard Contact Knocking Noise In Engine Compartment Primarily While Turning Left

OVERVIEW:

This bulletin involves replacing the rear engine mount bracket.

MODELS:

2011-2014 JC Journey

NOTE: This bulletin applies to vehicles built on or before March 23, 2014 (MDH0223XX) equipped with the 2.0L I4 Turbo Diesel Engine (Sales Codes EBT) and All Wheel Drive (AWD) (Sales Codes 590).

SYMPTOM/CONDITION:

Hard contact knocking noise in the engine compartment caused by contact between the Rear Engine Mount Bracket and the fastener on the Power Transfer Unit (PTU). Noise heard primarily while turning left.

DIAGNOSIS:

If the customer describes the symptom, perform the Repair Procedure.

PARTS REQUIRED:

Qty.	Part No.	Description
1	68111309AC	BRACKET, Engine Mount, Rear
1	52022294AA	GASKET, Crossunder Pipe, Exhaust

REPAIR PROCEDURE:

1. Raise and support the vehicle. Refer to the detailed repair procedures available in: DealerCONNECT> TechCONNECT under: Service Info> 04 - Vehicle Quick Reference> Hoisting - Standard Procedure.
2. Remove the belly pan (Fig. 1).

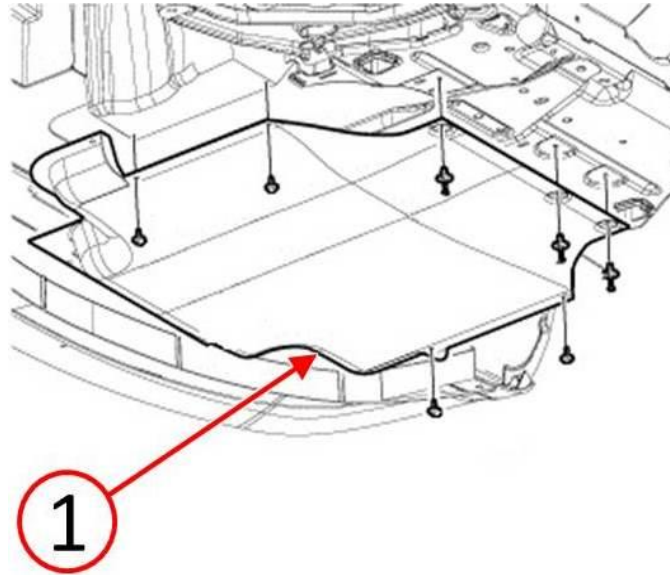

Fig. 1 Belly Pan Removal

1 - Belly Pan

3. Inspect for evidence of contact between the Rear Engine Mount Bracket (2) and the fastener (1) on the PTU (Fig. 2). Is evidence of contact observed?
 - a. YES, contact is observed.>>> Continue with [Step #4](#).
 - b. NO, contact is NOT observed.>>> Continue with further diagnosis. This bulletin does not apply.

NOTE: Engine mount insulator is removed in (Fig. 2) close up image for clarity.

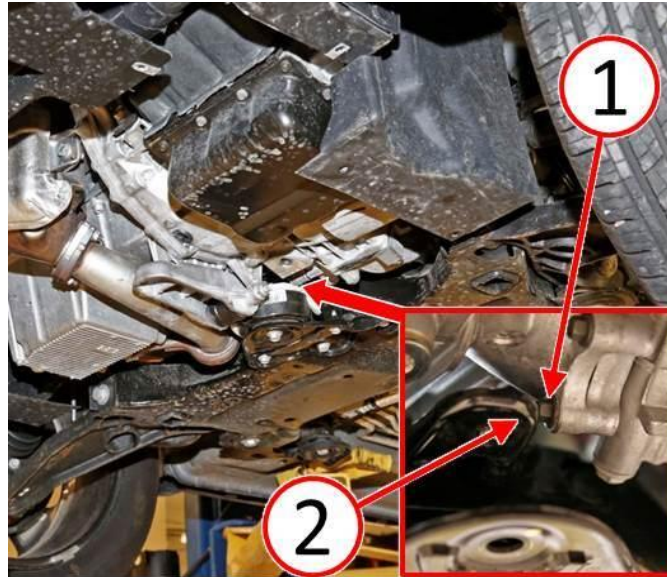

Fig. 2 Area Of Contact Concern

- 1 - PTU Fastener
- 2 - Rear Engine Mount Bracket

-
4. Replace the Rear Engine Mount Bracket. Refer to the detailed repair procedures available in: DealerCONNECT> TechCONNECT under: Service Info> 09 - Engine, 2.0L Diesel> Engine Mounting> BRACKET, Engine Mount, Rear Mount> Removal/Installation.

NOTE: The exhaust crossunder pipe gasket must be replaced as part of the Rear Engine Mount Bracket replacement procedure.

NOTE: When replacing the Rear Engine Mount Bracket (1), remove only the outer fasteners (2). It is not necessary to remove the center fasteners (4) securing the Upper Engine Mount Bracket (3) to the front suspension crossmember (Fig. 3).

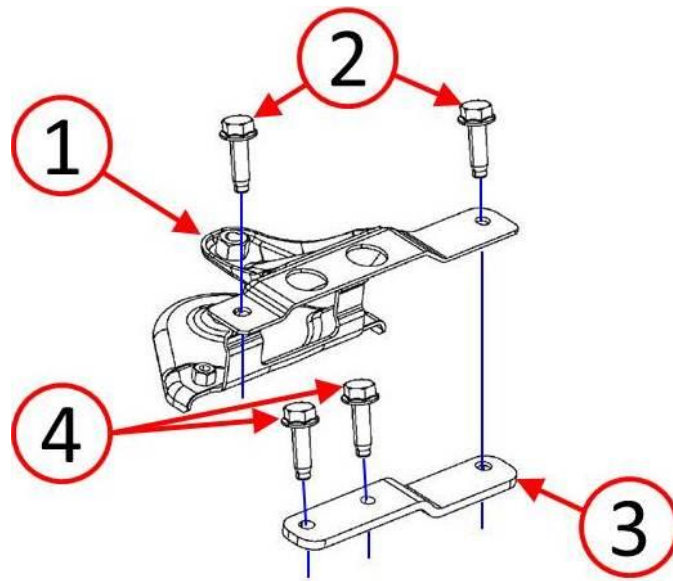

Fig. 3 Rear Engine Mount Replacement

- 1 - Rear Engine Mount Bracket
- 2 - Rear Engine Mount Bracket Fasteners
- 3 - Upper Engine Mount Bracket
- 4 - Upper Engine Mount Bracket Fasteners

POLICY:

Reimbursable within the provisions of the warranty.

TIME ALLOWANCE:

Labor Operation No:	Description	Skill Category	Amount
09-40-20-92	Inspect Rear Engine Mount Bracket (2 - Skilled)	1 - Engine Repair	0.3 Hrs.
09-40-20-93	Inspect And Replace Rear Engine Mount Bracket (2 - Skilled)	1 - Engine Repair	1.1 Hrs.

FAILURE CODE:

ZZ	Service Action
----	----------------