

TECHNICAL BULLETIN
J044NAS1
28 OCT 2014



© Jaguar Land Rover North America, LLC

NOTE: The information in Technical Bulletins is intended for use by trained, professional Technicians with the knowledge, tools, and equipment required to do the job properly and safely. It informs these Technicians of conditions that may occur on some vehicles, or provides information that could assist in proper vehicle service. The procedures should not be performed by 'do-it-yourselfers'. If you are not a Retailer, do not assume that a condition described affects your vehicle. Contact an authorized Jaguar service facility to determine whether this bulletin applies to a specific vehicle.

SECTION: 100-00

Safety Recall: Engine Front Ancillary Fixings

AFFECTED VEHICLE RANGE:

F-TYPE (X152)

Model Year: 2015
VIN: K17144-K18548

XF (X250)

Model Year: 2015
VIN: U48681-U54800

XJ Range (X351)

Model Year: 2015
VIN: V76489-V77854

MARKETS:

CONDITION SUMMARY:

This Safety Recall supersedes Update Prior to Sale UPS7514 with immediate effect.

Situation: A potential issue has been identified on a limited number of 2015 model year F-TYPE (X152), XF (X250), and XJ (X351) vehicles with the assembly processes used in the installation of the Primary drive belt and associated front-of-engine components including the Power Steering pump and Generator fixings. Fixings relating to Primary drive belt idler and tensioners, as well as the air conditioning compressor mounting fixings, may become loose or detached and lead to the Primary drive belt slipping or falling off. The Power Steering pump pulley may detach or the Battery Positive Cable fixing to Generator may become loose due to the fixings not being correctly installed.

Action: Retailers are required to **HOLD** only affected vehicles that are within your control and refrain from releasing the vehicles for new or used vehicle sale pending completion of the rework action detailed in this Technical Bulletin. Unsold vehicles should have this performed as part of the Pre-Delivery Inspection (PDI) process but **must** have it completed prior to vehicle handover to the customer. Affected vehicles already in the hands of customers should be updated at the next available opportunity.

PARTS:

No parts required

SPECIAL TOOLS:

Refer to Workshop Manual / Service Instruction for any required tools

WARRANTY:



NOTE: Check DDW to ensure that a vehicle is affected by this program prior to undertaking any rework action. Repair procedures are under constant review, and therefore times / prices are subject to change; those quoted here must be taken as guidance only. Refer to TOPiX to obtain the latest repair time. At the time of confirming a booking for vehicle repair, ensure that all outstanding Service Actions are identified to ensure the correct parts are available and adequate workshop time is allocated for repairs to be completed at one visit.

Warranty claims must be submitted quoting Program Code 'J044' together with the relevant Option Code from the table. The SRO and part information listed have been included for information only. The Option Code(s) that allows for the drive in / drive out allowance may only be claimed if the vehicle is brought into the workshop for this action alone to be undertaken.

Warranty claims must be submitted for payment within 30 calendar days of completion of the repair.

PROGRAM CODE	OPTION CODE	DESCRIPTION	SRO	TIME (HOURS)
		Engine auxiliary component torque - Check	12.41.89	F-TYPE - 1.70 XF - 2.0L GTDi, 5.0L S/C V8 - 1.10

J044	B			XF - 3.0L S/C V6 - RWD - 1.20 XJ - 3.0L S/C V6 - RWD - 1.20 XJ - 5.0L S/C V8 - 1.20
J044	C	Engine auxiliary component torque - Check Drive in/drive out	12.41.89 10.10.10	F-TYPE - 1.70 XF - 2.0L GTDi, 5.0L S/C V8 - 1.10 XF - 3.0L S/C V6 - RWD - 1.20 XJ - 3.0L S/C V6 - RWD - 1.20 XJ - 5.0L S/C V8 - 1.20 ALL - 0.10
J044	F	Engine auxiliary component torque - Check	12.41.89/01	XF - 3.0L S/C V6 - AWD - 1.50 XJ - 3.0L S/C V6 - AWD - 1.40
J044	G	Engine auxiliary component torque - Check Drive in/drive out	12.41.89/01 10.10.10	XF - 3.0L S/C V6 - AWD - 1.50 XJ - 3.0L S/C V6 - AWD - 1.40 ALL - 0.10

Normal Warranty policies and procedures apply

SERVICE INSTRUCTION 'A': 2.0L GTDi Petrol XF Only



NOTE: Illustrations may show components removed for clarity.

1. Disconnect the battery ground cable (see TOPIx Workshop Manual, section 414-01).
2. Remove the engine cover (see TOPIx Workshop Manual, section 501-05).
3. Tighten the Power Steering pump retaining bracket fixings.

1. Torque: 21Nm

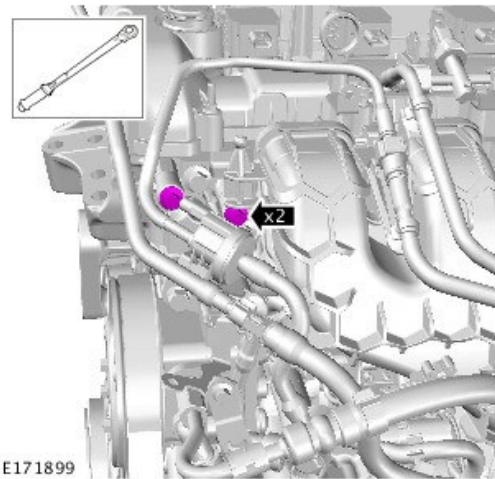

4. Tighten the Power Steering pump fixings.

1. Torque: 21Nm

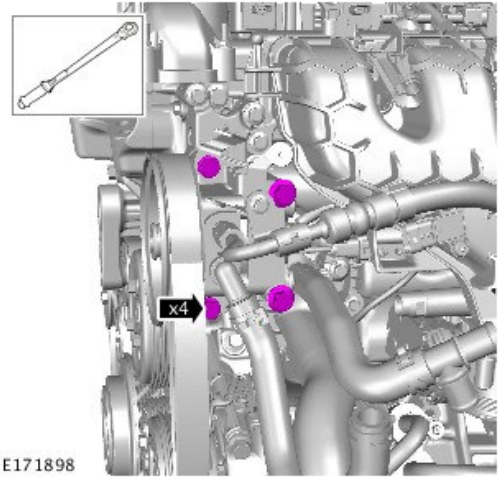

E171898

5. Tighten the Primary drive belt tensioner fixing.

1. Torque: 21Nm

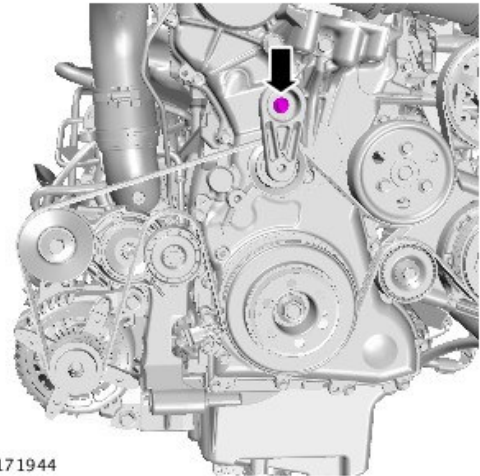

E171944

6. Tighten the generator fixings.

1. Torque: 40Nm

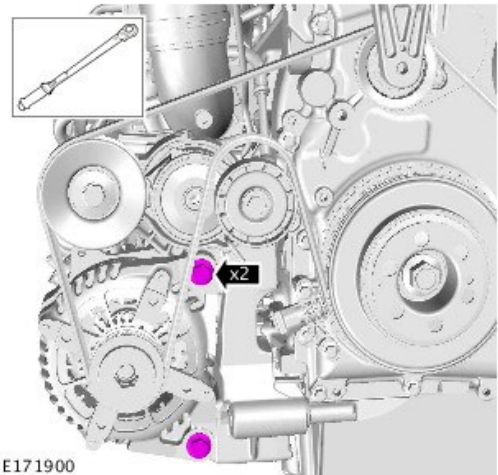

E171900

7. Tighten the Primary drive belt idler pulley fixings.

1. Torque: 40Nm

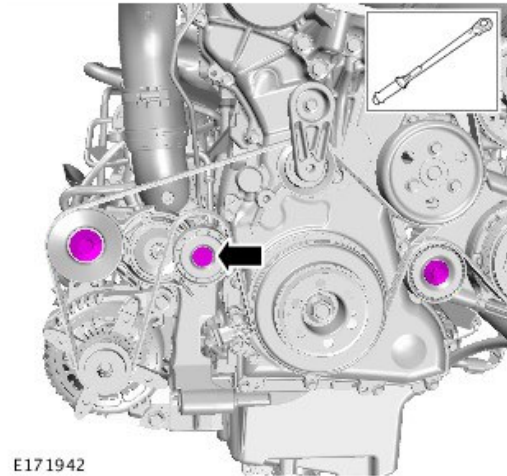

8. Tighten the Air Conditioning compressor and Air Conditioning compressor bracket top fixings.

1. Torque: 21Nm

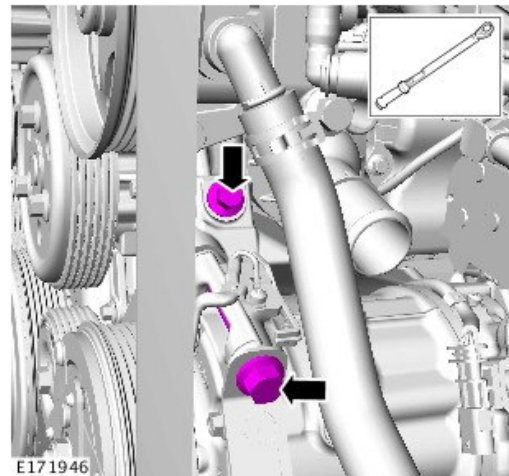

9.  **WARNING: Make sure to support the vehicle with axle stands.**

Raise and support the vehicle.

10. Remove the Air deflector (see TOPIx Workshop Manual, section 501-02).

11. Remove the front left-hand lower splash shield for access.

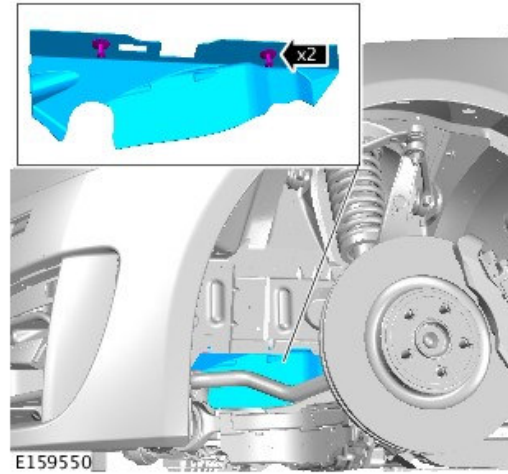

12. Position aside the transmission oil cooler.

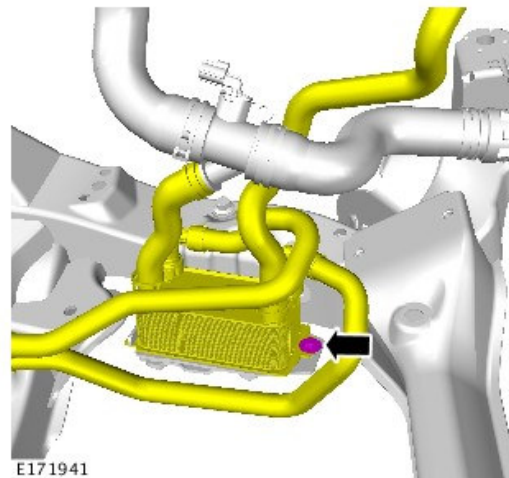

13. Remove the transmission oil cooler bracket.

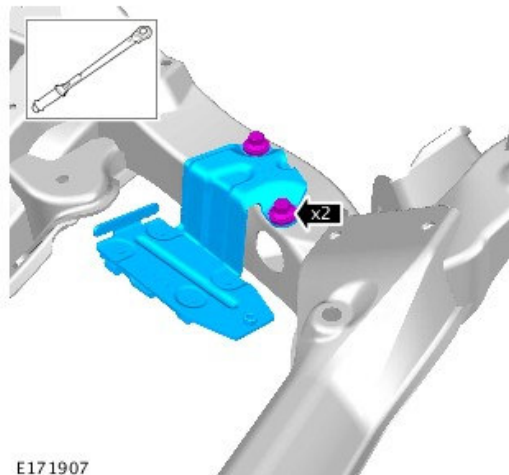

14. Tighten the Air Conditioning compressor bracket lower fixing.

1. Torque: 21Nm

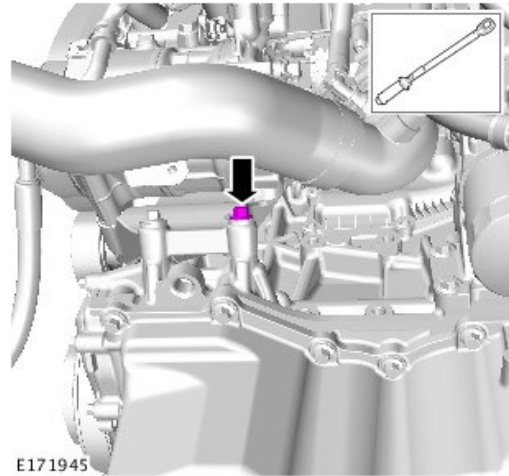

15. Tighten the Air Conditioning compressor rear fixing and left-hand engine mount lower fixings.

1. Air Conditioning compressor: 21Nm.
2. Engine mount: 40Nm.

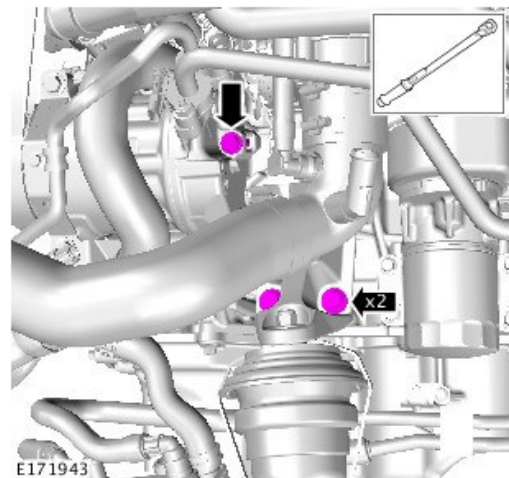

16. Remove the front right-hand lower splash shield for access.

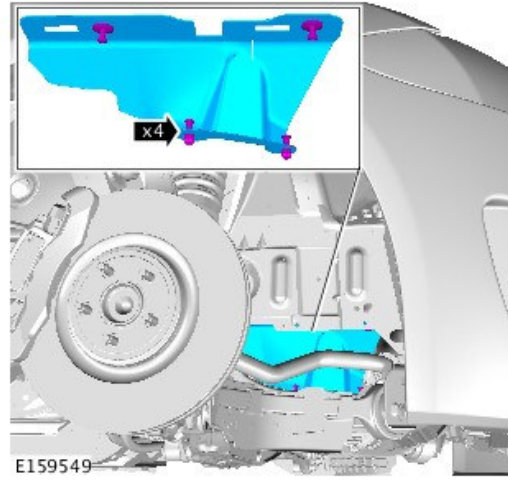

17. Loosen but do not fully remove the catalytic converter heat shield fixings.

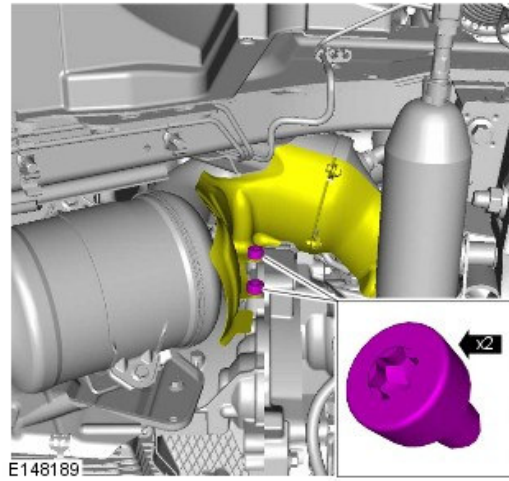

18. Remove the turbocharger heat shield.

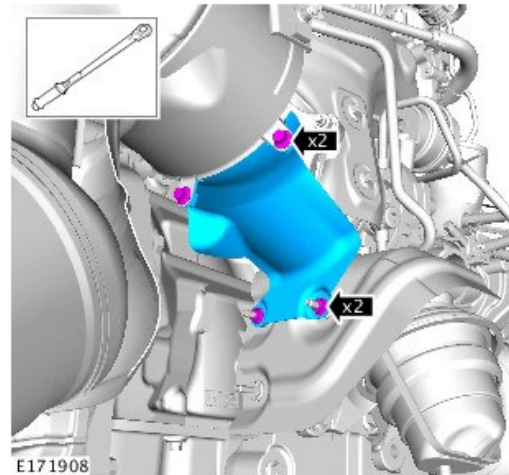

19. Remove the right-hand engine mount heat shield.

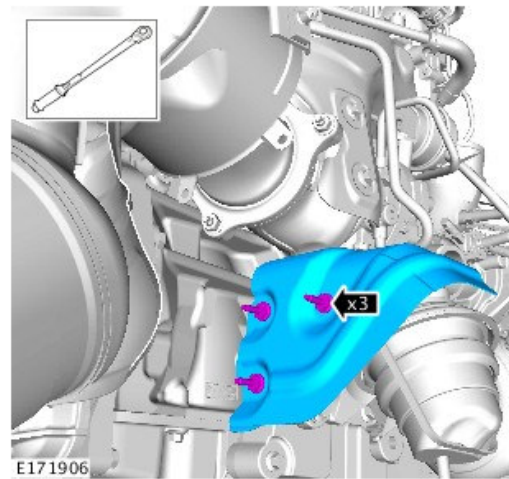

20. Tighten the generator bracket upper fixings.

1. Torque: 40Nm

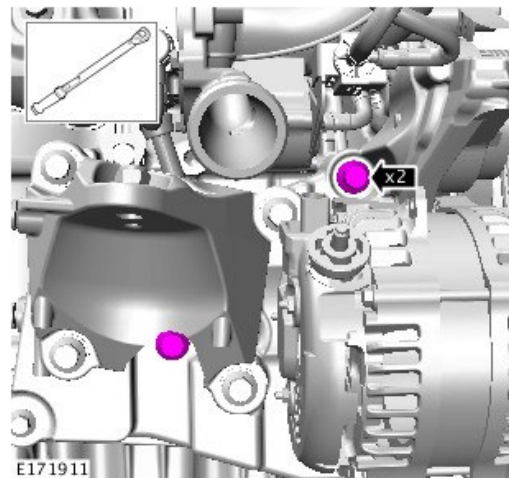

21. Tighten the right-hand engine mount lower fixings.

1. Torque: 40Nm

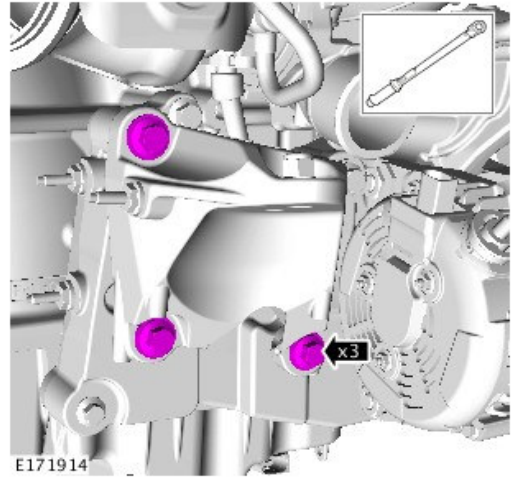

22. Tighten the generator bracket lower fixing.

1. Torque: 21Nm

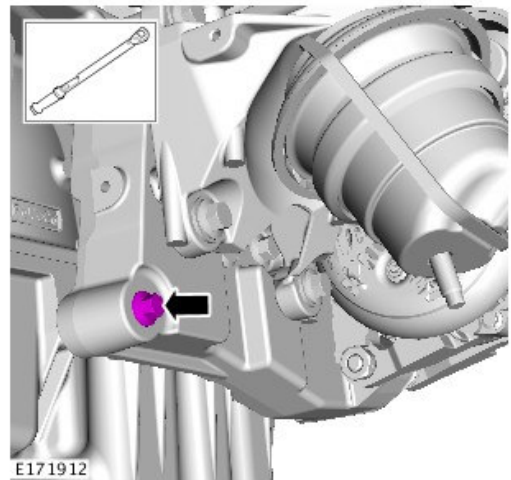

23. Tighten the generator bracket front fixing.

1. Torque: 21Nm

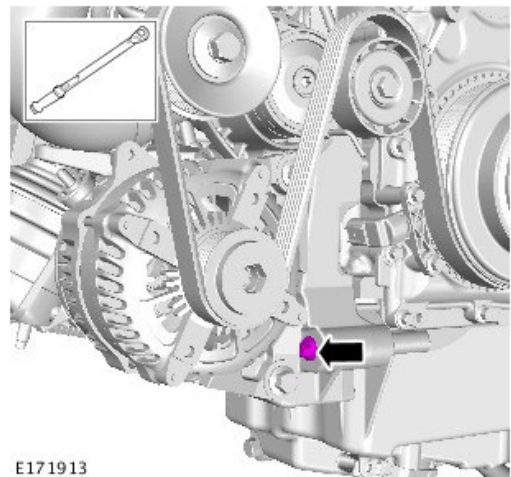

24. Check the generator battery positive cable is secure and positioned correctly.

1. Tighten the generator battery positive cable fixing.
2. Torque: 9Nm

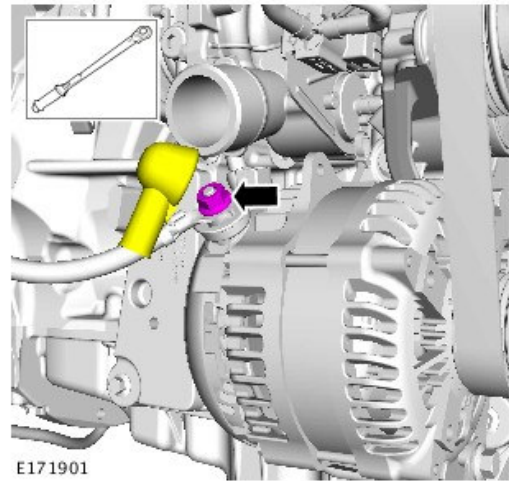

25. Tighten the transmission fixings.

1. Torque: 40Nm

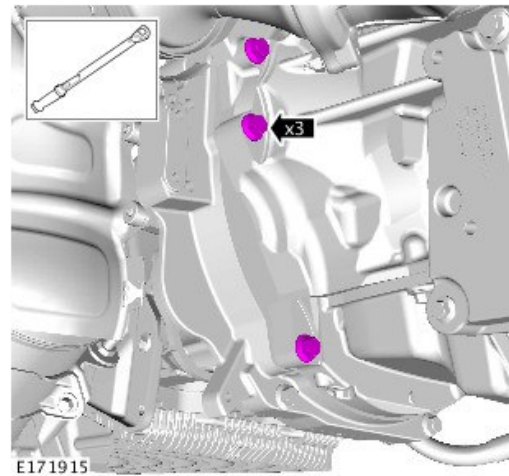

26. Tighten the transmission Emergency Park Release (EPR) fixing.

1. Torque: 10Nm

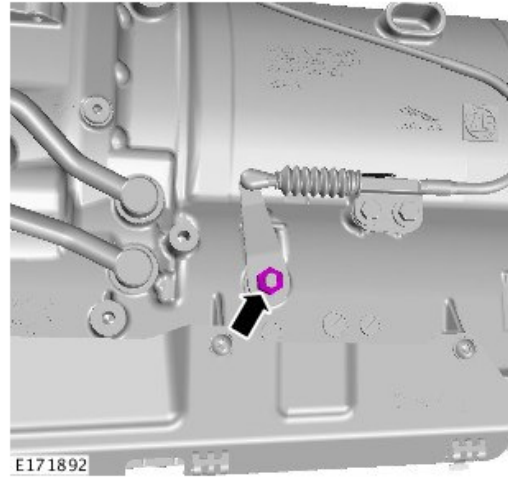

27. Install the right-hand engine mount heat shield.

1. Torque: 11Nm

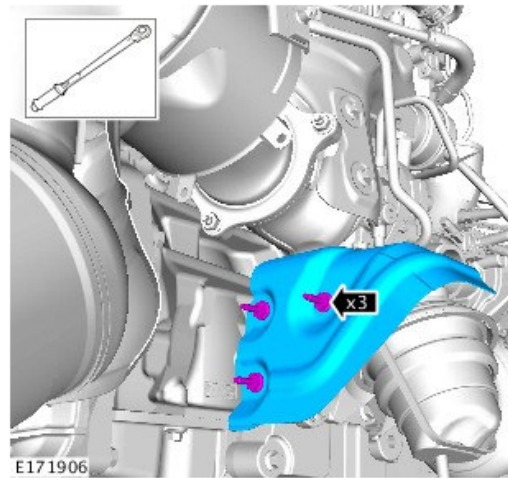

28. Install the turbocharger lower heat shield.

1. Torque: 11Nm

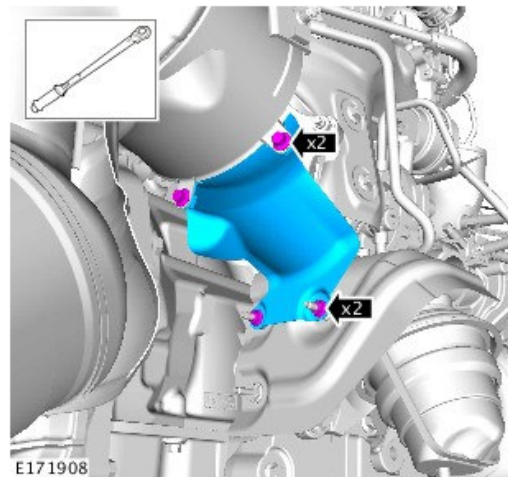

29. Tighten the catalytic converter heat shield fixings.

1. Torque: 35Nm

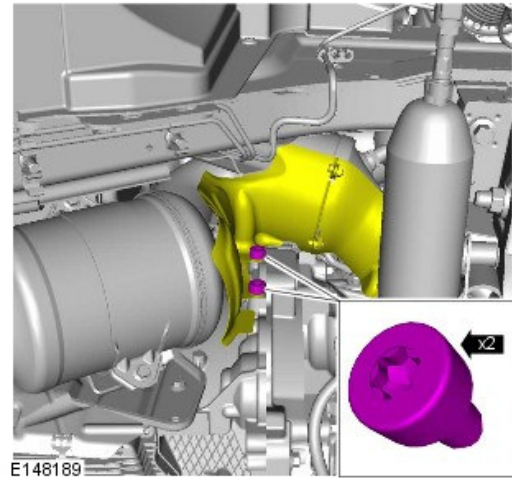

30. Install the transmission oil cooler bracket.

1. Torque: 25Nm

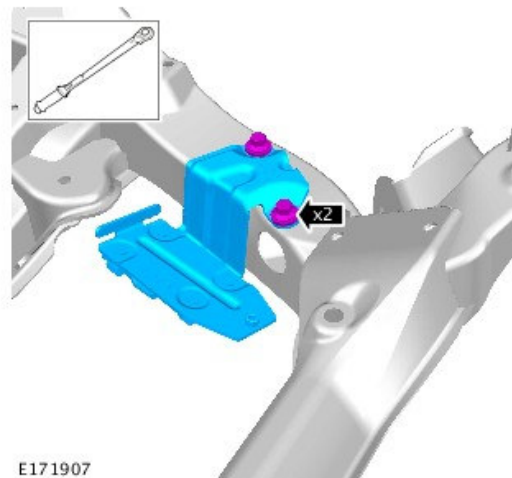

31. Install the transmission oil cooler.

1. Torque: 5Nm

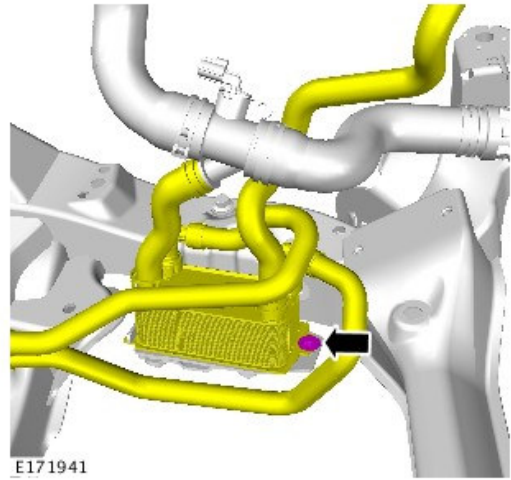

32. Install the front right-hand lower splash shield.

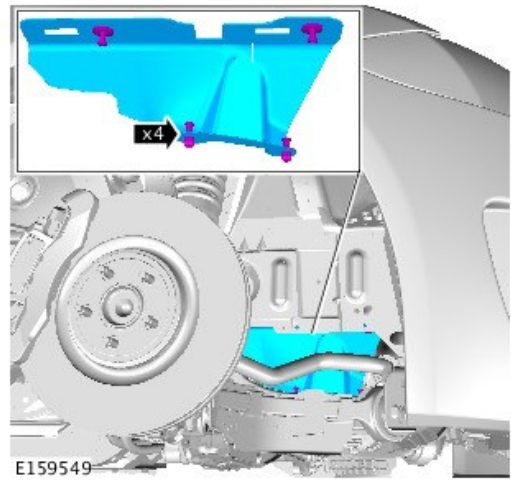

33. Install the front left-hand side lower splash shield.

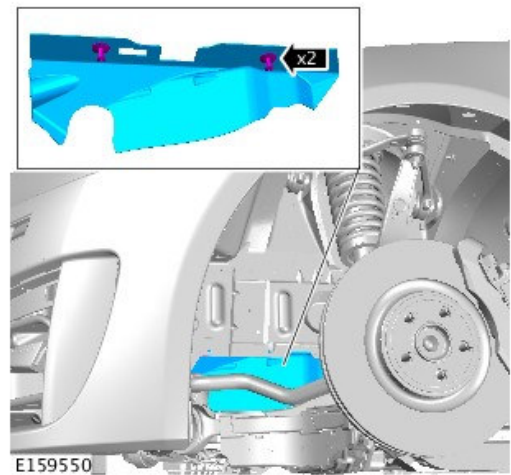

34. Install the Air deflector (see TOPIx Workshop Manual, section 501-02).

35. Lower the vehicle.

36. Check the fuel line connections are secure.

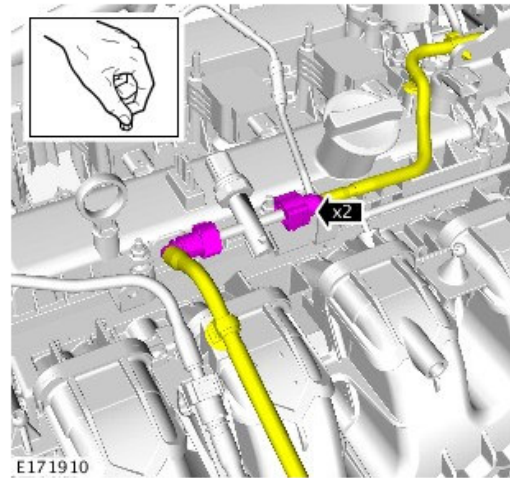

37. Tighten the high pressure fuel pump protection bracket fixing.

1. Torque: 8Nm

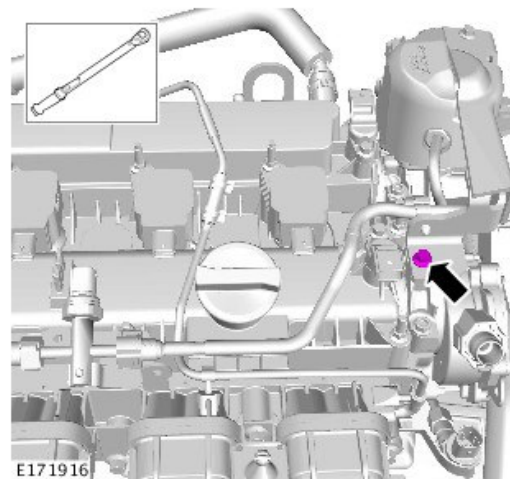

38. Install the engine cover (see TOPIx Workshop Manual, section 501-05).

39. Connect the battery ground cable (see TOPIx Workshop Manual, section 414-01).

SERVICE INSTRUCTION 'B':

All Vehicles Except 2.0L GTDi Petrol XF

 **NOTE: Illustrations may show components removed for clarity.**

1. Disconnect the battery ground cable (see TOPIx Workshop Manual, section 414-01).

3.0L V6 Supercharged Petrol F-TYPE Only

2. Remove the air cleaner outlet pipe T-connector (see TOPIx Workshop Manual, section 303-12A).
3. Remove the air cleaner outlet intermediate pipe left-hand (see TOPIx Workshop Manual, section 303-12A).
4. Remove the air cleaner outlet intermediate pipe right-hand (see TOPIx Workshop Manual, section 303-12A).

5.0L V8 Supercharged Petrol F-TYPE Only

5. Remove the air cleaner outlet pipe T-connector (see TOPIx Workshop Manual, section 303-12B).
6. Remove the air cleaner outlet intermediate pipe left-hand (see TOPIx Workshop Manual, section 303-12B).
7. Remove the air cleaner outlet intermediate pipe right-hand (see TOPIx Workshop Manual, section 303-12B).

3.0L V6 Supercharged Petrol XF Only

8. Remove the air cleaner left-hand (see TOPIx Workshop Manual, section 303-12D).
9. Remove the air cleaner outlet pipe T-connector (see TOPIx Workshop Manual, section 303-12D).
10. Remove the air cleaner outlet pipe left-hand (see TOPIx Workshop Manual, section 303-12D).

5.0L V8 Supercharged Petrol XF Only

11. Remove the air cleaner left-hand (see TOPIx Workshop Manual, section 303-12C).
12. Remove the air cleaner outlet pipe T-connector (see TOPIx Workshop Manual, section 303-12C).
13. Remove the air cleaner outlet pipe left-hand (see TOPIx Workshop Manual, section 303-12C).

3.0L V6 Supercharged Petrol XJ Only

14. Remove the air cleaner left-hand (see TOPIx Workshop Manual, section 303-12C).
15. Remove the air cleaner outlet pipe T-connector (see TOPIx Workshop Manual, section 303-12C).
16. Remove the air cleaner outlet pipe left-hand (see TOPIx Workshop Manual, section 303-12C).

5.0L V8 Supercharged XJ Only

17. Remove the air cleaner left-hand (see TOPIx Workshop Manual, section 303-12B).
18. Remove the air cleaner outlet pipe T-connector (see TOPIx Workshop Manual, section 303-12B).
19. Remove the air cleaner outlet pipe left-hand (see TOPIx Workshop Manual, section 303-12B).

All 3.0L V6 Supercharged, 5.0L V8 Supercharged

20. Release and carefully position aside the thermostat housing to gain access.

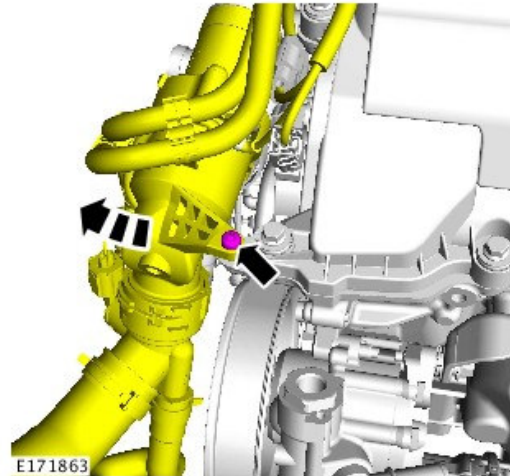

21. Using a suitable tool, lock the Power Steering pulley as shown.

- Tighten the three (3) Power Steering pulley fixings
- Torque: 21Nm

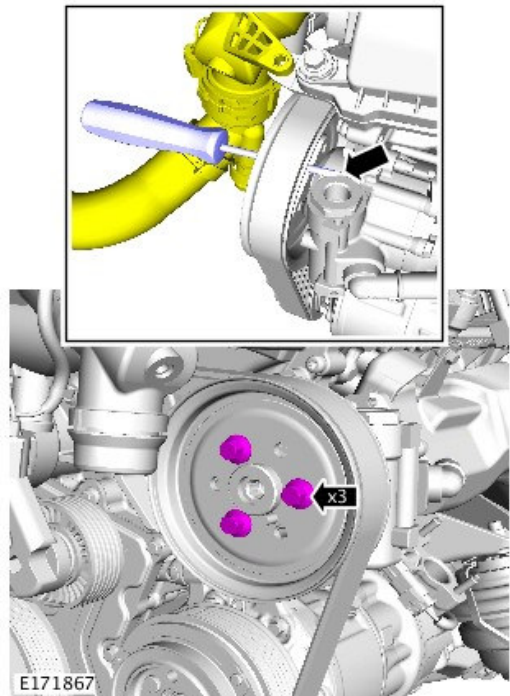

22. Install the thermostat housing.

- Torque: 10Nm

23. Using a suitable tool, remove the protective caps and tighten the Primary drive belt idler pulley fixings.

- Torque: 40Nm

- Install the protective caps

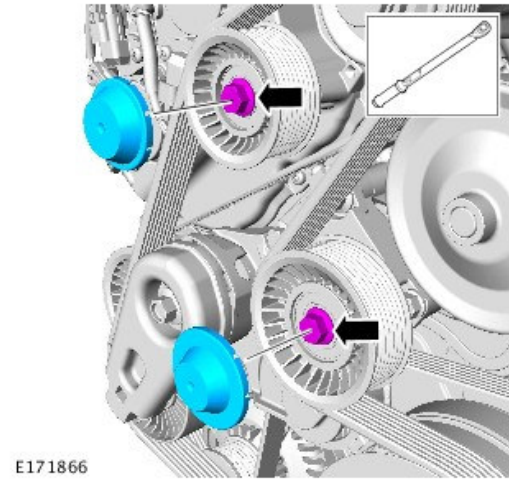

24. Tighten the Secondary (supercharger) drive belt tensioner bracket fixings.

- Torque: 21Nm

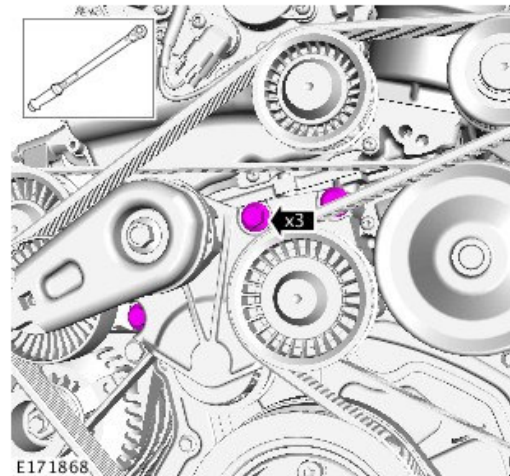

All 3.0L V6 Supercharged, 5.0L V8 Supercharged

25. Tighten the Primary drive belt tensioner fixing.

- Torque: 40Nm

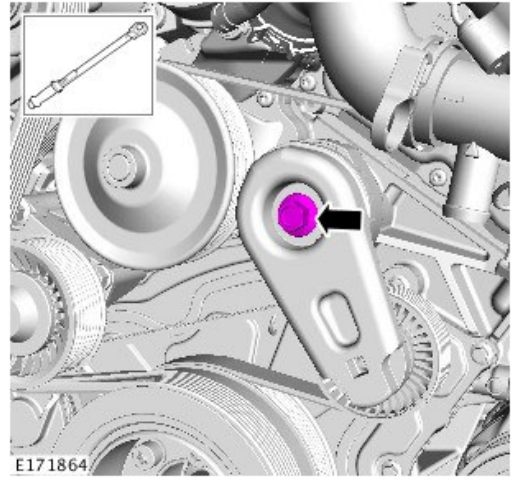

26. Check the left-hand Variable Camshaft Timing (VCT) solenoid electrical connectors are secure.

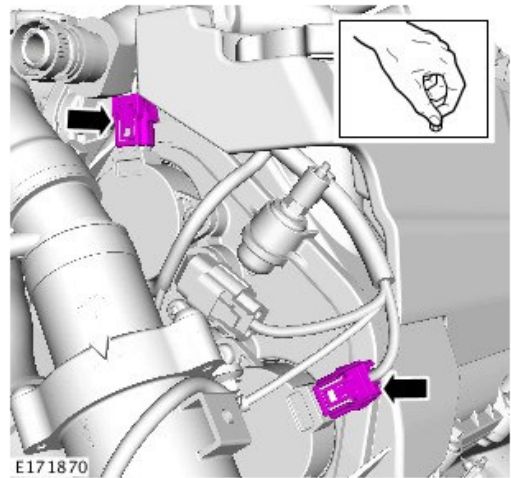

27. Check the right-hand Variable Camshaft Timing (VCT) solenoid electrical connectors are secure.

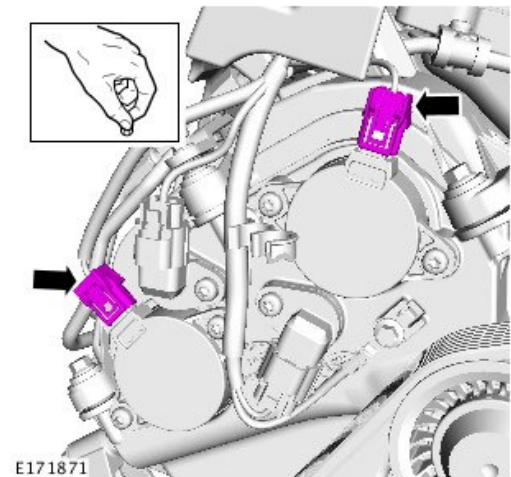

3.0L V6 Supercharged Petrol F-TYPE Only

- 28. Install the air cleaner outlet intermediate pipe right-hand (see TOPIx Workshop Manual, section 303-12A).
- 29. Install the air cleaner outlet intermediate pipe left-hand (see TOPIx Workshop Manual, section 303-12A).
- 30. Install the air cleaner outlet pipe T-connector (see TOPIx Workshop Manual, section 303-12A).

5.0L V8 Supercharged Petrol F-TYPE Only

- 31. Install the air cleaner outlet intermediate pipe right-hand (see TOPIx Workshop Manual, section 303-12B).
- 32. Install the air cleaner outlet intermediate pipe left-hand (see TOPIx Workshop Manual, section 303-12B).
- 33. Install the air cleaner outlet pipe T-connector (see TOPIx Workshop Manual, section 303-12B).

3.0L V6 Supercharged Petrol XF Only

- 34. Install the air cleaner outlet pipe left-hand (see TOPIx Workshop Manual, section 303-12D).
- 35. Install the air cleaner outlet pipe T-connector (see TOPIx Workshop Manual, section 303-12D).
- 36. Install the air cleaner left-hand (see TOPIx Workshop Manual, section 303-12D).

5.0L V8 Supercharged Petrol XF Only

- 37. Install the air cleaner outlet pipe left-hand (see TOPIx Workshop Manual, section 303-12C).
- 38. Install the air cleaner outlet pipe T-connector (see TOPIx Workshop Manual, section 303-12C).
- 39. Install the air cleaner left-hand (see TOPIx Workshop Manual, section 303-12C).

3.0L V6 Supercharged Petrol XJ Only

- 40. Install the air cleaner outlet pipe left-hand (see TOPIx Workshop Manual, section 303-12C).
- 41. Install the air cleaner outlet pipe T-connector (see TOPIx Workshop Manual, section 303-12C).
- 42. Install the air cleaner left-hand (see TOPIx Workshop Manual, section 303-12C).

5.0L V8 Supercharged XJ Only

- 43. Install the air cleaner outlet pipe left-hand (see TOPIx Workshop Manual, section 303-12B).
- 44. Install the air cleaner outlet pipe T-connector (see TOPIx Workshop Manual, section 303-12B).
- 45. Install the air cleaner left-hand (see TOPIx Workshop Manual, section 303-12B).

All 3.0L V6 Supercharged, 5.0L V8 Supercharged

46.  **WARNING: Make sure to support the vehicle with axle stands.**

Raise and support the vehicle (see TOPIx Workshop Manual, section 100-02).

47. Remove the engine under tray (see TOPIx Workshop Manual, section 501-02).

3.0L V6 Supercharged and 5.0L V8 Supercharged Petrol F-TYPE Only

48. Remove the radiator splash shield (see TOPIx Workshop Manual, section 501-02).

3.0L V6 Supercharged and 5.0L V8 Supercharged Petrol XF and 3.0L V6 Supercharged, 5.0L V8 Supercharged XJ Only

49. Turn the steering to gain access to the front right-hand wheel arch area.

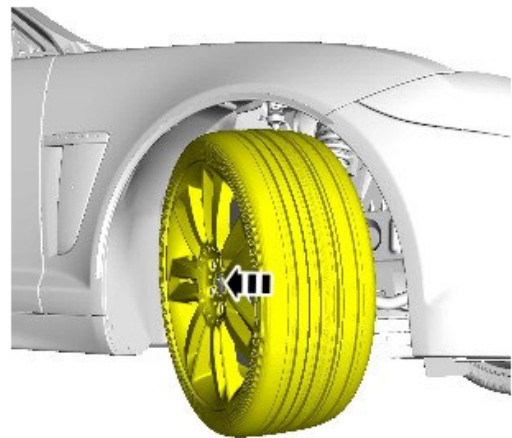

E171897

50. Remove the front right-hand lower splash shield.

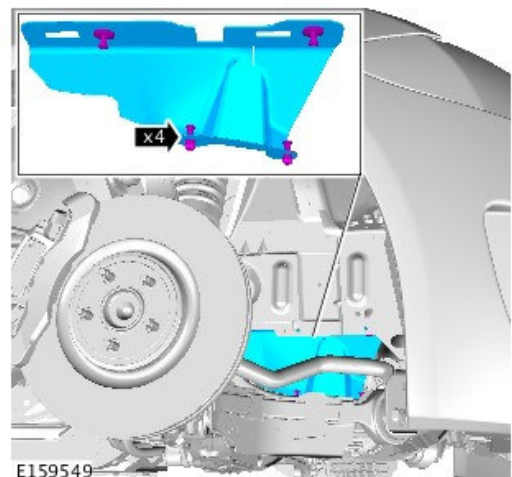

E159549

3.0L V6 Supercharged Petrol XF and XJ AWD Only

51. Release Air Conditioning pipe.

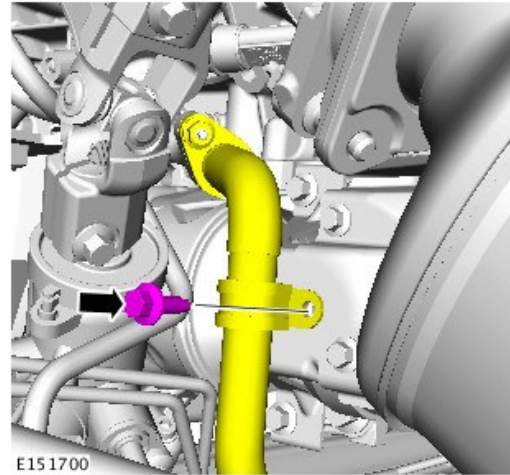

52. Release the front driveshaft heat shield.

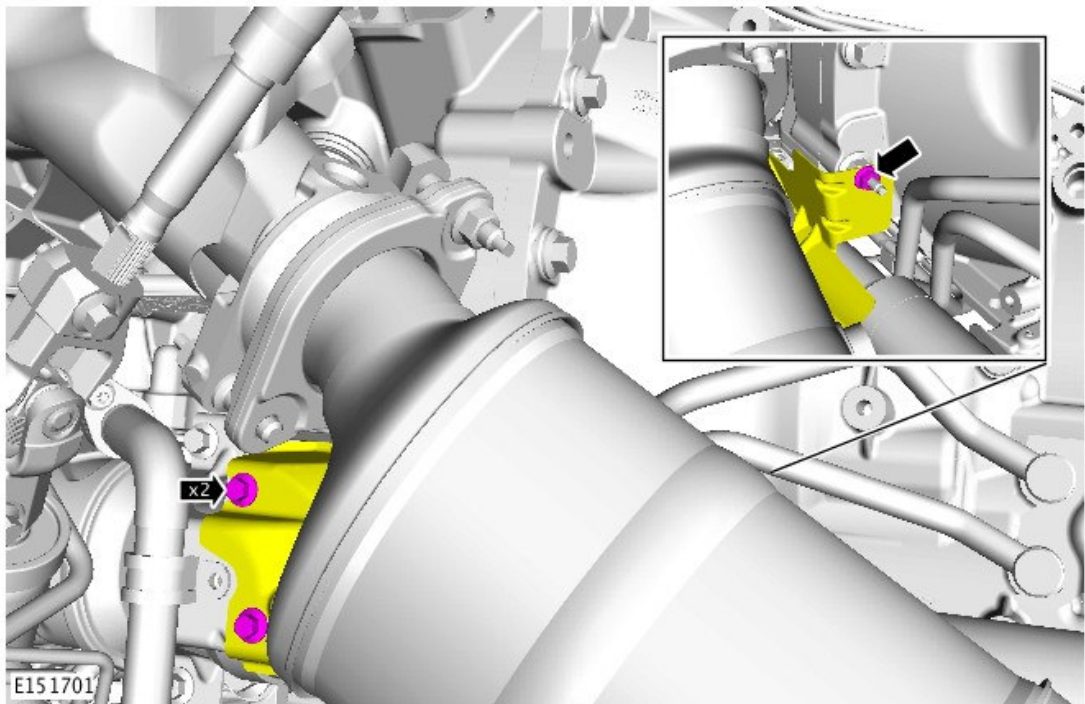

53. Remove the front driveshaft heat shield support bracket.

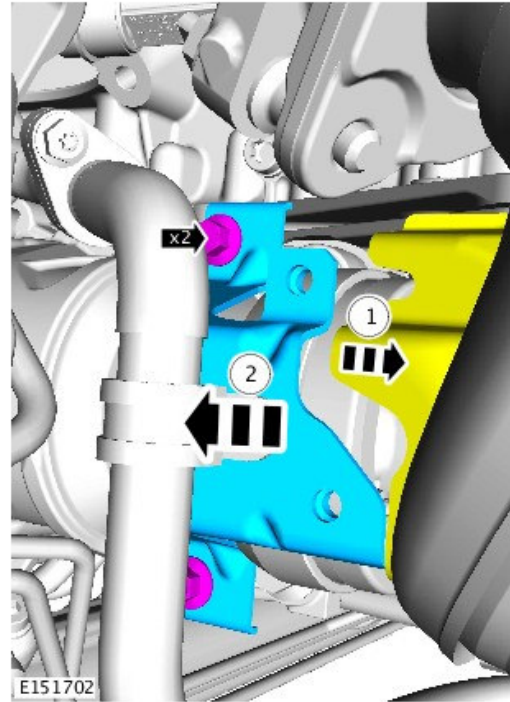

54. Tighten front differential fixings.

- Torque: 98Nm

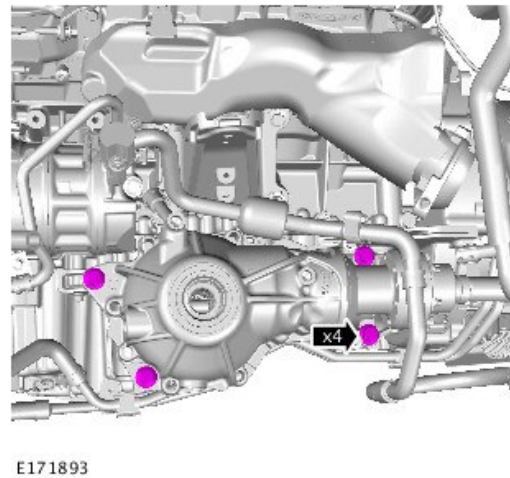

55. Tighten the front halfshaft support bracket fixings.

- Torque: 21Nm

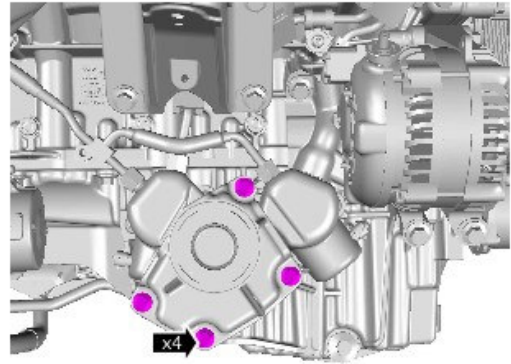

E171894

56. Install the front driveshaft heat shield bracket.

1. Torque 25Nm

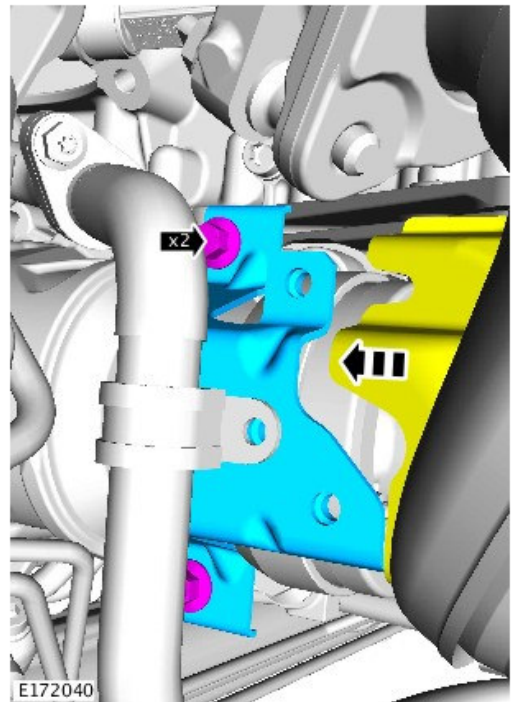

E172040

57. Install the front driveshaft heat shield.

1. Torque 9Nm

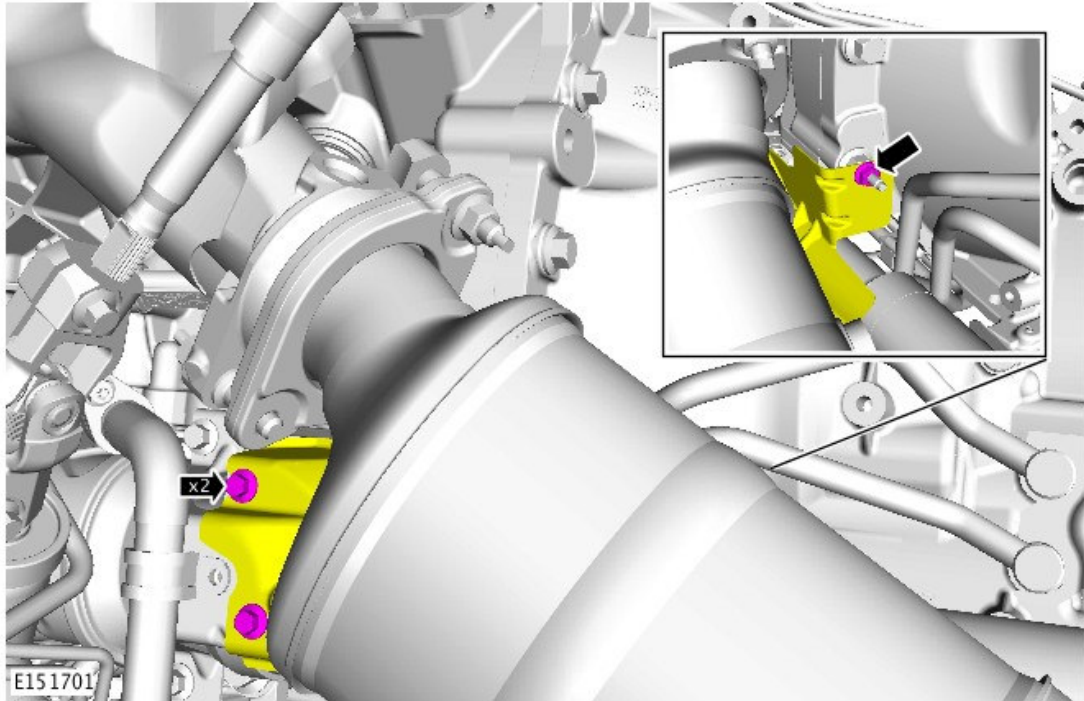

58. Install the Air Conditioning pipe.

1. Torque 9Nm

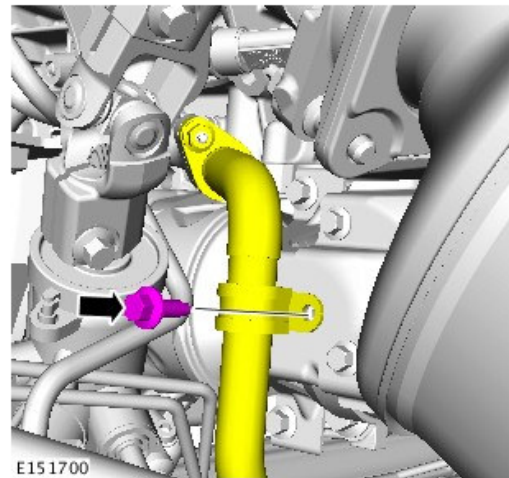

All 3.0L V6 Supercharged, 5.0L V8 Supercharged

59. Tighten the Primary drive belt idler pulley bracket fixings.

- Torque: 21Nm

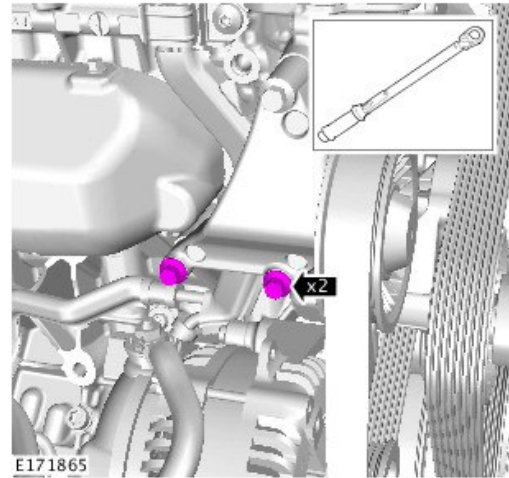

60. Tighten the generator fixings.

- Torque: 40Nm

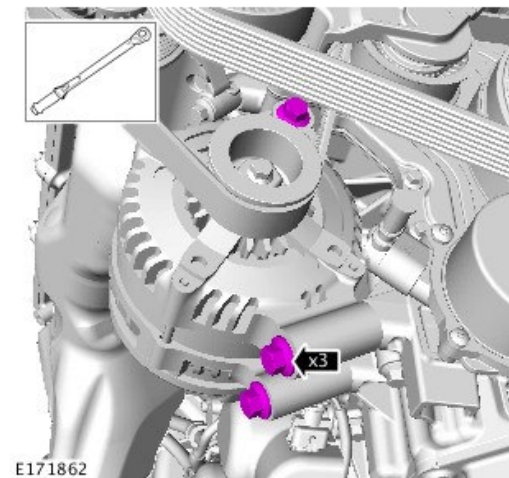

61. Check the generator battery positive cable is secure and positioned correctly.

1. Tighten the generator battery positive cable fixing.
2. Torque: 9Nm

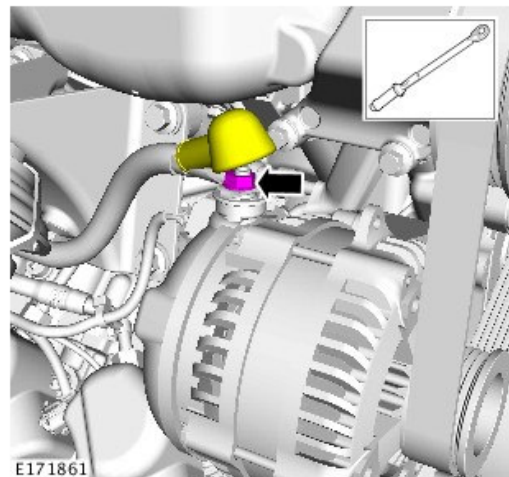

62. Check the brake vacuum pump hose connection is secure.

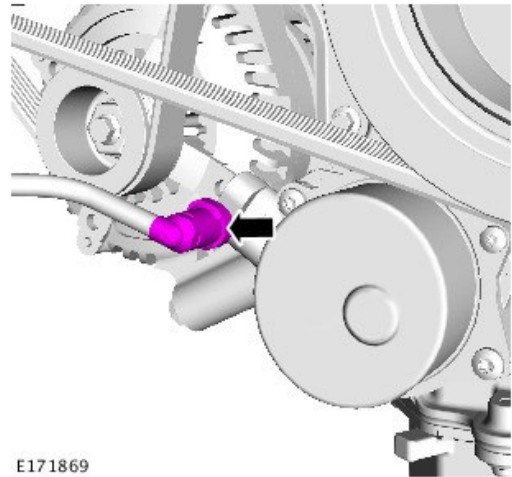

63. Tighten the Air Conditioning compressor front fixings.

- Torque: 21Nm

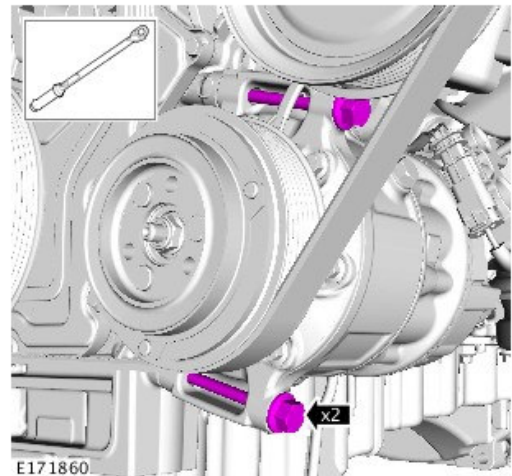

64. Tighten the transmission Emergency Park Release (EPR) fixing.

- Torque: 10Nm

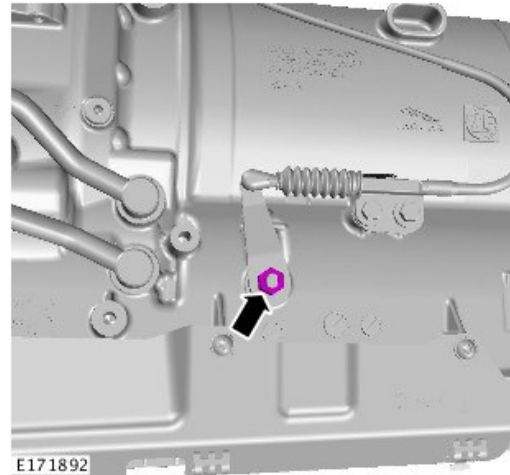

3.0L V6 Supercharged and 5.0L V8 Supercharged XF and 3.0L V6 Supercharged, 5.0L V8 Supercharged XJ Only

65. Install the right-hand lower splash shield.

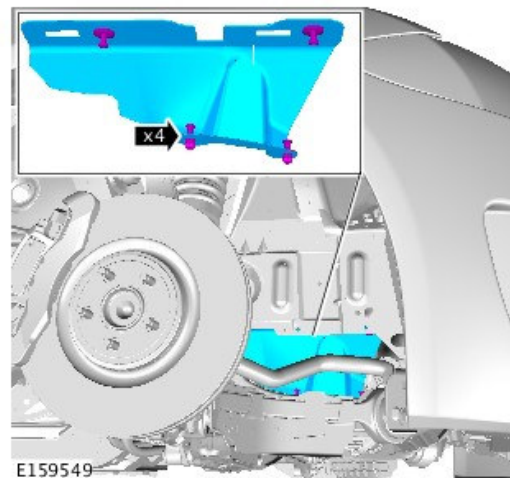

All 3.0L V6 Supercharged, 5.0L V8 Supercharged

66. Install the engine under tray (see TOPIx Workshop Manual, section 501-02).

3.0L V6 Supercharged and 5.0L V8 Supercharged Petrol F-TYPE Only

67. Install the radiator splash shield (see TOPIx Workshop Manual, section 501-02).

All 3.0L V6 Supercharged, 5.0L V8 Supercharged

68. Lower the vehicle.

69. Connect the battery ground cable (see TOPIx Workshop Manual, section 414-01).