

TECHNICAL BULLETIN  
J047 UPS8014-3bNAS1  
31 OCT 2014



© Jaguar Land Rover North America, LLC

NOTE: The information in Technical Bulletins is intended for use by trained, professional Technicians with the knowledge, tools, and equipment required to do the job properly and safely. It informs these Technicians of conditions that may occur on some vehicles, or provides information that could assist in proper vehicle service. The procedures should not be performed by 'do-it-yourselfers'. If you are not a Retailer, do not assume that a condition described affects your vehicle. Contact an authorized Jaguar service facility to determine whether this bulletin applies to a specific vehicle.

Changes are highlighted in gray

**SECTION: 501-20B**

Update Prior to Sale: Seat Belt Tensioner System Connector Wiring

**AFFECTED VEHICLE RANGE:**

**F-TYPE (X152)**

**Model Year:** 2014-2015  
**VIN:** K00074-K19728

**MARKETS:**

NAS

**CONDITION SUMMARY:**

**Situation:** An issue has been identified with the wiring connecting the passenger seat belt tensioner system to the main cabin wiring harness, and it is possible that the seat belt tensioner system may not correctly sense the presence of a child restraint or very light weight occupant.

**Action:** Retailers are required to **HOLD** only affected vehicles that are within your control and refrain from releasing the vehicles for new or used vehicle sale pending completion of the rework action detailed in this Technical Bulletin. Unsold vehicles should have this performed as part of the Pre-Delivery Inspection (PDI) process but **must** have it completed prior to vehicle handover to the customer.

**PARTS:**

No parts required

**SPECIAL TOOLS:**

Refer to Workshop Manual / Service Instruction for any required tools

**WARRANTY:**



**NOTE: Check DDW to ensure that a vehicle is affected by this program prior to undertaking any rework action. Repair procedures are under constant review, and therefore times / prices are subject to change; those quoted here must be taken as guidance only. Refer to TOPIx to obtain the latest repair time. At the time of confirming a booking for vehicle repair, ensure that all outstanding Service Actions are identified to ensure the correct parts are available and adequate workshop time is allocated for repairs to be completed at one visit.**

Warranty claims must be submitted quoting Program Code '**J047**' together with the relevant Option Code from the table. The SRO and part information listed have been included for information only. The Option Code(s) that allows for the drive in / drive out allowance may only be claimed if the vehicle is brought into the workshop for this action alone to be undertaken.

This program is valid for a limited time only. Warranty claims with a repair date prior to the **30 April 2015** closure date must be submitted for payment within 30 calendar days of completion of the repair.

PROGRAM CODE	OPTION CODE	DESCRIPTION	SRO	TIME (HOURS)	PARTS / SUNDRY CODE	QTY. / VALUE
J047	B	Seat belt tensioner system connector wiring rework	05.10.50	0.50	-	-
J047	C	Seat belt tensioner system connector wiring rework	05.10.50 10.10.10	0.50 0.10	- -	- -

		Drive in/drive out				
J047	D	Seat belt tensioner system connector wiring rework Transit mode	05.10.50 86.93.93	0.50 0.20	- -	- -
J047	E	Seat belt tensioner system connector wiring rework Drive in/drive out Transit mode	05.10.50 10.10.10 86.93.93	0.50 0.10 0.20	- - -	- - -

Normal Warranty policies and procedures apply

## **SERVICE INSTRUCTION**



**NOTE: Some variation in the illustrations may occur, but the essential information is always correct.**

1. If the vehicle is in 'Transportation mode', set the vehicle to 'Normal operation mode'.

- If required, remove the transit relay.



2. **WARNING: Allow a period of 10 minutes to elapse after disconnecting the battery before undertaking any work on the Supplementary Restraint System (SRS).**

Disconnect the battery (see TOPIx Workshop Manual, section 414-01).

3. Remove the electrical connector cover for the passenger seatbelt tension sensor.

- Release the clips.

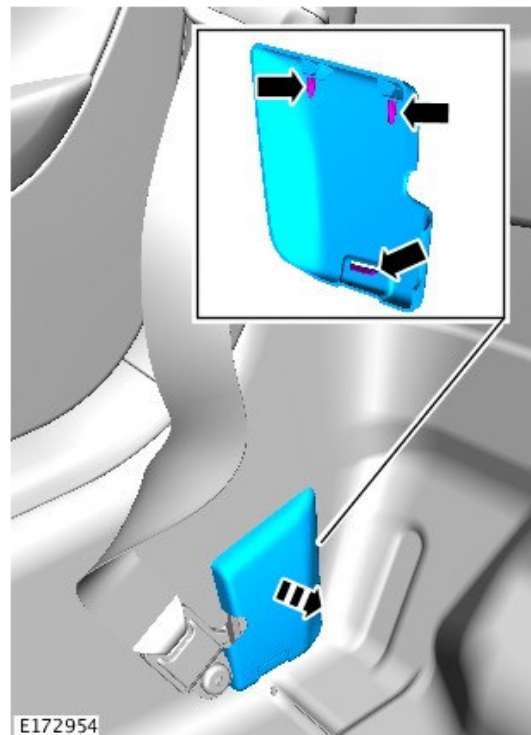

4. Release the electrical

connector  
(C3R210)  
from the  
bracket.

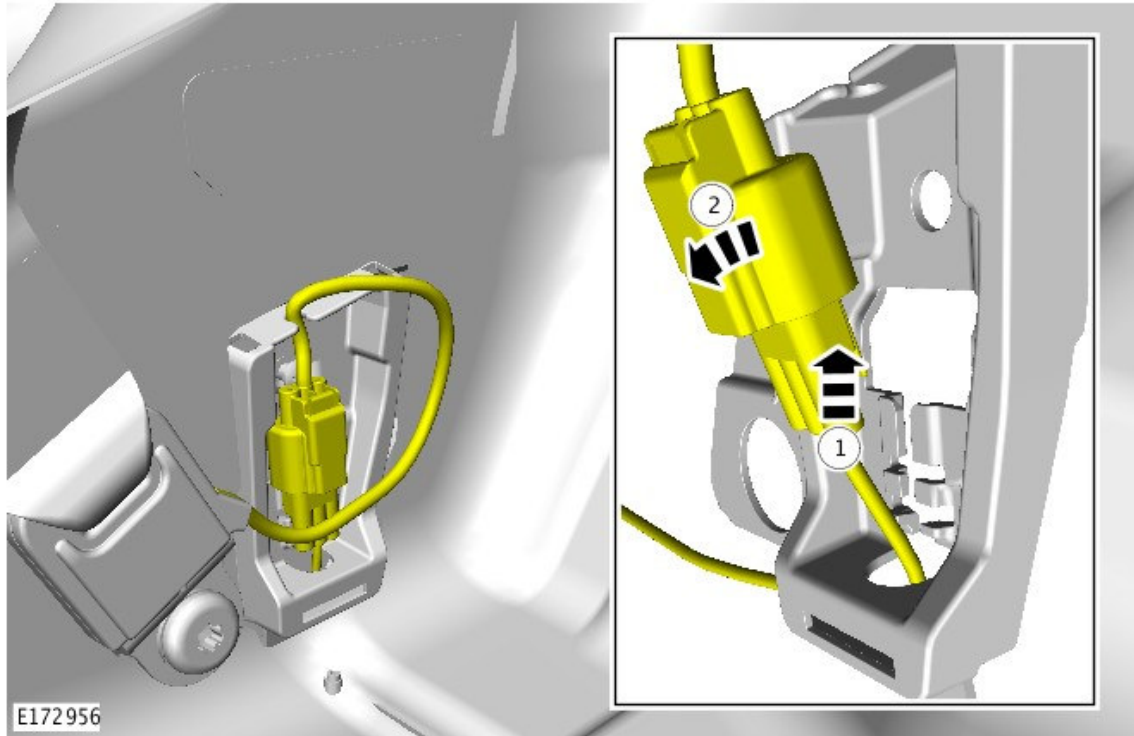

**5.** At the Seatbelt Tension Sensor side of connector C3R210, check that the electrical connector wires are positioned in the correct pin location as shown.

- If the wires are in the correct position, reverse steps 1-4 and release the vehicle.
- If the wires are not in the correct position, proceed to step 6.

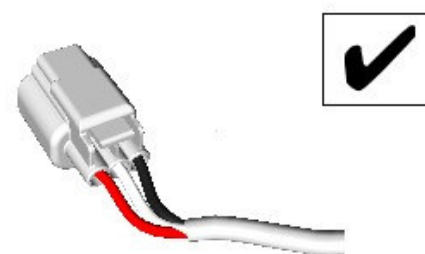
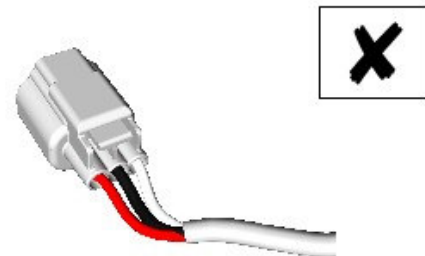

E172955

6. Disconnect the electrical connector.

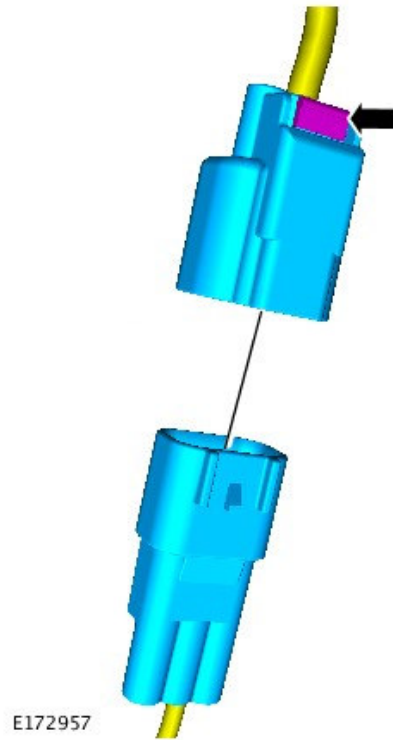

7. Using a suitable tool, remove the anti-backout device from the electrical connector.

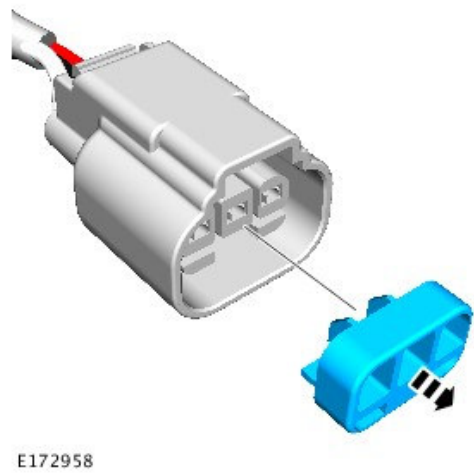

8. Using special tool 418-595, release the electrical connector.

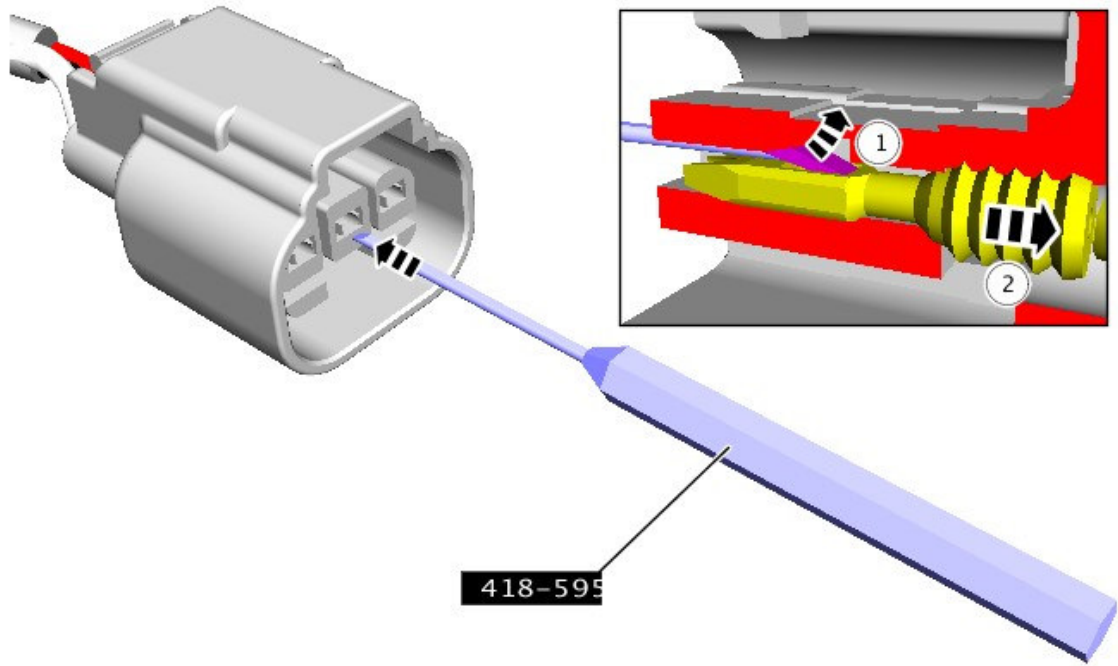

E172960

9. Using special tool 418-595, release the electrical connector.

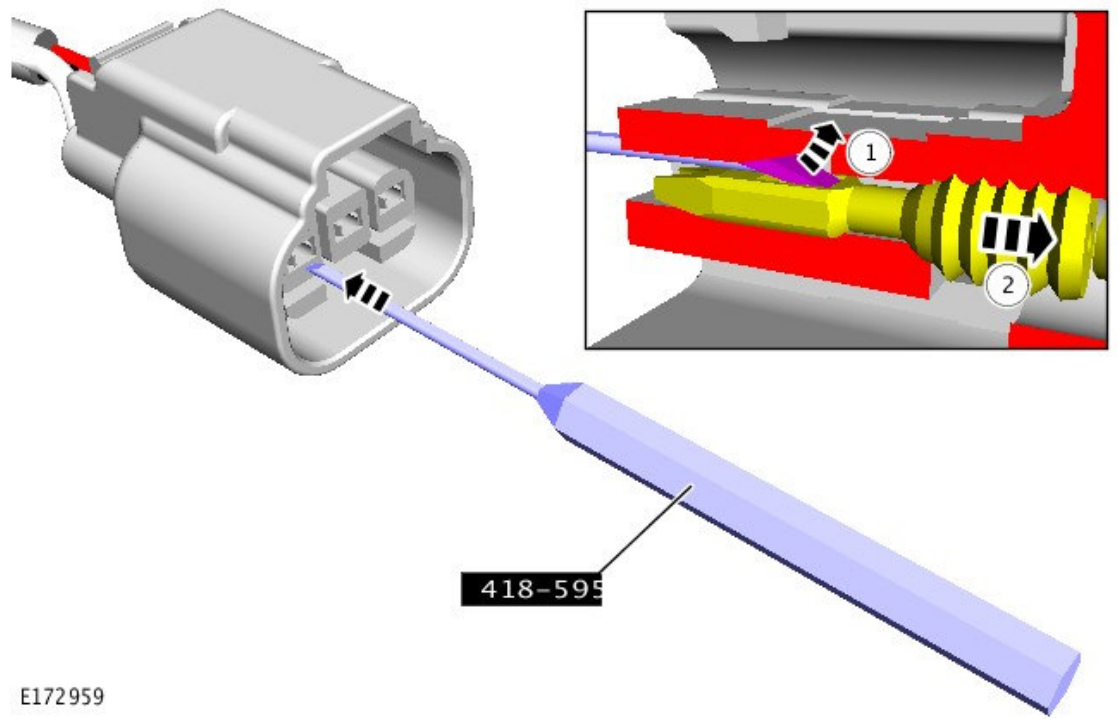

E172959

**10.** Remove the white wire electrical pin from the electrical connector.

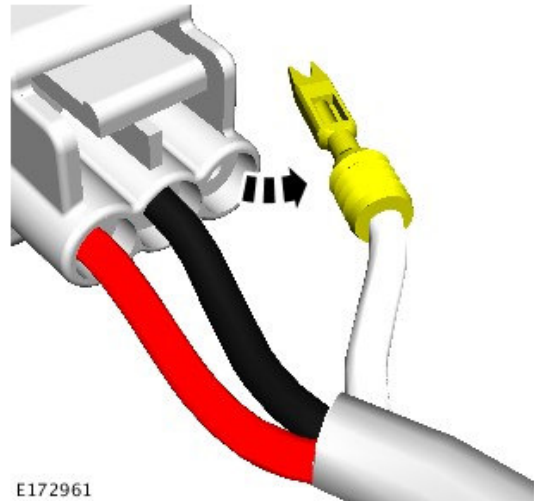

**11.** Remove the black wire electrical pin from the electrical connector.

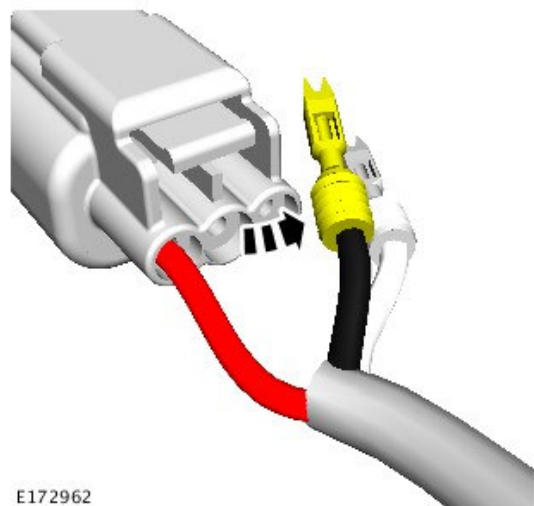

**12.** Install the white wire electrical pin into the center socket on the electrical connector.

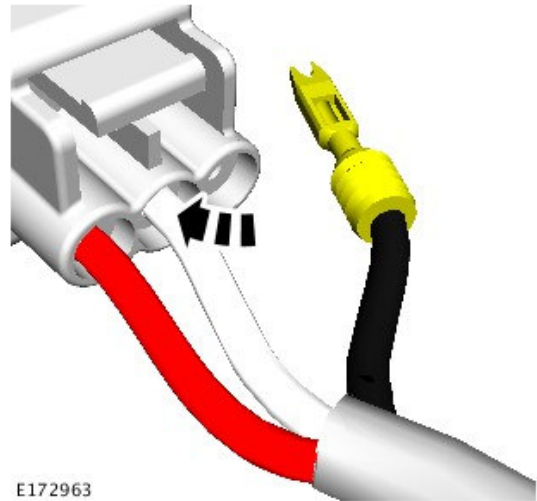

**13.** Install the black wire electrical pin into the right-hand-side socket on the electrical connector.

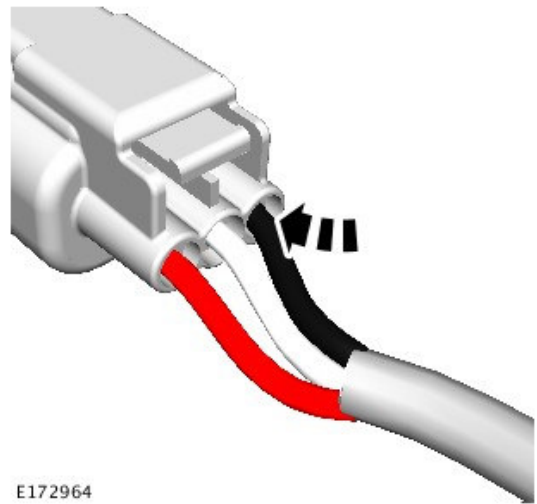

**14.** To install, reverse the removal procedure.