

# TECHNICAL BULLETIN

## Q322NAS2

### 27 FEB 2014



© Jaguar Land Rover North America, LLC

NOTE: The information in Technical Bulletins is intended for use by trained, professional Technicians with the knowledge, tools, and equipment required to do the job properly and safely. It informs these Technicians of conditions that may occur on some vehicles, or provides information that could assist in proper vehicle service. The procedures should not be performed by 'do-it-yourselfers'. If you are not a Retailer, do not assume that a condition described affects your vehicle. Contact an authorized Land Rover service facility to determine whether this bulletin applies to a specific vehicle.

Changes are highlighted in gray

### **SECTION: 204-05**

Service Action: Air Suspension Thermistor Wiring Short Circuit

### **AFFECTED VEHICLE RANGE:**

**Range Rover (LG)**

**Model Year:** 2013

**VIN:** DA100000-DA107500

### **MARKETS:**

NAS

### **CONDITION SUMMARY:**

**Situation:** An issue has been identified where the Air Suspension System may not respond when operating the air suspension switchpack and the message 'Air suspension inactive' may be displayed on the Instrument Cluster. Upon further investigation, Diagnostic Trouble Code (DTC) U210A-16 may also be stored.

**Action:** Retailers are required to **HOLD** all affected vehicles within the listed VIN range that are in their control and refrain from releasing the vehicles for new or used vehicle sale pending completion of the rework action detailed in this Technical Bulletin. Unsold vehicles must have this performed prior to vehicle handover to the customer. Affected vehicles already in the hands of customers should be updated at the same time as Service Action Q332.

### **PARTS:**

DESCRIPTION	PART No.	QTY.	EXPECTED % of VEHICLES REQUIRING PARTS*
Protective Sleeve	LR052962	1	100



**NOTE: \* when ordering parts, order only the expected percentage demand of parts identified**

### **SPECIAL TOOLS:**

Refer to Workshop Manual / Service Instruction for any required tools

### **WARRANTY:**



**NOTE: Check DDW to ensure that the vehicle is affected by this program prior to undertaking any rework action. Repair procedures are under constant review, and therefore times / prices are subject to change; those quoted here must be taken as guidance only. Refer to the Repair Times Searcher (RTS) on TOPIX to obtain the latest repair time. At the time of confirming a booking for vehicle repair, ensure that all outstanding Service Actions are identified to ensure the correct parts are available and adequate workshop time is allocated for repairs to be completed at one visit.**

Warranty claims must be submitted quoting Program Code '**Q322**' together with the relevant Option Code from the table. The SRO and part information listed have been included for information only. Drive in / drive out allowance may not be claimed as this work should be carried out in conjunction with Q332.

This program is valid for a limited time only. Warranty claims with a repair date prior to the **31 December 2015** closure date must be submitted for payment within 30 calendar days of completion of the repair.

PROGRAM CODE	OPTION CODE	DESCRIPTION	SRO	TIME (HOURS)	PARTS / SUNDRY CODE	QTY. / VALUE
Q322	B	Fit protective sleeve to suspension air supply unit harness	64.50.89.30	0.30	LR052962	1

 **NOTE: Normal Warranty policies and procedures apply**

### **SERVICE INSTRUCTION**

 **NOTE: There is no requirement to connect SDD to check for DTC U210A-16 as the code will automatically clear at the next ignition cycle when the concern is rectified.**

-  **WARNING: The spare wheel is heavy and if handled incorrectly may cause injury. Use extreme caution when lifting, lowering, and maneuvering the spare wheel.**

Remove the spare wheel and disconnect the battery ground cable (see TOPIX Workshop Manual, Section 414-01).

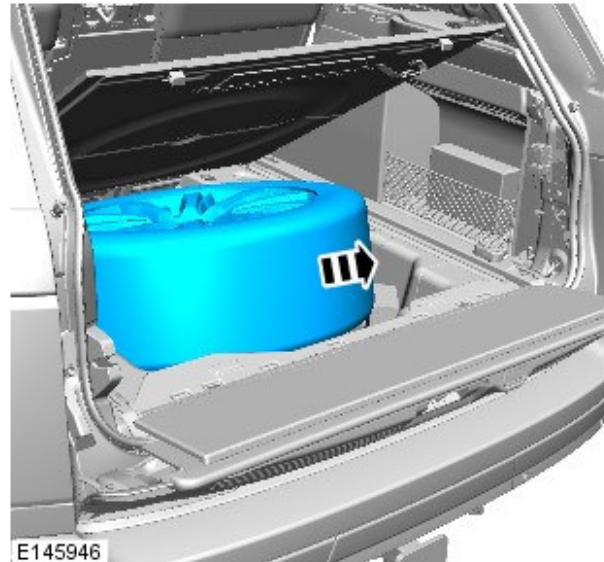

-  **NOTE: The air compressor unit is protected by an acoustic box which tilts to allow access to the vehicle battery.**

Remove the two bolts.

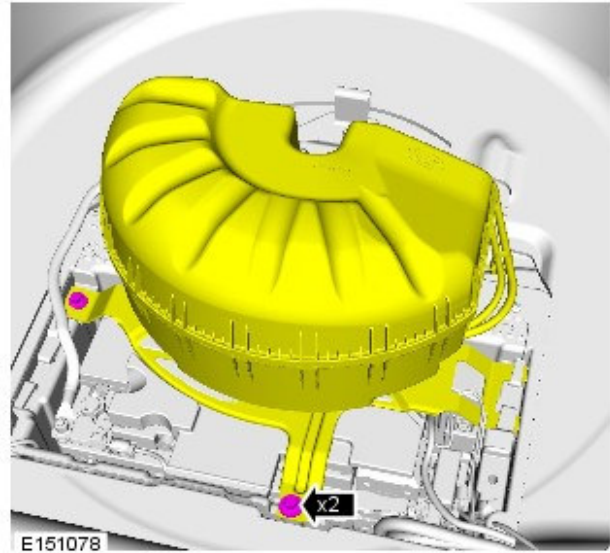

3.  **CAUTION: Retain the 19 metal clips.**

 **NOTE: Use a suitable tool (open-ended ring spanner) to remove / lever off the securing clips.**

Gain access to the air supply housing (two parts [upper and lower] which surrounds the suspension air supply unit).

- Separate the upper and lower parts of the air supply housing and remove the upper part.



4.  **NOTE: Do not completely remove the suspension air supply unit from the vehicle; the modification is carried out in the vehicle.**

Tilt the air supply housing to allow removal of the suspension air supply unit securing bolts.

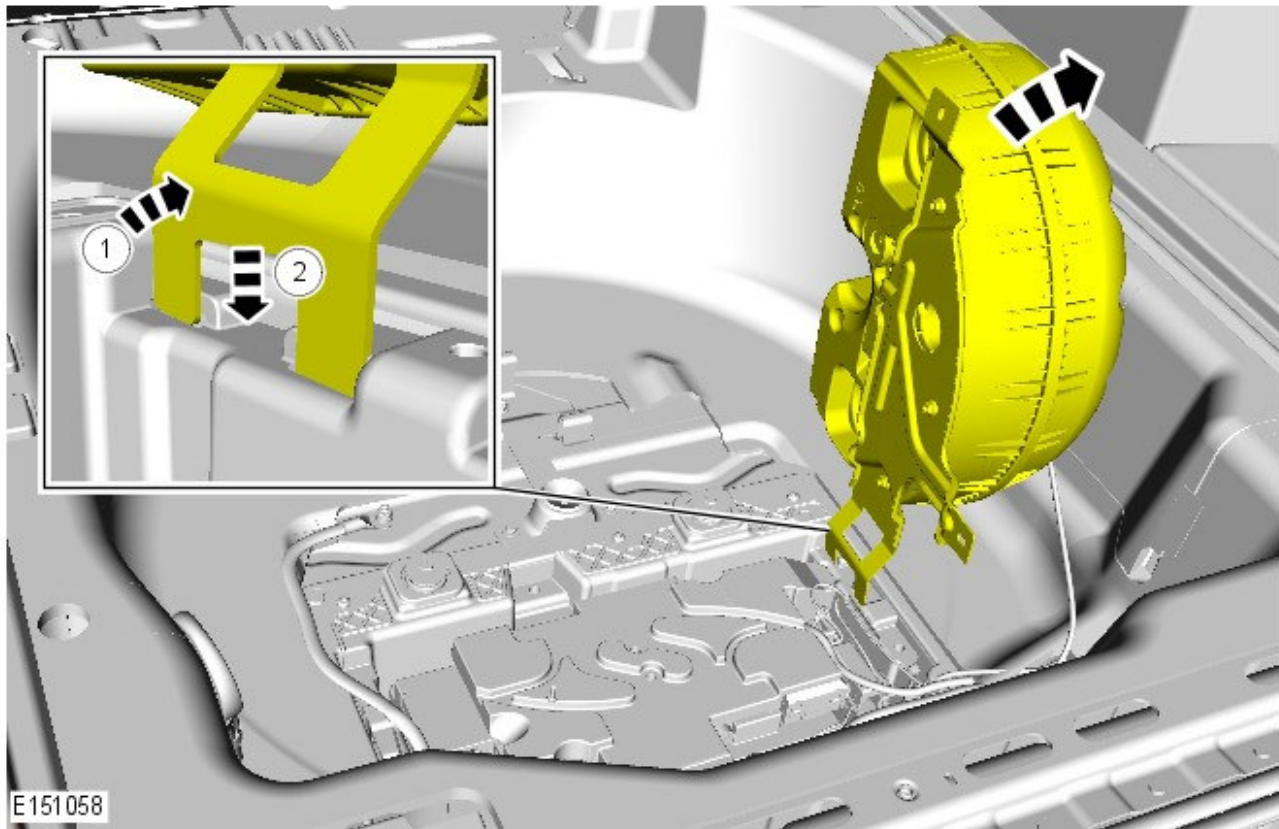

5.  **CAUTION: Pay attention to compressor mountings, washer, rubber cover, bolt, and spring.**

With the suspension air supply unit in the upright position, use a TX30 Torx tool to unscrew only two of the three suspension air supply unit fixing bolts.

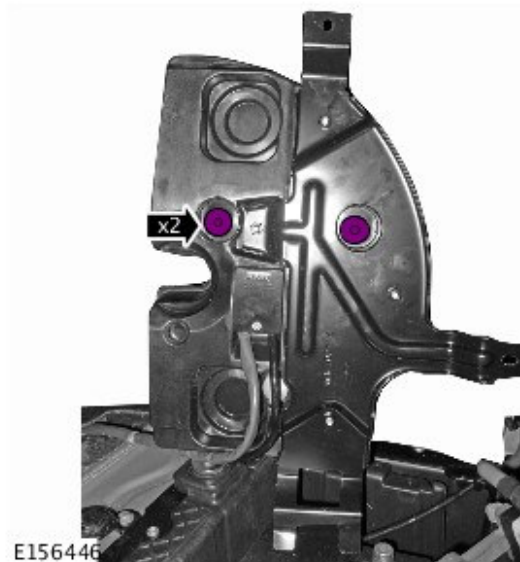

6.  **NOTE: Note damage or stripped cables**

**(replace suspension air supply unit if wires are damaged and copper is visible).**

Pull the suspension air supply unit from its fixed position and inspect the thermistor harness (cable).

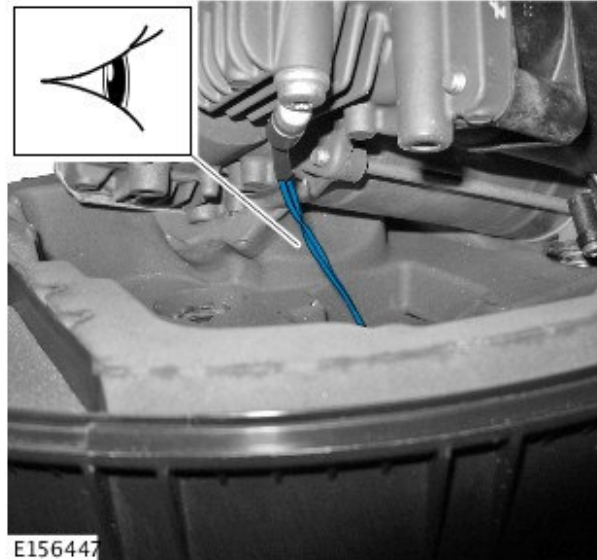

7.  **NOTE: The protective sleeving must be trimmed to a suitable length on a suitable surface prior to installation. Make sure the protective sleeve covers the entire length of the thermistor harness.**

Push the protective sleeving over the thermistor harness (cable).

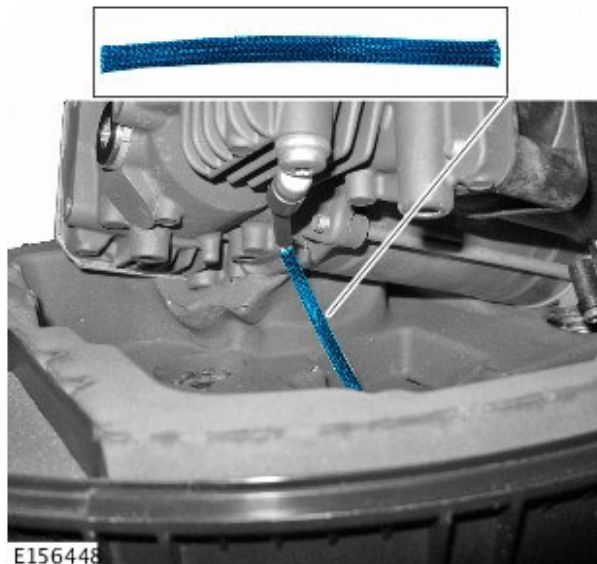

8.  **NOTE: Pay close attention to the washer and rubber insulator washer to make sure they are positioned correctly.**

Assemble the suspension air supply unit bolt from the rear and the spring to the bolt from inside the air supply housing, and then the rubber insulator and washer (metal) in the correct sequence.

- Push the suspension air supply unit carefully to the

- bolt.
- Screw on the bolt from the rear of the suspension air supply unit:
    - The first three turns by hand;
    - Hand tight using a TX30 Torx;
    - Torque to 10.5Nm +/- 1Nm.

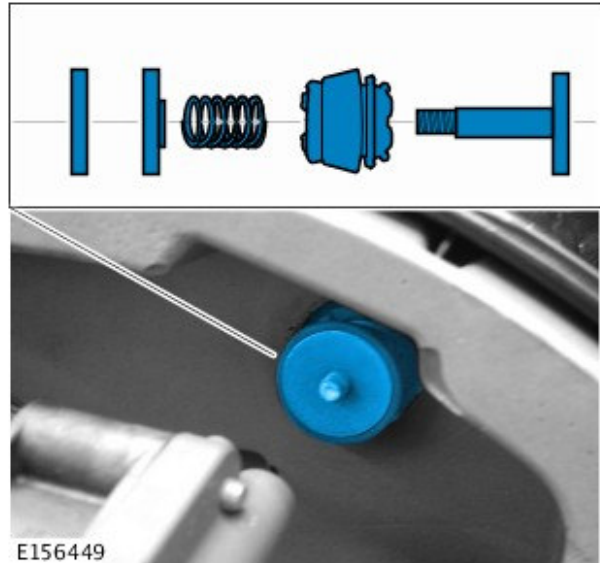

- 9.** Before replacing the air supply housing upper cover, make sure that the intake hose and filter are fitted in their correct positions.

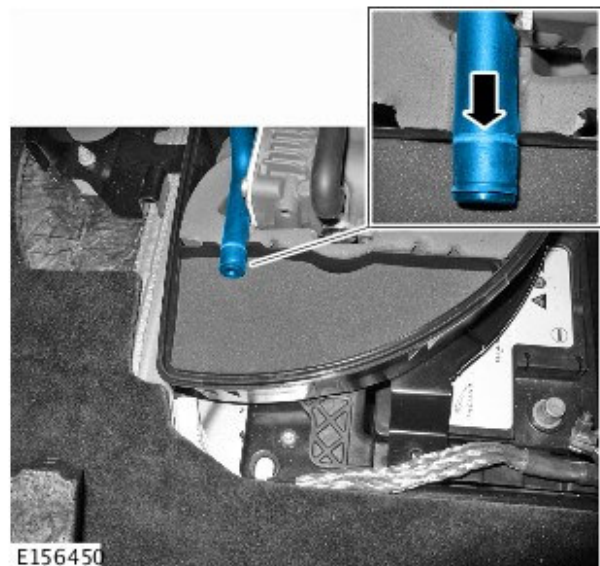

- 10.** Install the upper section of the air supply housing, making sure of the accuracy of the fit:
- Secure the two sections with the 19 metal clips.

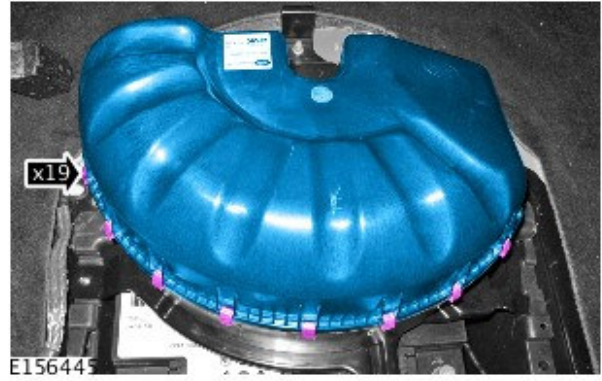

**11.** Install the two securing bolts (10Nm).

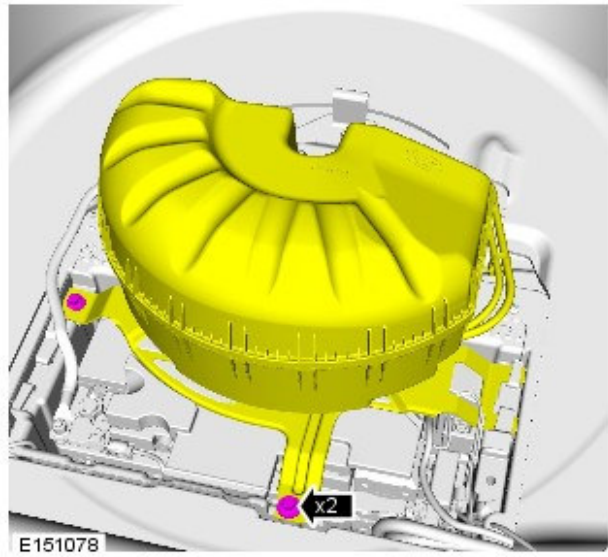

**12.** Connect the battery ground cable and install the spare wheel/tire assembly (see Topix Workshop Manual, Section 414-01).