

TECHNICAL BULLETIN
LTB00612NAS2
26 SEP 2014



© Jaguar Land Rover North America, LLC

NOTE: The information in Technical Bulletins is intended for use by trained, professional Technicians with the knowledge, tools, and equipment required to do the job properly and safely. It informs these Technicians of conditions that may occur on some vehicles, or provides information that could assist in proper vehicle service. The procedures should not be performed by 'do-it-yourselfers'. If you are not a Retailer, do not assume that a condition described affects your vehicle. Contact an authorized Land Rover service facility to determine whether this bulletin applies to a specific vehicle.

This reissue replaces all previous versions. Please destroy all previous versions.

Changes are highlighted in gray

SECTION: 501-10

'Creak' Noise From Front Seat Frame

AFFECTED VEHICLE RANGE:

Range Rover (LG)

Model Year: 2013-2014
VIN: DA001204-EA127500

MARKETS:

NAS

CONDITION SUMMARY:

Situation: A 'creak' noise from the base of the front seat may be evident.

Cause: This may be caused by insufficient lubricant during the assembly process.

Action: Should a customer express the concern, follow the Service Instruction outlined below

PARTS:



NOTE: Nyogel 774L grease to be sourced from the Squeaks & Rattles kit; refer to Technical Bulletin LTB00389NAS and Service Bulletin STE12-02 for more information and how to replenish the items in the Squeaks & Rattles Kit when necessary.

	Nyogel 774L	Quantity: As necessary
LR067775	Syringe	Quantity: 1

TOOLS:

No Tools Required

WARRANTY:



NOTE: Repair procedures are under constant review, and therefore times are subject to change; those quoted here must be taken as guidance only. Always refer to TOPIx to obtain the latest repair time.



NOTE: DDW requires the use of causal part numbers. Labor only claims must show the causal part number with a quantity of zero.

DESCRIPTION	SRO	TIME (HOURS)	CONDITION CODE	CAUSAL PART
Apply Nyogel 774L grease to seat frame	05.10.10	0.1	42	LR041773



NOTE: Normal Warranty procedures apply.

SERVICE INSTRUCTION:

Service Instruction changes are extensive and therefore not highlighted.

1. Adjust the affected front seat to the highest and most forward position.
2. Release the trim hooks from the bottom of the seat base.

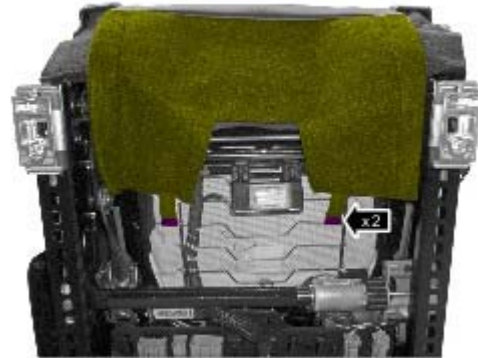

E143833

3.  **NOTE: Apply Nyogel 774L grease to both sides of the seat frame in the areas shown.**

Using the syringe and Nyogel 774L grease from the Squeaks & Rattles Kit, lubricate the seat base rear crossmember from the top to the bottom.

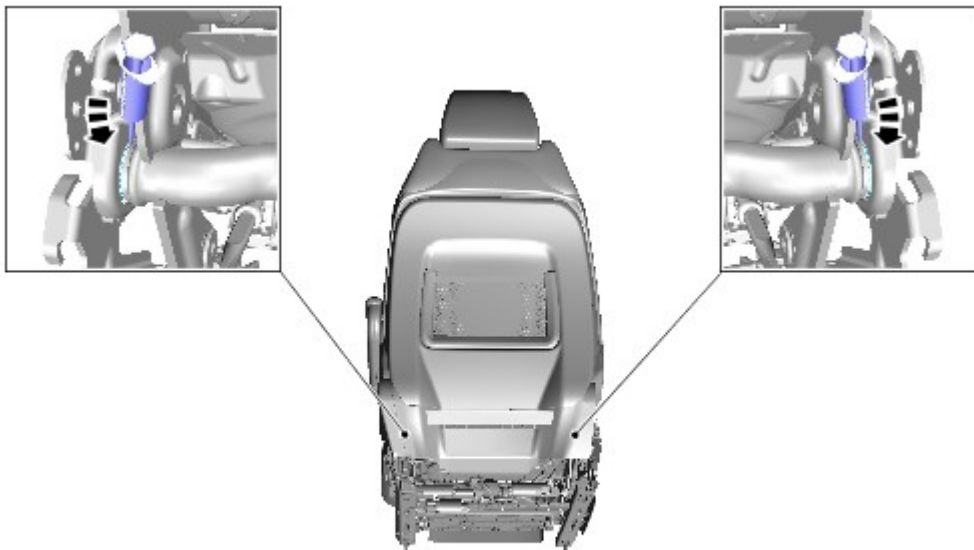

E166567

4. From the bottom position, apply lubricant from bottom to top position.

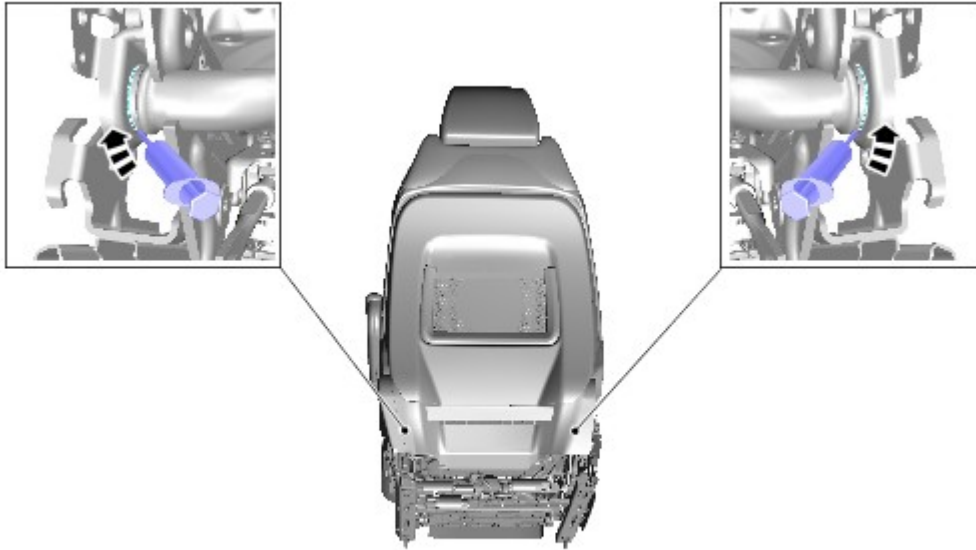

E166568

5. Sit on the seat and operate the height of seat from highest to lowest position, then return to the highest position.

- Repeat this step 10 times.

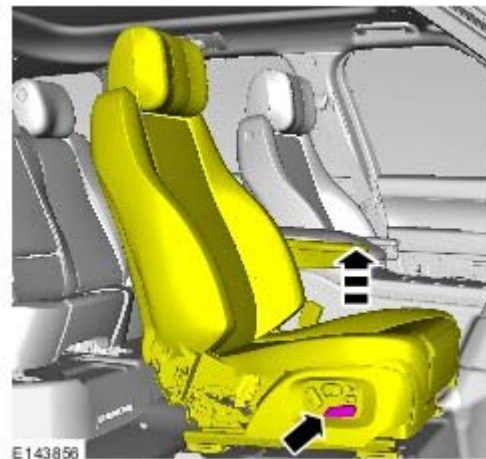

6. Install the trim hooks back to the bottom of the seat base.

7. Adjust the seat to the original position.