

TECHNICAL BULLETIN

LTB00575NAS3

09 SEP 2014



© Jaguar Land Rover North America, LLC

NOTE: The information in Technical Bulletins is intended for use by trained, professional Technicians with the knowledge, tools, and equipment required to do the job properly and safely. It informs these Technicians of conditions that may occur on some vehicles, or provides information that could assist in proper vehicle service. The procedures should not be performed by 'do-it-yourselfers'. If you are not a Retailer, do not assume that a condition described affects your vehicle. Contact an authorized Land Rover service facility to determine whether this bulletin applies to a specific vehicle.

This reissue replaces all previous versions. Please destroy all previous versions. Only refer to the electronic version of this Technical Bulletin in TOPIx.

Changes are highlighted in gray

SECTION: 418-00

Horn Link Lead

AFFECTED VEHICLE RANGE:

LR2 (LF)

Model Year:	2010-2013
VIN:	AH148520-DH382339

MARKETS:

NAS

CONDITION SUMMARY:

Situation: The horn may be inoperative.

Cause: This may be caused by loose horn link lead connector terminals.

Action: Should a customer express this concern, follow the Service Instruction outlined below.

PARTS:

LR040729	Horn assembly - 2011-2013MY	Quantity: 1
LR053186	Link lead - 2010-2013MY	Quantity: 1
LR059158	Horn assembly - 2010MY	Quantity: 1

TOOLS:

Refer to Workshop Manual for any required special tools.

WARRANTY:

NOTE: Repair procedures are under constant review, and therefore times are subject to change; those quoted here must be taken as guidance only. Always refer to TOPIx to obtain the latest repair time.

NOTE: DDW requires the use of causal part numbers. Labor only claims must show the causal part number with a quantity of zero.

DESCRIPTION	SRO	TIME (HOURS)	CONDITION CODE	CAUSAL PART
Horn - Renew	86.30.89.29	1.1	X2	LR053186

NOTE: Normal Warranty policies and procedures apply.

SERVICE INSTRUCTION:

1. Remove front bumper cover (see TOPIx Workshop Manual, Section 501-19: Bumpers).

2.  **NOTE: Bumper shown removed from vehicle for clarity.**

Disconnect the two horn connectors and loosen the wiring harness from its fixing points in the front bumper.

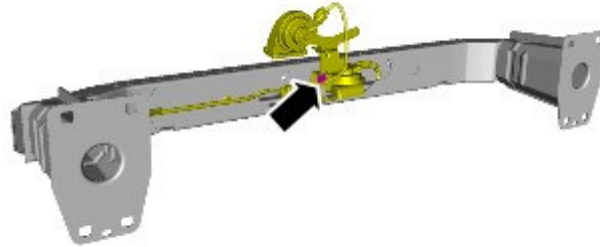

E131002

3.  **NOTE: Leave the horn assembly inside the bumper in place.**

Remove the top horn assembly from the central fixing point.

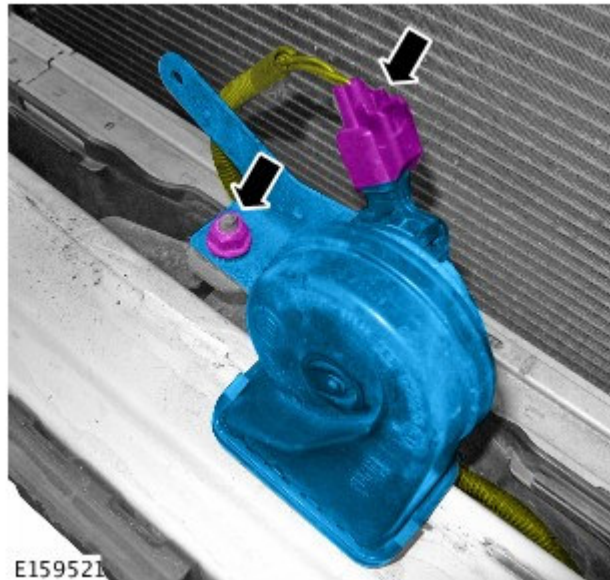

E159521

4. Remove the radiator shroud to allow access to the horn assembly and wiring harness (see TOPIX Workshop Manual, Section 501-19: Bumpers).

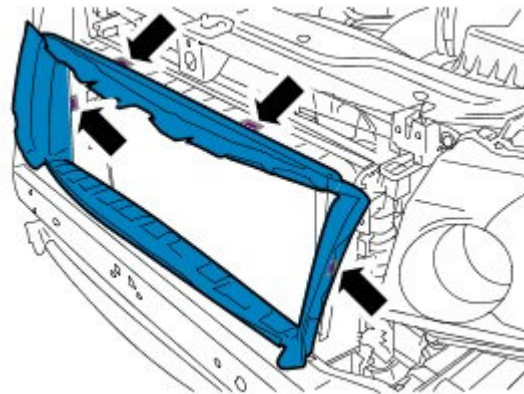

E73793

5.  **CAUTION: Color designation for original vehicle harness: 1 - Live/Positive = Violet/Green; 2 - Earth/Ground = Yellow/Black.**

 **NOTE: Identify the correct wiring designations (see TOPIX Workshop Manual,**

**Electrical Wiring Diagram, Section 413-06:
Horn).**

 **NOTE: Replacement link lead wiring is not color coded; make sure connections are made to correct polarity.**

Place the new horn link lead next to the existing wiring harness; identify a suitable position to connect the new horn link lead to the existing wiring harness.

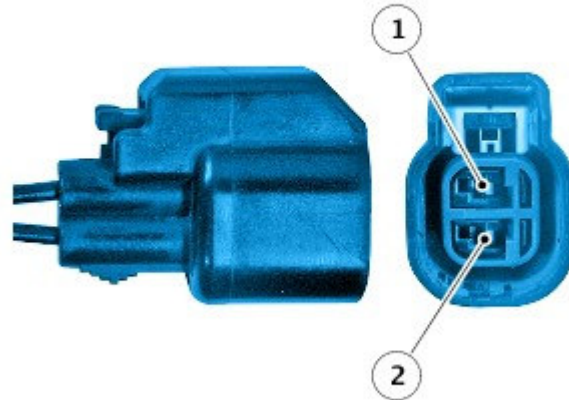

E159524

6.  **NOTE: For additional information, see TOPIx Workshop Manual, Section 418-02: Wiring Harnesses Description and Operation.**

Using suitable wiring connections connect new horn link lead.

7. Install the radiator shroud (see TOPIx Workshop Manual, Section 501-19: Bumpers).

8. Install the horn assembly and secure to the original central bracket:

- Tighten to 10Nm.

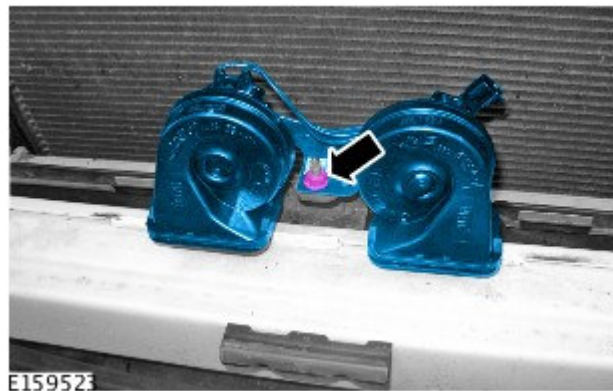

E159523

9. Install the radiator shroud and front bumper cover (see TOPIx Workshop Manual, Section 501-19: Bumpers).