

2600 AMERICAN DRIVE  
POST OFFICE BOX 2017  
APPLETON, WISCONSIN 54912-2017  
920-832-3000 • FAX 920-832-3208  
www.piercemfg.com



**August 15, 2014**

**Pierce Dealer**

**Field Update Notice # 74B253  
Hercules CAFS Hydraulic Hose**

Pierce has determined some vehicles built with the Hercules CAFS may have had an incorrect hydraulic hose installed.

Issue:

Vehicles may have shipped with a hose rated less than 2000 psi in a location which should have a 5000 psi rated hose. The hose could burst, causing hydraulic fluid to be expelled under high pressure. Units affected by this campaign were built at the Pierce Mfg Florida Division between April 2013 and July 2014.

- Dealer is to inspect the hose from the pump to the motor to determine whether the correct PSI rated hose is installed (see attached diagram)
- If the hose is incorrect, the dealer will measure the hose and email length to [campaigns@piercemfg.com](mailto:campaigns@piercemfg.com)
- Pierce will supply a new hydraulic hose for dealer to install
- Pierce will pay 0.5 hour to inspect and measure hose
- Pierce will pay 1.5 hours to replace hose if needed
- Pierce will pay 2.0 hours travel if replacement is not required, 4.0 hours if replacement is required

Dealers will submit one warranty claim to Pierce once inspection and replacement (if required) is completed.

A list of trucks in your area can be found at [www.pierceparts.com](http://www.pierceparts.com). If you have any questions or concerns about this remedy, contact Pierce Customer Service at 1-888-974-3723.

Jim Carney  
Pierce Campaign Coordinator  
Phone: 888-974-3723  
Fax: 920-832-3260  
Email: [jcarney@piercemfg.com](mailto:jcarney@piercemfg.com)

**This hydraulic hose should be a minimum of 5000 psi.**

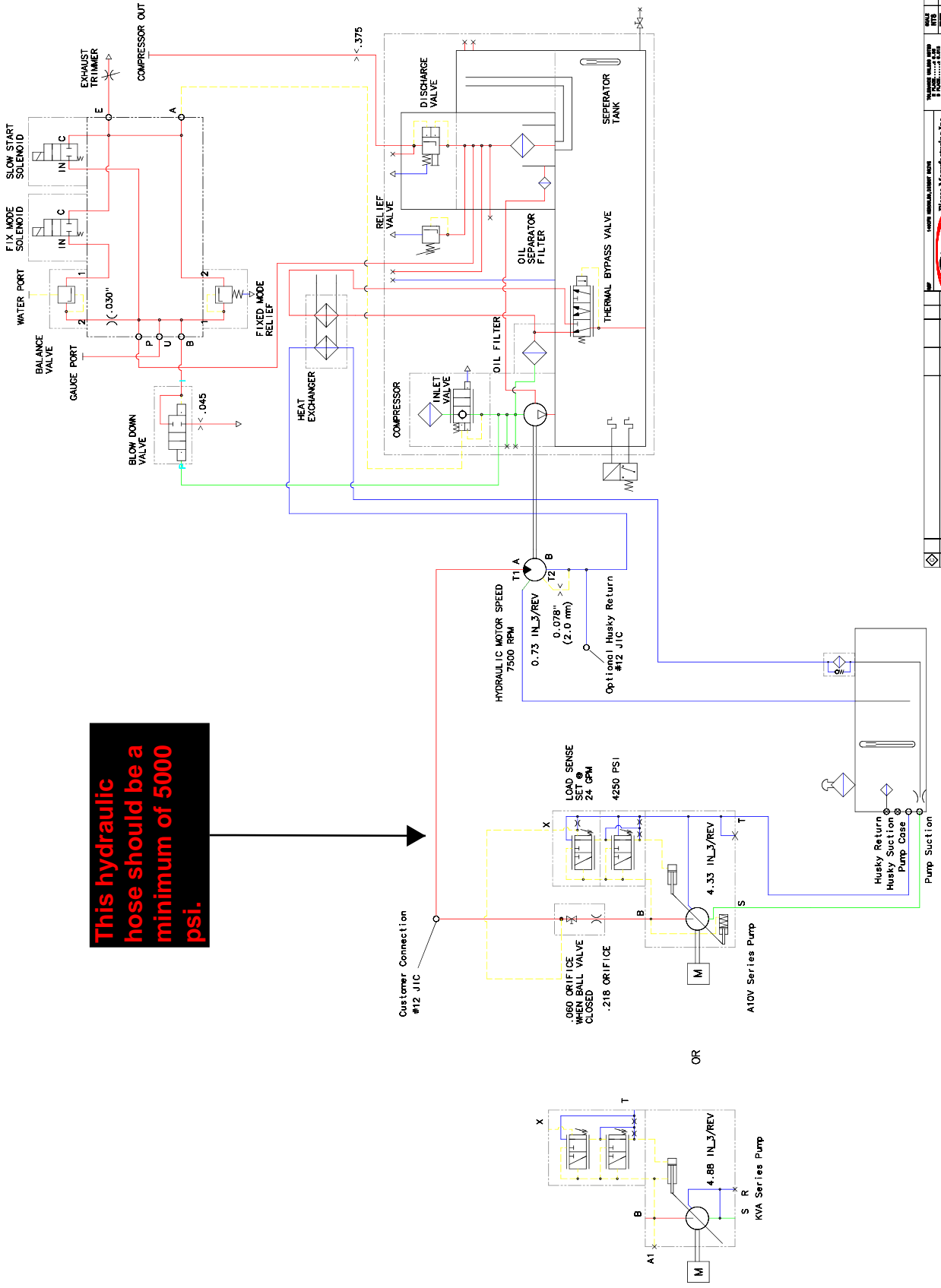

REV	DATE	DESCRIPTION	BY	CHK
1				
2				
3				
4				
5				
6				

	<b>Pirco Manufacturing Inc.</b> 10000 15th Street Dallas, TX 75244 (972) 241-1111 FAX (972) 241-1112 WWW.PIRCO.COM
<b>SCHEMATIC, CAPS, HYDRAULIC</b> 1877949	PART NO. DATE REV. QUANTITY UNIT DRAWN BY CHECKED BY APPROVED BY DATE