

L83X-
A.05.14+
L83X-
A.05.14

To: Official After Sales Network
Subject: Belt tensioner upgrade.
Date: 20th/06/2014
Pages: 15



Subject

Belt tensioner upgrade.

Model

All Lamborghini Model Aventador Coupè and Roadster MY 12,13,14 from VIN CLA00091 To VIN ELA02817.

Warning: some vehicles included in this VIN range may not be involved, so check carefully on the Lamborghini WEB Portal (at the section named VIN Info) if the cars in your workshop or in your dealer stock are involved before performing any other operation.

Information to the field

As a result of continuous product monitoring, Automobili Lamborghini Spa has found that on some vehicles the belt tensioner may become noisy.

Field solution

Replace belt tensioner with a new type.

P/N	Description	Q
0R8340118	Belt tensioner Kit:	1
	- Belt tensioner	(1)
	- hose seal ring	(2)
	- A/C seal ring	(2)
	- A/C seal ring	(2)
	- cable tie	(6)
	- M8x25 screw (thread locker)	(4)
	- M8x22 flanged screw (thread locker)	(2)

Replaced spare parts management.

Store replaced parts properly, and tagged them with bar code for their identification during Area Manager visits.

Warranty Claim data

The warranty reimbursement request for this rework action will be managed by the following standard Warranty Claim procedures.

A. Aventador MY 2012

Campaign Code: L83X-A.05.14
Campaign Des.: Belt tensioner upgrade
Cost code: 50
Component code: CCA0514
Trouble code: 220
Labor code: CCA0514100
Labor Time: 5,0 h

B. Aventador MY 2013 and beyond:

Campaign Code: L83X-A.06.14
Campaign Des.: Belt tensioner upgrade
Cost code: 50
Component code: CCA0614
Trouble code: 220
Labor code: CCA0614100
Labor Time: 5,2 h

Remember to fill all data in the section “Service and Recall Campaign” in the Warranty booklet of the vehicle as shown below.



Necessary materials

- Aventador MY 2013 and followers:
Super-capacitor Charge and Discharge
tool (p/n. 69195291)



- Wheel centering tool (p/n. 65395009)
- Blue thread locker agent (medium strength).



- Air-conditioning oil as Denso ND8 (quantity 0,15 l per vehicles) or similar.

Repair instruction:

Old tensioner.



New item.



On old component is present a notch which is absent on the new one.

It is possible to notice whether vehicle fits a new or old version of tensioner through a visual inspection.

From the inspection window on the auxiliary mountain you can check for the tensioner notch presence.



WARNING.



Operations to be performed at cold engine!

1. Secure vehicle to the lift appropriately before jacking in order to work safe from risks.
2. Disassembly of trunk closing frame.



Remove 6 screws that fix front hood cover and then the cover itself.

Screw tightening.
Torque: **2.5 Nm.**



Remove trunk to get access to battery.



3. Trunk disassembly.

Unscrews 4 screws. .

Screw tightening.
Torque: **8 Nm.**

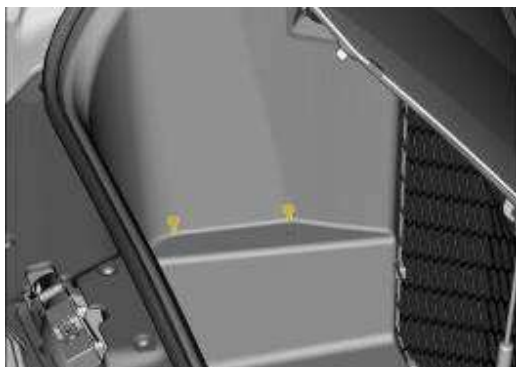

Lift trunk and disconnect plug from the 12V socket.

4. Battery disconnection procedure

Disconnect the positive fastener onto battery following the instructions reported in work shop manual Aventador MY 2012 (chapter **09 electrical system** □ **15 Battery** □ **Battery** □ **Disassembly/Assembly**)

a. Aventador MY2013 and 2014:

WARNING: open driver's door before disconnecting battery.

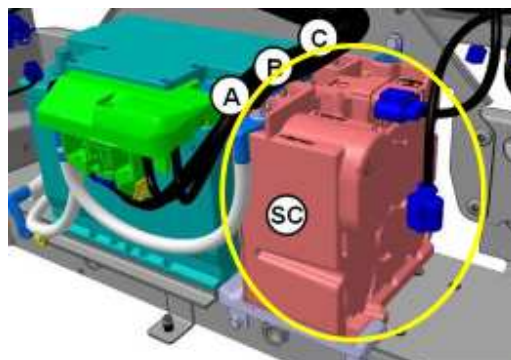



WARNING: Super-capacitor on board

Super-capacitor module supply energy necessary for engine start up while battery feeds the rest of electronic/electrical platform.

The device presents a high electrical charge.



RISK OF ELECTROCUTION

Before disconnecting battery positive pole it is mandatory to discharge the Super-Capacitor with the specific tool (p/n 69195291).

Work scrupulously as in Aventador2013 workshop manual (Chapter 09 Electrical system → 15 Battery → Battery → Description → Procedure for Super-Capacitor Draining).

Once Super-Cap discharge procedure is completed, control that the tool displays a voltage under 0,5 V

5. Remove trunk pool to get access to battery.
6. Unscrew fastener bolt onto positive pole

Torque: **6 Nm**

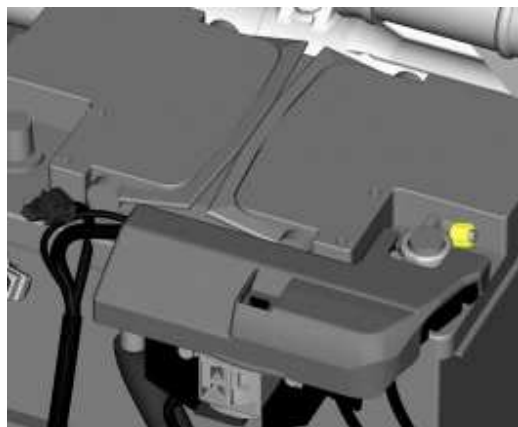

7. Loose positive pole terminal on battery.

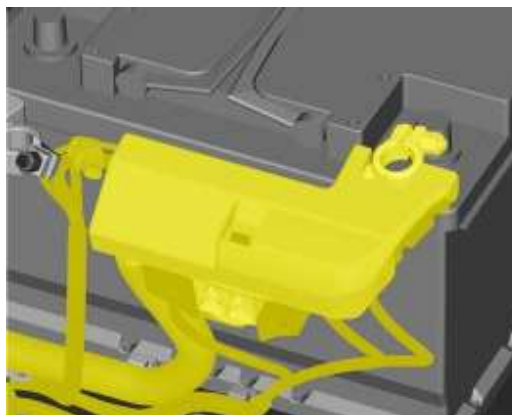

8. A/C system discharge.

- Connect hoses of A/C charging station to vehicle through HP and LP quick connectors.
- Operate phase of refrigerant fluid savage.



9. Disassembly of engine bay rear esthetical panel.

Remove 10 screws and 2 buffers that hold panel and then take it off.

Screw tightening.
Torque: **6 Nm.**

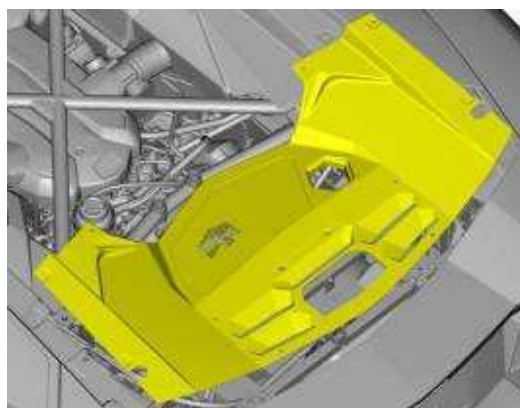

10. Disassembly of engine bay front esthetical panel.

remove 4 screws and then the front panel.

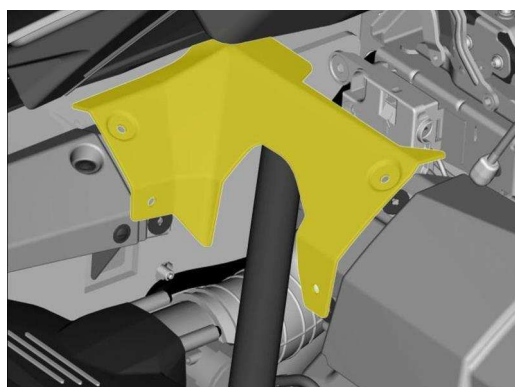

11. Disassembly of right esthetical panel.

Remove 2 screws and then take the panel off.

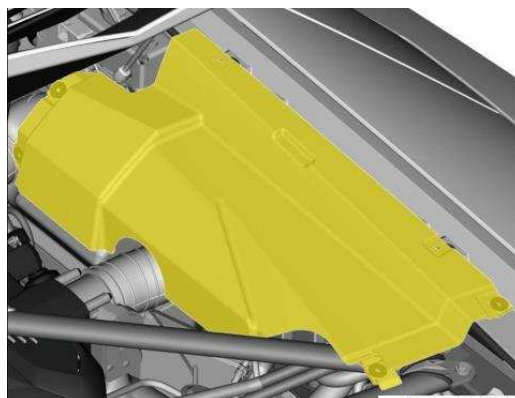

12. Disassembly of engine bay left esthetical panel.

Remove 5 screws that hold the panel and then take it off.



13. Rear tire disassembly.



Remark.

In order to avoid rims and brake discs damages use centering tool (p/n. 65395009) as shown in picture. This operation must be performed on both vehicle sides.

Wheel bolt tightening.
Torque: **160 Nm.**



14. Wheelhouse disassembly.



Each wheelhouse panel consist of 2 sections front and rear. It is recommended to disassemble both elements.

Screw tightening.

Torque: **9Nm M6 screws,
5Nm others.**



Remark.

Operation to be performed on both sides.

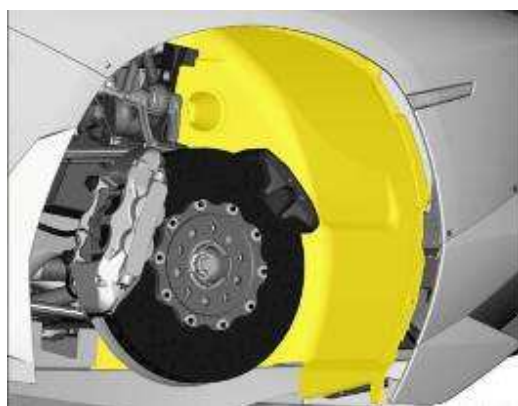

15. Central flat bottom disassembly.

Unscrew 16 screws so remove the central panel section.

Tightening screw.

Torque: **9 Nm.**

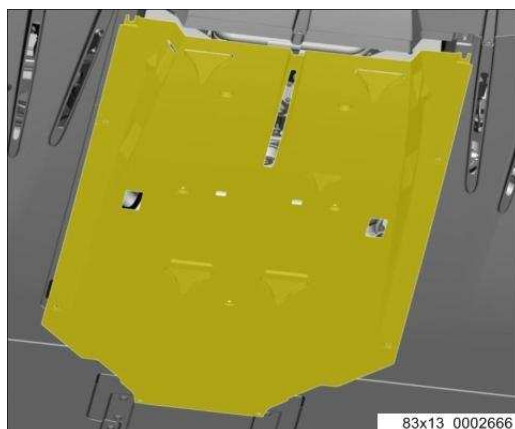

83x13_0002666

16. Release sway bar connecting rod.

Unscrew upper nut of rod which connect sway bar to upper suspension arm freeing it from the bar itself.



Remark.

Operation to be performed on both sides.

Nut tightening.

Torque: **65Nm.**



17. Engine cross member disassembly.

Remove bolts then take cross member off.



Remark.

bolts must be replaced after every disassembly.

Bolt tightening.

Torque: **27 Nm ± 10% M8.**

40 Nm M10.

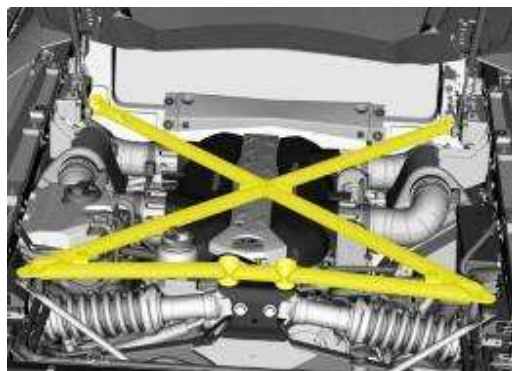

18. Disassembly of rear chassis tie rod.

unscrew fixing elements and then remove tie rod. Keep well distinguished right tie rod from the left.

Screw tightening.
Torque: **25Nm.**



Remark.

During assembly respect the arrow that signs upper side.

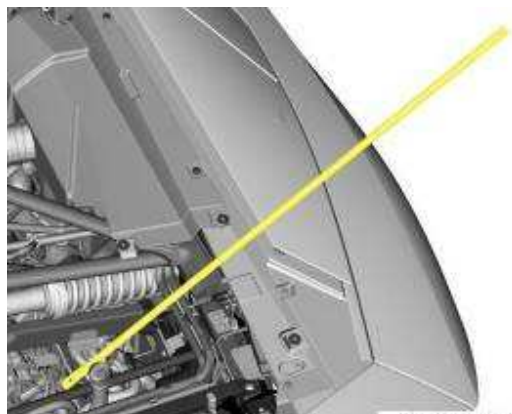

19. Rear shock absorber disassembly



Remark.

Procedure to be performed on both sides.

Unscrew nut and remove screw from rear suspension rocker.

Screw tightening.
Torque: **110Nm**

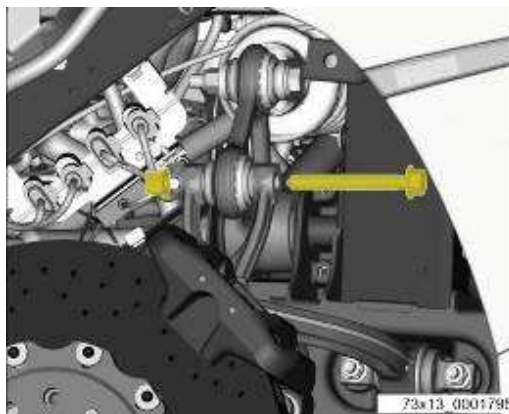

Unscrew nut and remove bolt that secure shock absorber.

Bolt tightening.
torque: **110Nm.**

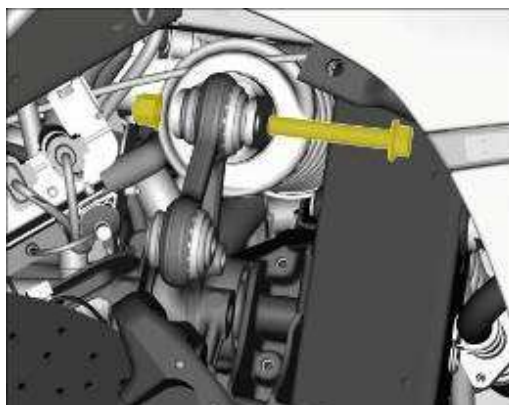

Rotate rocker downward.

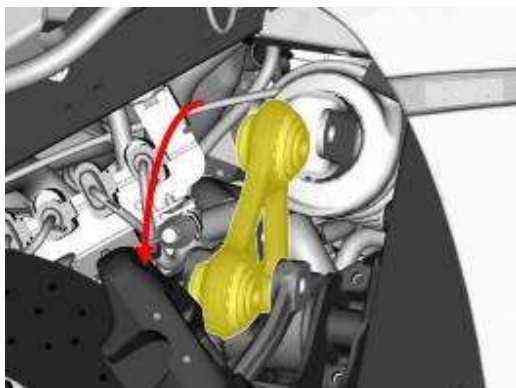

Unscrew nut and pull bolt out that fix shock absorber.

Bolt tightening.
torque: **110Nm**

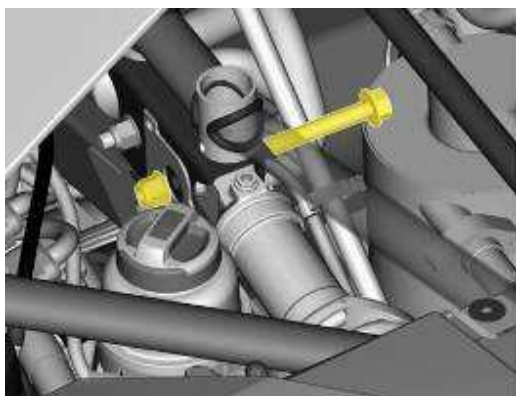

Remove shock absorber. Keep right and left wheel distinguished and during reassembly fit them with logo OHLINS pointing upward.

20. Disassembly of shock absorber mounting crossbar.

Remove screws that fix brackets of power steering oil tank and refrigerant hoses, then release brackets from crossbar.

Screw tightening.
Torque: **10Nm M6**
8Nm M8

Remove 8 screws that fix crosspiece to chassis.



21. Disassembly of power steering pump.

Use special tool (p/n. 61895067) to loosen auxiliary belt.



Remark.

Be extremely careful to avoid pulley damages.

Lock pulley by inserting an Allen key into shaft.

Unscrew three screws and remove pulley.

Screw tightening.
Torque: **28 Nm**



Remark.

During reassembly respect the writing "FRONT" which marks pulley external side.

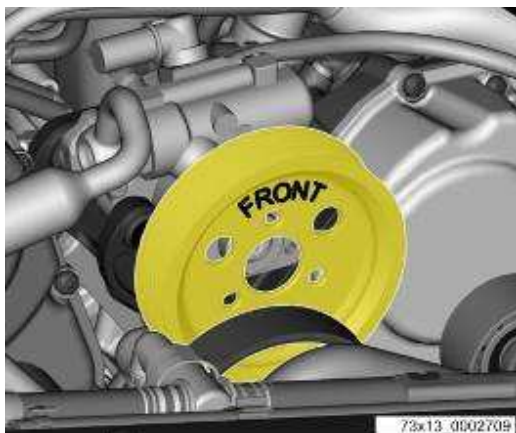

22. Disassembly of oil return hose.

Prepare a container to collect fluids.

Unscrew hose fixing elements.



Remark.

It is mandatory replace hose seal rings with those supplied in Kit

Hose tightening.

Torque: **10Nm**

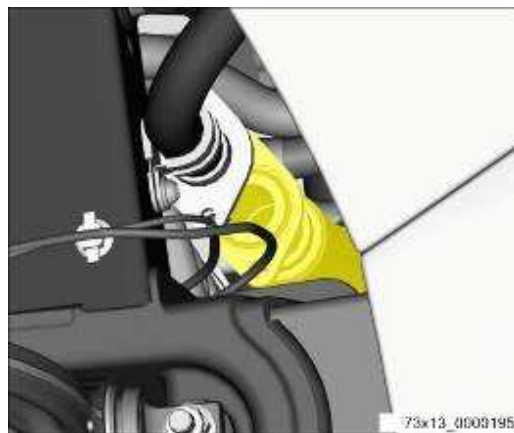
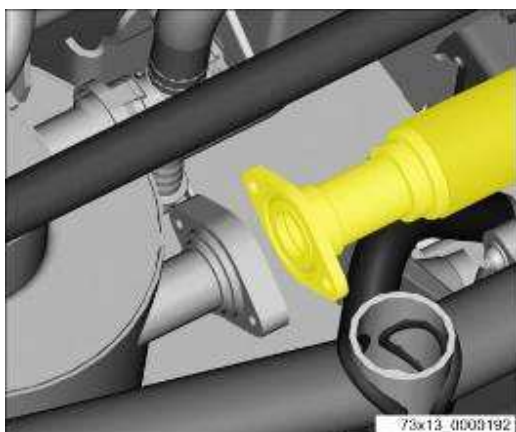

23. Lifting bracket removal.

Release wiring from auxiliary mounting.

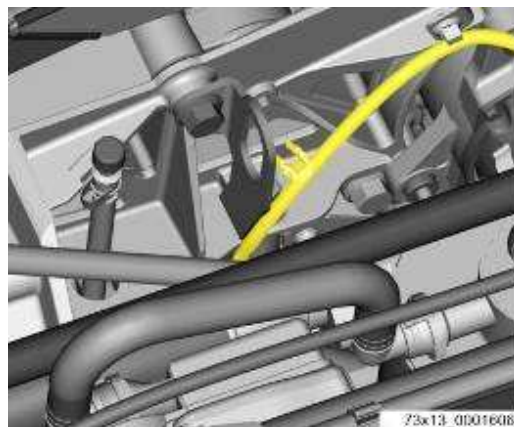

Remove screw of lifting bracket.

Screw tightening.
torque: **70Nm.**

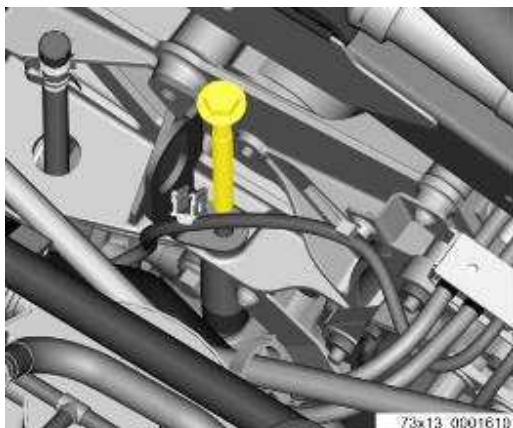

Remove second screw.



Remark.

Handle with care in order to not let drop and lose auxiliary bracket spacer during screw removal.

Screw tightening.
torque:: **45Nm.**

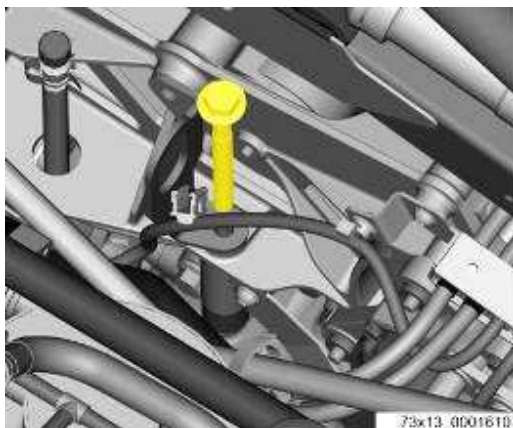

Remove lifting bracket..

24. Auxiliary mounting disassembly.

Remove fixing screw and so free hoses of compressor lines.

Screw tightening.
torque: **28Nm.**

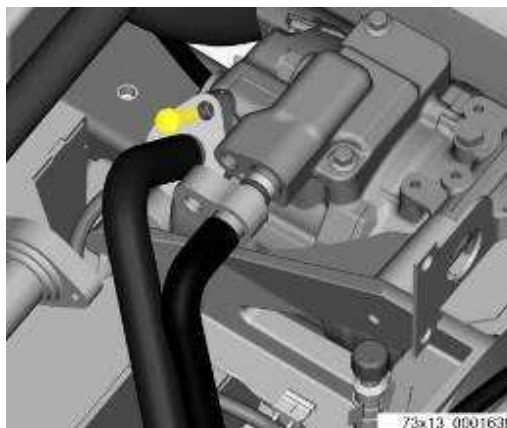

Unscrew fixing element of refrigerant lower hose.

Screw tightening.
Torque: **28Nm.**

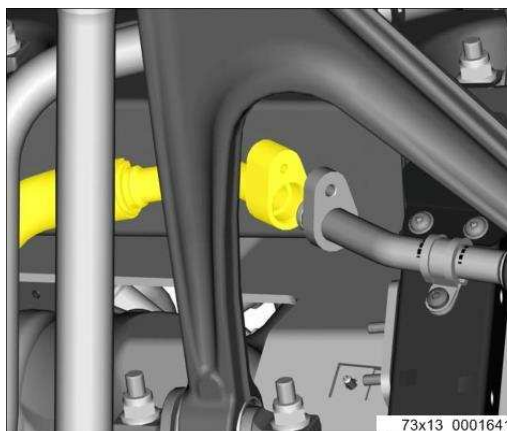

Remark.

It is necessary to replace seal rings with those included in spare part kit .

Free wiring from auxiliary assembly.

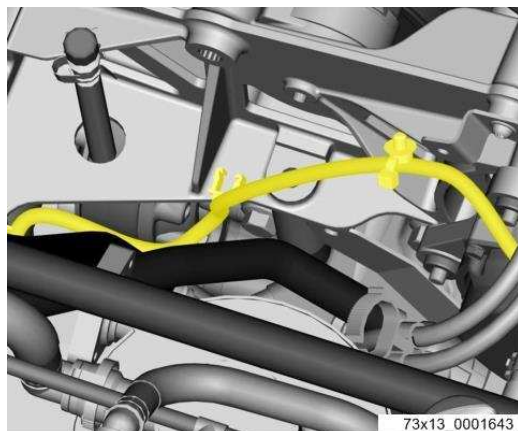

Remove screw, then free fuel cooler bracket of auxiliary mounting.

Screw tightening.
Torque: **10Nm.**

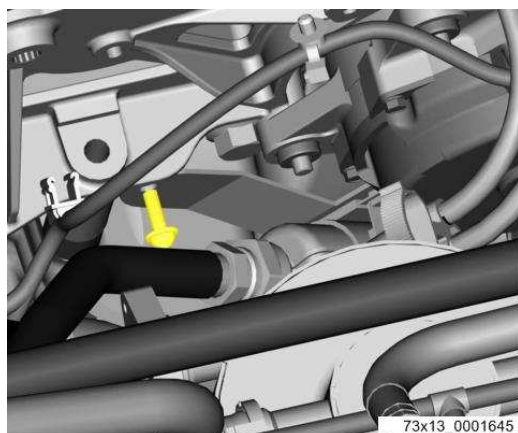

Open clamp that holds fuel lines.



WARNING

Pay attention to not bend or pinch fuel lines.

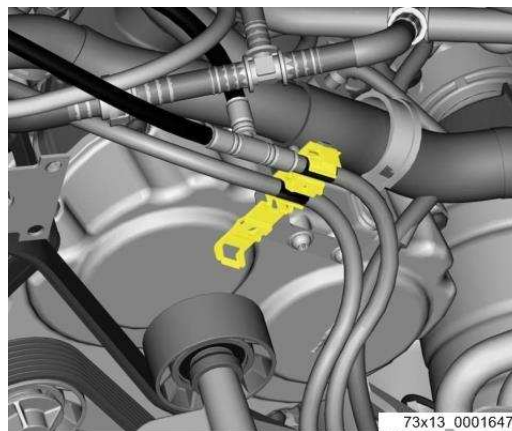

Remove screw which fix fuel line bracket so free auxiliary mounting bracket.

Screw tightening.
Torque: **10Nm.**

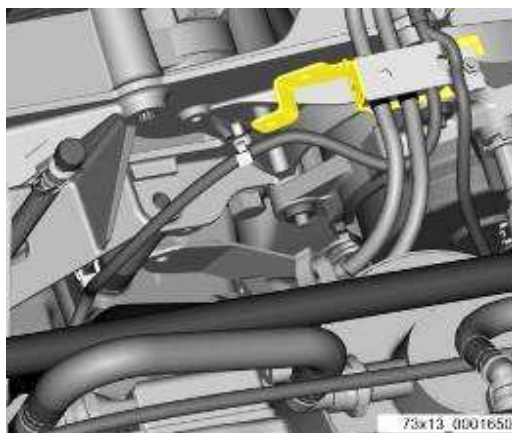

Loosen 2 screws that secure auxiliary mounting.

Screw tightening.
Torque: **70Nm.**



Free rear differential breather pipe and from clip and pull it out from hole onto aux. mounting.

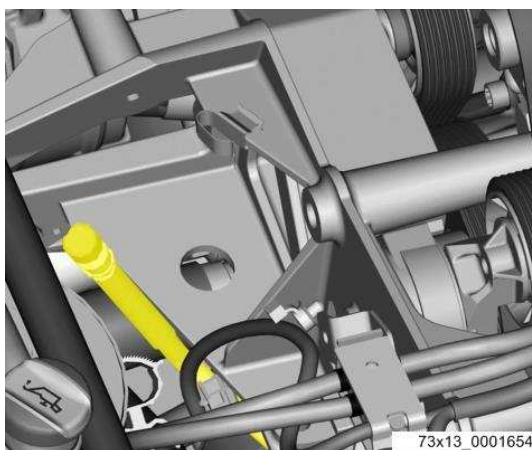

Open clamp that hold cooling lines.

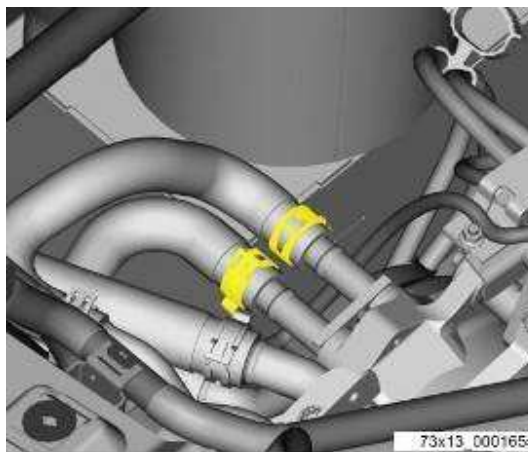

Arrange a container to collect fluid.

Apply hose pinch-off pliers to avoid coolant pouring out while removing alternator from auxiliary assembly.



After having clogged lines detach alternator.

Unscrew nut that fix alternator wiring after having pulled nut hood out, then remove wiring.

Nut tightening.
Torque: **20Nm**.



Remark.

During reassembly before fitting nut hood apply protective wax for electrical terminal or similar product onto alternator cable nut.

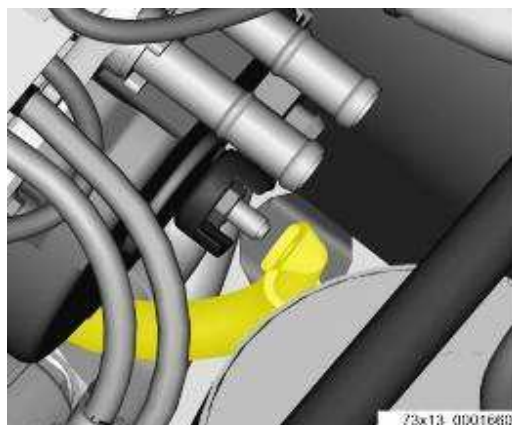

Disconnect terminal from alternator.

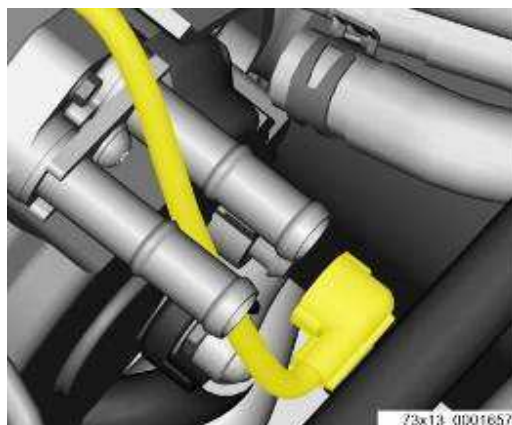

Remove screw that secure alternator firewall

Free firewall alternator from aux. mounting by unscrewing fixing element.

Screw tightening .
torque: **6Nm**.

Disconnect plug of A/C compressor.

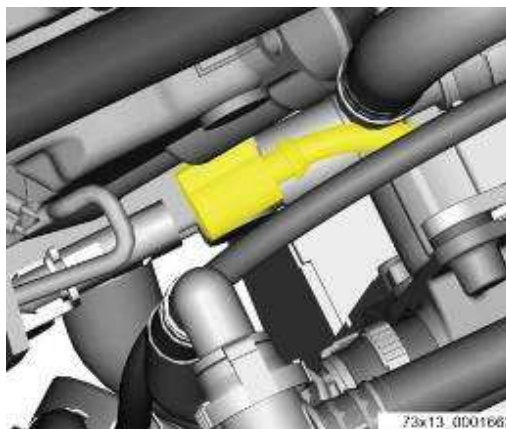

Disconnect connector of engine mounting and oil tank sensor.

Release wiring from mounting and shift it so that does not interfere when pulling auxiliary mounting out.

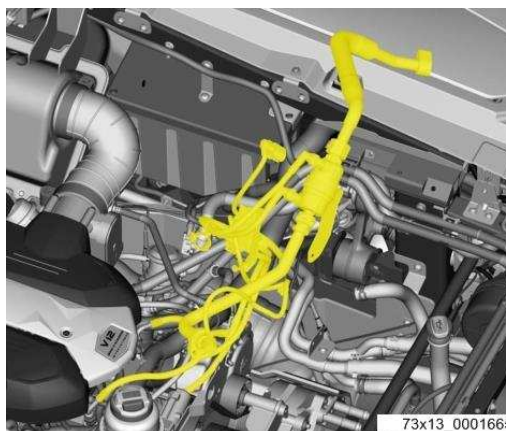

Pull out auxiliary mounting together with:

- compressor panel;
- compressor;
- compressor spacer;
- compressor pulley gear;
- pulleys;
- Belt tensioner with two fixing elements.

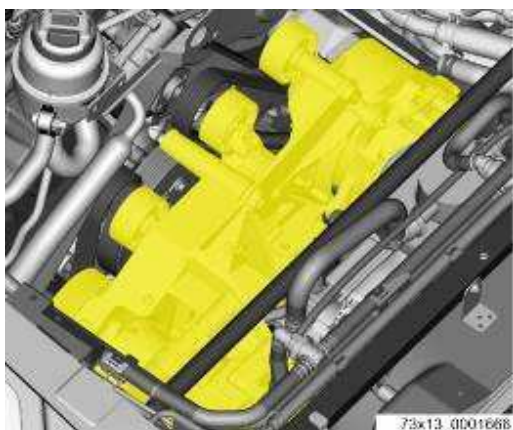

Pull two screws out from auxiliary support.



Remark.

Screws has to be put in place before reassembling aux. mounting.

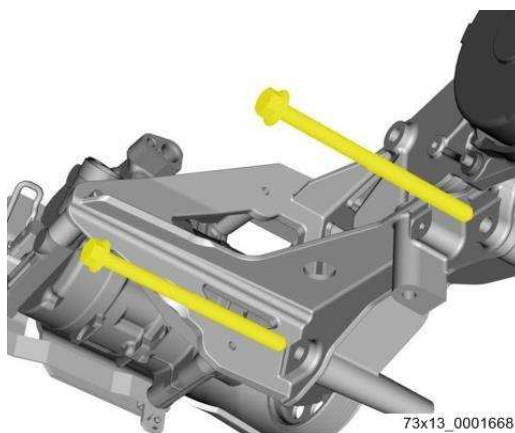

Remove spacer of aux. mounting.



Remark.

Spacer have to be put in place before reassembling aux. mounting.

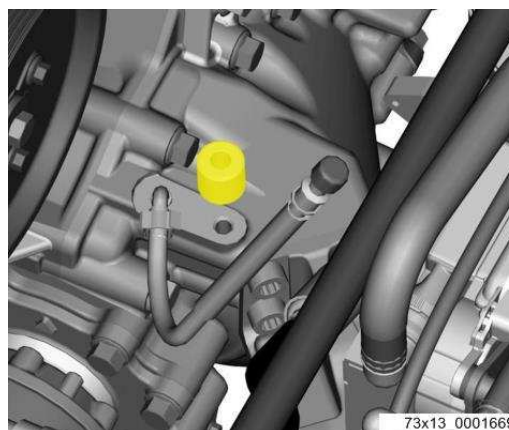

Remove auxiliary belt.



Remark.

Belt must be correctly installed and correctly reeled on engine pulley before reassembling auxiliary mounting as shown.





Remark.

During reassembling make belt pass between pulley and fixing pin as shown below.



Remark.

Before belt tensioning, check that belt fits correctly on pulleys of alternator engine, compressor, and power steering.

25. Tensioner disassembly.

Remove fixing screw and then tensioner .

Replace tensioner and screw with the ones supplied adding medium strength thread lockers (blue colored) on screw thread.

Screw tightening.

Torque: **28Nm + medium thread locker (blue colored).**