



## Roadster 2013 ST Upper Belt Guard Falling Off

[Printable Version](#)

---

**Summary:**

BRP has received reports concerning 2013 ST model upper belt guards falling off. This only affects 2013 models.

**Type:**

General

---

**TST Detail:**

The problem has been identified as being the Torx screws being too short and not reaching the nylon of the nut. At the present time the MY13 parts catalog does not show the correct Torx screw, this will be corrected.

Here is a breakdown of the parts needed:

A. 705007213 upper belt guard

B. ~~250000349 Torx Screw M6x10~~ --> 250000454 Torx Screw M6x12 (X2)

C. 232361600 Nut M6 (X2)

If the belt guard has fallen off and needs to be replaced, order all parts above.

If you want to be proactive and replace the screws, order the correct screws since the nut's nylon has not been touched.

Refer to [Warranty Bulletin 2013-9](#) for claiming details if the upper belt guard has not fallen off. If the upper belt guard has fallen off, the guard and nuts need to be claimed under regular warranty.

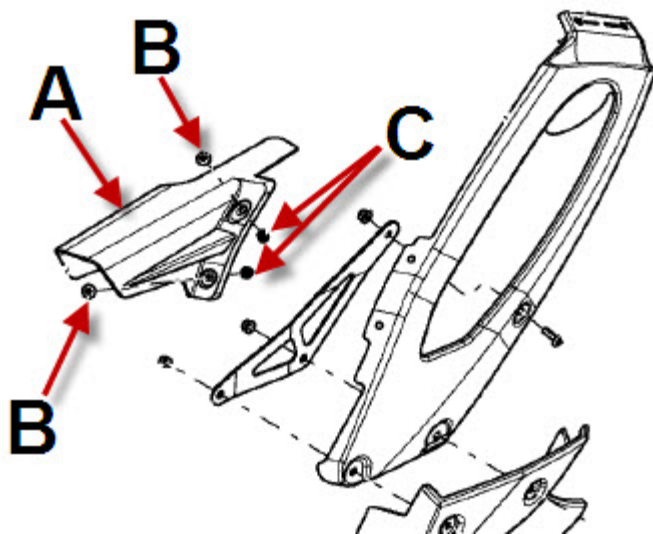

---

**Attachment:**

**First Published By:** Dany Davey on 2013-11-08

**Last Modified By:** Dany Davey on 2014-01-30