

TECH TIP

08MY-15MY Conventional Truck – Electric Trailer Brake Controller Application

OVERVIEW

The following information applies to the installation of a customer supplied and commercially available electric trailer brake controller for all 2008MY-2015MY Hino trucks. This application only applies to brake controllers which operate using a 12-volt input signal from the chassis when the brakes are applied.

SUBJECT VEHICLES

08MY-15MY Hino Conventional trucks

Note: This technical tip is provided as technical information and is not authorization for a warrantable repair.

REPAIR PROCEDURE

1. The brake controller input is obtained from the stoplight relay circuit of the Hino chassis which is a red wire located at terminal COC of the stoplight relay. The stoplight relay is located behind the passenger side dash panel. The brake controller input will splice into the red wire of this circuit. (Refer to the following photo and diagrams)

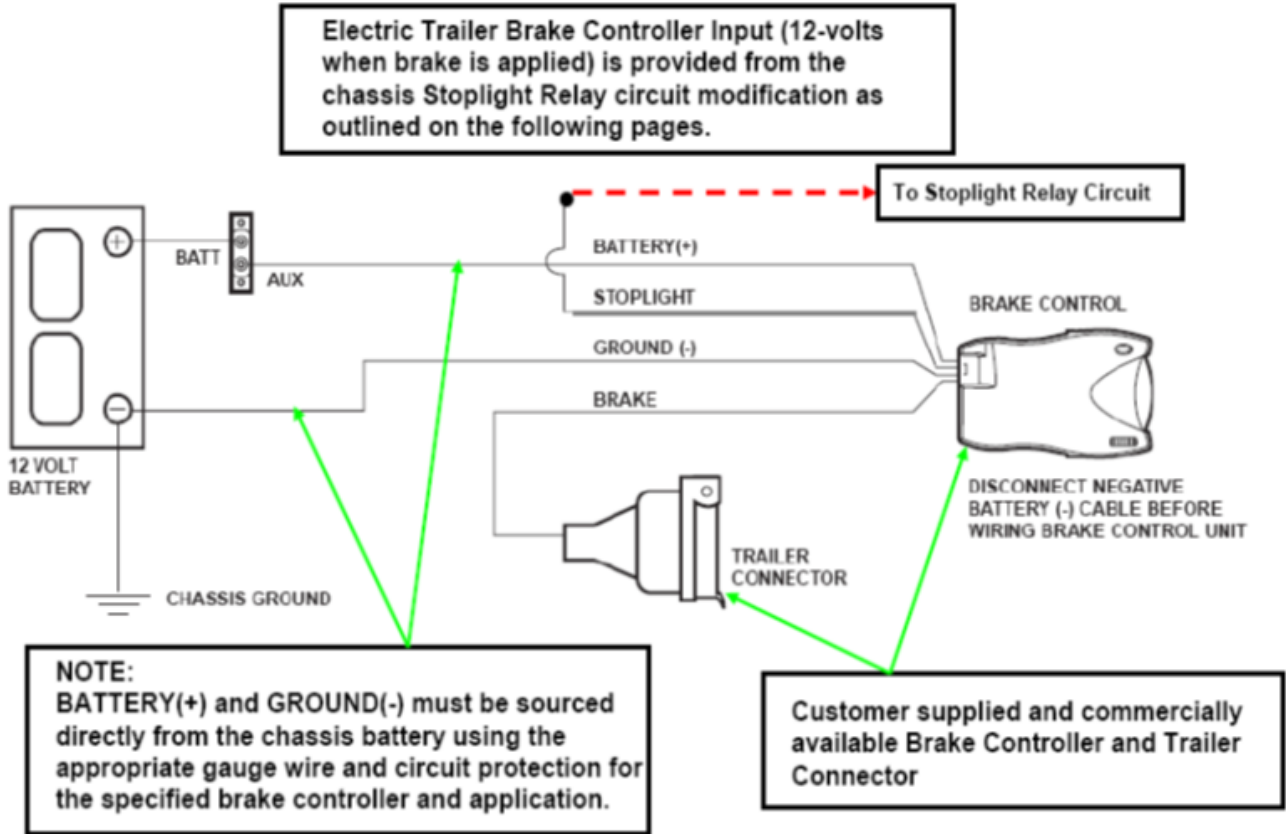

Group:	27-Electrical
Bulletin No.:	TT-14-019
Issue Date:	07-30-2014

TECH TIP

2. A 1-Amp inline fuse must be used between the splice into the stoplight relay circuit and the brake controller and shall be located as close as possible to the splice.



****Electric Trailer Brake Controller Splice Location**

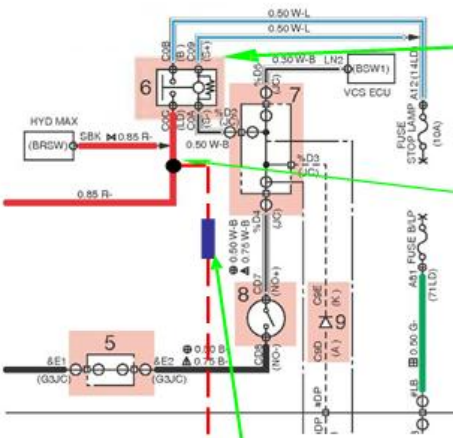

*** Stoplight Relay**

Stoplight Relay*
Brake pedal depressed shall provide 12-volt input to trailer brake controller from the **RED** wire.

Trailer Brake Controller Splice Location**
IMPORTANT NOTES:
•Fuse circuit to trailer brake controller with a 1 AMP inline fuse to protect vehicle circuit.
•Use only **3M SSC2001 Solder Splice Connector** or equivalent for circuit splices - See attached 3M Data Sheet.

1-Amp Inline Fuse

Input to Electric Trailer Brake Control Module

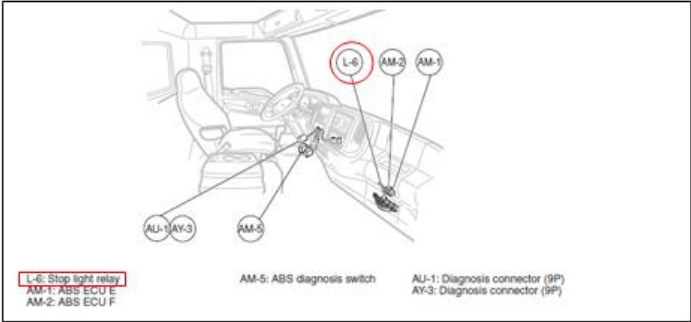

TECH TIP

3. Splice connections (including the inline fuse) shall use a 3M SSC2001 Solder Splice Connector or equivalent.

Recommended Solder Splice Connector for Electric Trailer Brake Controller Application

3M SSC 200x Series Solder Splice Connectors

Data Sheet

Ingenious, patented design

The 3M™ SSC 200x is a one-piece design. It is insulated with a flame retardant, heat-shrinkable sleeve of 3M's new flexible THV fluoropolymer. THV offers outstanding clarity of the insulating sleeve which allows easy inspection of the connection. Inside the sleeve are colored thermoplastic sealing dams and a wire-locking barrel with a fluxed solder disk.

After the wires are inserted and held in place by the barrel wire locks, heat is applied and three events occur:

- The solder disk melts and connects the wires
- The thermoplastic dams melt and flow, forming the moisture seal
- The sleeve shrinks, forming the electrical insulation

Construction Detail

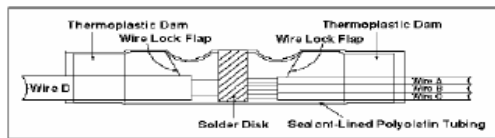

Product Description

3M SSC 200x Comes in four sizes, identified by color of sealing dam.

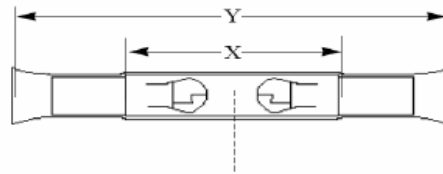

Model	Color	X (in.) nominal	Y (in.) nominal	I.D. (in.) nominal
SSC 2000	White	0.57	0.98	0.09
SSC 2001	Red	0.83	1.54	0.14
SSC 2002	Blue	1.00	1.93	0.21
SSC 2003	Yellow	1.25	2.40	0.26

Size selection

Generally, the SSC 200x works well with any wire or combination of wires that can be easily inserted. Tables 1 and 2 may be used as a general guide. Note: Insulation thickness is an important consideration in choosing the correct size SSC 200x. The size recommendations in Tables 1 and 2 are based on typical insulation thickness, in some cases you may need to use a Solder Splice Connector that is a different size from the one indicated in the Tables. In that case, the way to determine the correct connector size is to experiment with the different SSC 200x sizes and the specific wires to be spliced. Remember, 3M Solder Splice Connectors are not tied to specific wire gauges; each reliably splices a wide range of sizes.

Table 1: Single-wire to Single-wire Connections.

Part Number	Color	Wire Size (AWG)
SSC 2000	White	28-20
SSC 2001	Red	22-16
SSC 2002	Blue	20-14
SSC 2003	Yellow	14-8

Select smallest applicable size

Table 2: Two or three wires per side of Splice.

Part No.	Wire Gauge (AWG)										
	28	26	24	22	20	18	16	14	12	10	8
SSC2000	1-3	1-2	1-2	1-2	1						
SSC2001			1-2	1-2	1	1	1	1			
SSC2002				1-3	1-3	1-2	1-2	1	1	1	
SSC2003					1-3	1-3	1-2	1-2	1-2	1	1

Recommended Solder Splice SCC2001

Table 3: Typical Properties

Shrinkable sleeve	Transparent, radiation cross-linked fluoro-terpolymer (3M THV) that meets MIL-DTL-23053/18 Class 3. Tubing is flame retardant.
Sealing Inserts	Melttable fluorinated thermoplastic.
Wire pull-out Strength	Wire failure or 125 lbs. min.
Service Temperature	-55°C to 150°C
Solder Preform	43% lead, 43% tin, 14% bismuth per Federal Specification QQ-S-571 with non-corrosive flux.
Barrel	Tin-Plated cartridge brass.
Voltage Drop	0 - 1 mV
Dielectric Strength (outer sleeve)	10 kV min.
Resistance	0.5 milliohms max.
Sealing Performance (immersed in saline)	0.250 micro amps max.

Specifications: UL File E165969-UL Approved for selected wire combinations for 600V and 150°C. Approved on U.S Army, Tank Automotive Command (TACOM) Drawing number 12420927, Issued April 5, 1995.