

Group:	33-Transmission
Bulletin No.:	SB-14-017
Issue Date:	09-04-2014

TECHNICAL SERVICE BULLETIN

08MY-10MY ALLISON TORQUE CONVERTER LOCKUP MODIFICATION

OVERVIEW

In the event that one of the subject vehicles is driven while the ABS warning lamp is illuminated, operation of the torque converter clutch will be suspended. Driving the vehicle with an ABS warning lamp illuminated can lead to overheating of the transmission fluid due to the torque converter clutch not functioning. A jumper harness has been made available that will allow operation of the torque converter clutch in the event that the vehicle is driven while the ABS warning lamp is illuminated.

NOTE: This procedure is provided as technical information and is not an authorization for a warranty repair.

SUBJECT VEHICLES

2008MY – 2010MY Hino Conventional ND8J, NE8J, NJ8J, and NV8J vehicles equipped with an Allison transmission.

BEFORE YOU BEGIN:

- Read and understand all instructions and procedures before you begin the work.
- Read and follow all WARNINGS and NOTICES set forth in this publication. These alerts help to avoid damage to components, serious personal injury, or both.
- Park the vehicle on a flat, level and solid surface.
- Place the gear shift lever in "Neutral" or "Park".
- Apply the parking brake firmly and confirm parking brake activation.
- Turn off the engine and remove the key from the ignition switch.
- Always wear safety glasses or goggles to protect your eyes.

Place wheel chocks in front of and behind all the wheels to prevent the vehicle from moving.

NOTE: Because of the similarity in the procedures with respect to 2005MY-2007MY, 2008MY-2010MY and 2011MY-2014MY make certain that you are using the procedure applicable to the model year of the vehicle you are working on. The procedures differ from one model year group to another model year group.

PARTS

PART NUMBER	DESCRIPTION	QUANTITY
S859202840	Relay	2
82989E0080	2008MY - 2014MY Harness	1

TECHNICAL SERVICE BULLETIN

VEHICLE PREPARATION:

1. Park the vehicle on level ground.

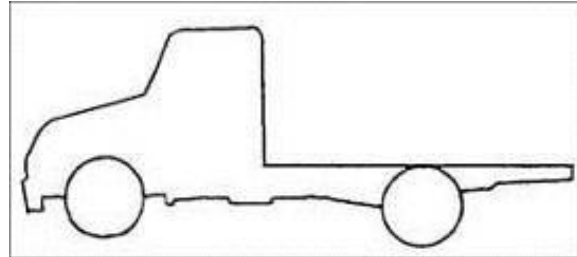

2. Confirm the engine is stopped, the ignition switch in the off (LOCK) position and the key is removed.



3. Apply the parking brake.



Group:	33-Transmission
Bulletin No.:	SB-14-017
Issue Date:	09-04-2014

TECHNICAL SERVICE BULLETIN

4. Chock the front wheels.



REPAIR PROCEDURE

1. Remove the battery cover. Remove the nut from the front negative battery terminal. Remove the chassis ground cable from the front battery. Tape the end of the battery cable to prevent contact with the battery terminal.

NOTICE: Do not discard the battery terminal nut. It will be reused during the assembly procedure.

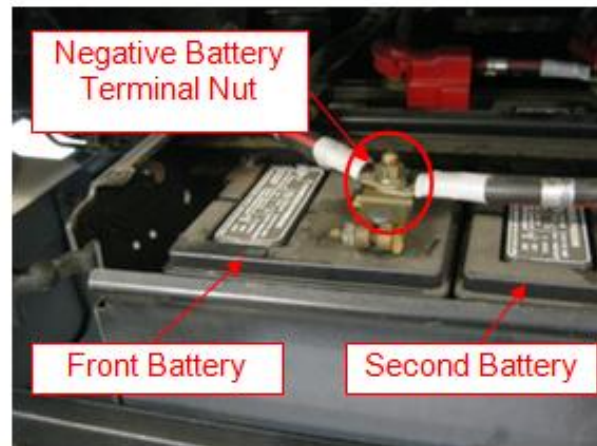

2. Remove the fuse panel cover on the passenger side of the instrument panel.



TECHNICAL SERVICE BULLETIN

3. Remove the 2 bolts from the trim panel above the fuse panel. Remove the trim panel.



4. Unclip and remove the speaker grille.



5. Remove the 1 bolt and 1 clip at the bottom of the right finish panel. Remove the one clip at the top of the right finish panel. Remove the right finish panel from the instrument panel.



Group:	33-Transmission
Bulletin No.:	SB-14-017
Issue Date:	09-04-2014

TECHNICAL SERVICE BULLETIN

6. Remove the 3 bolts from the fuse panel. Roll the fuse panel forward to access the back side of the fuse panel.

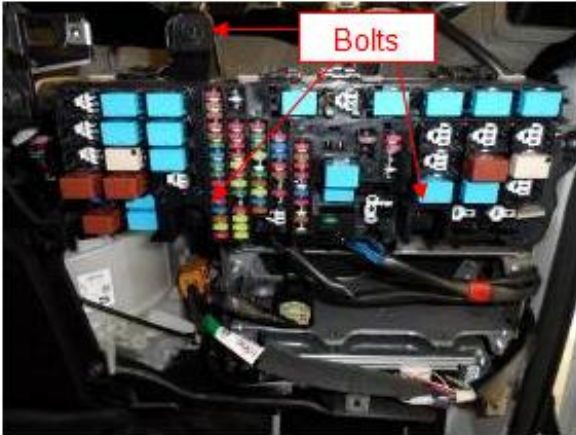

7. Release the 9 locking tabs on the back fuse panel cover. Remove the cover.

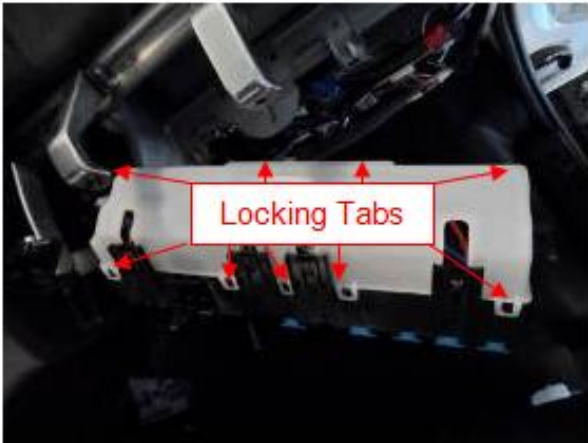

8. Clip the new wire harness relay block (82989E0080) onto the top of the fuse panel. Install the two relays (S859202840) into the relay block.

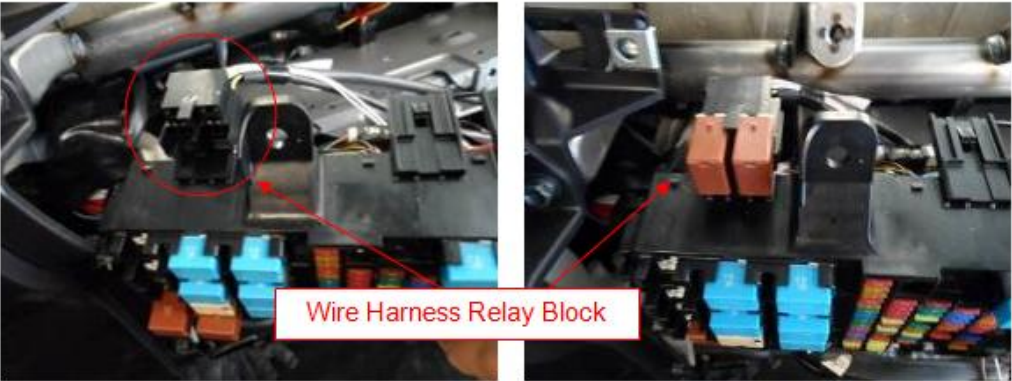

TECHNICAL SERVICE BULLETIN

9. Remove and discard the wire ties that secure the wire harness to the fuse panel. Remove and discard the electrical tape that binds the harness together.

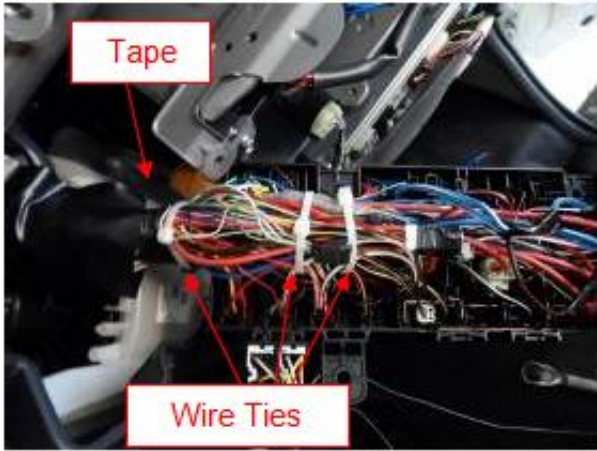

10. Locate the ABS EXH CUT Relay. This relay is on the left hand side, fourth relay down in the fuse panel. Locate the ABS EXH CUT wire leads on the back side of the fuse panel. Locate the White/Red wire connected to terminal S0E. Without cutting the wire, strip back one inch (25mm) of the insulation from the White/Red wire.

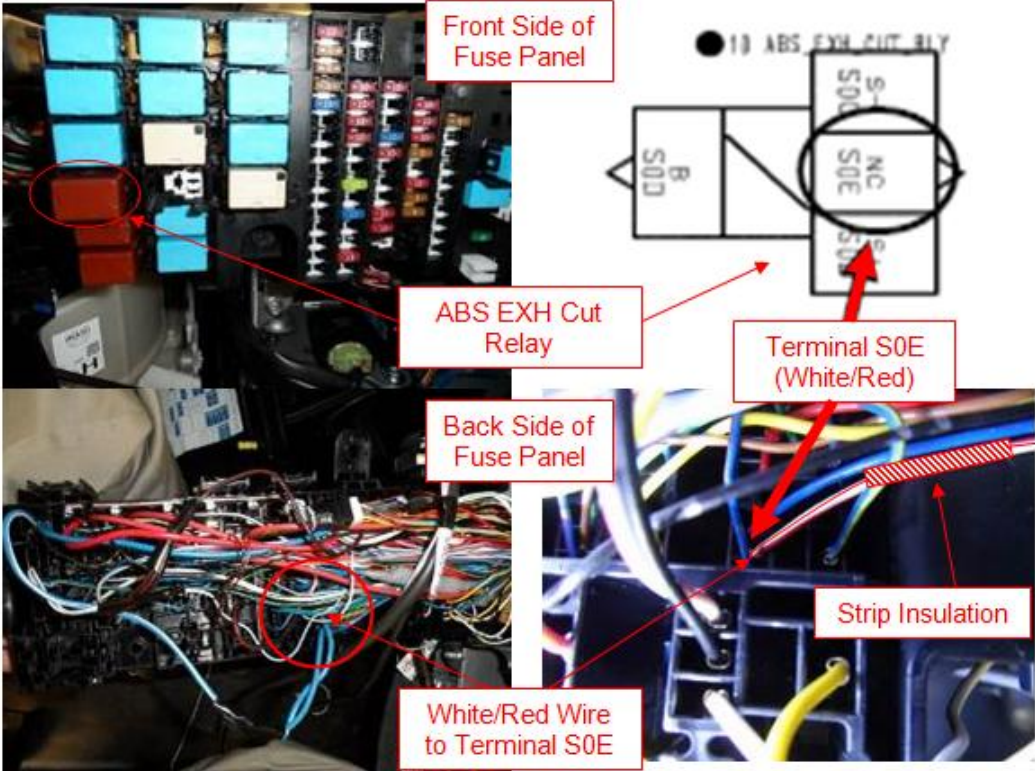

Group:	33-Transmission
Bulletin No.:	SB-14-017
Issue Date:	09-04-2014

TECHNICAL SERVICE BULLETIN

11. Find the White/Red wire coming from the relay block on the new harness. This wire will be tied into the White/Red wire that was stripped during the previous step. Cut the new White/Red wire to an appropriate length. Strip back one inch (25mm) of insulation from the end of the new wire. Solder the 2 wires together. Wrap the exposed section of wire with electrical tape.

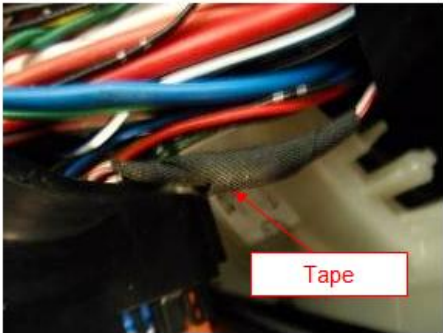
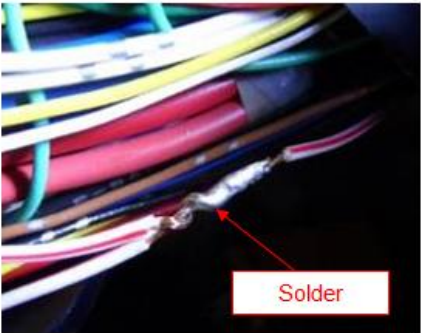

12. Locate the 10 amp ATM fuse on the fuse panel. Locate the White/Blue wire coming out of the back of the ATM fuse. Without cutting the wire, strip one inch (25mm) of insulation back from the White/Blue wire.

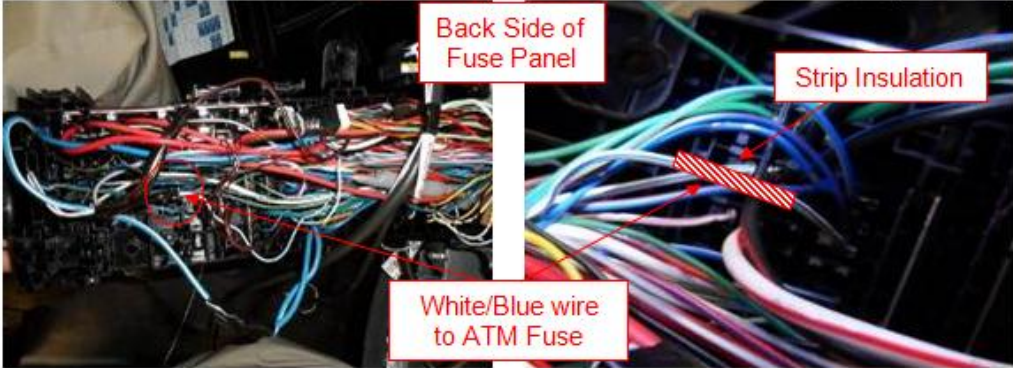
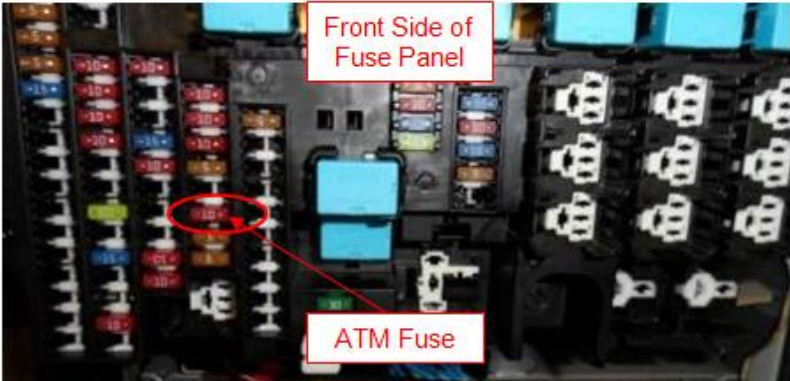

Group:	33-Transmission
Bulletin No.:	SB-14-017
Issue Date:	09-04-2014

TECHNICAL SERVICE BULLETIN

13. Find the White/Blue wire coming from the relay on the new harness. This wire will be tied into the White/Blue wire that was stripped during the previous step. Cut the wire to an appropriate length. Strip back one inch (25mm) of insulation from the end of the new White/Blue wire. Solder the 2 wires together. Wrap the exposed section of wire with electrical tape.

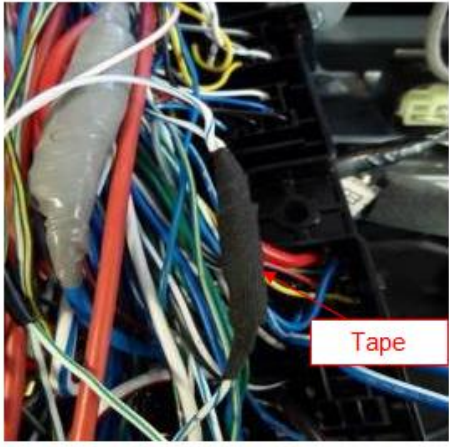

14. Install wire ties to secure the wire harness to the fuse panel. Wrap the end of the harness with electrical tape to bind the wires together.

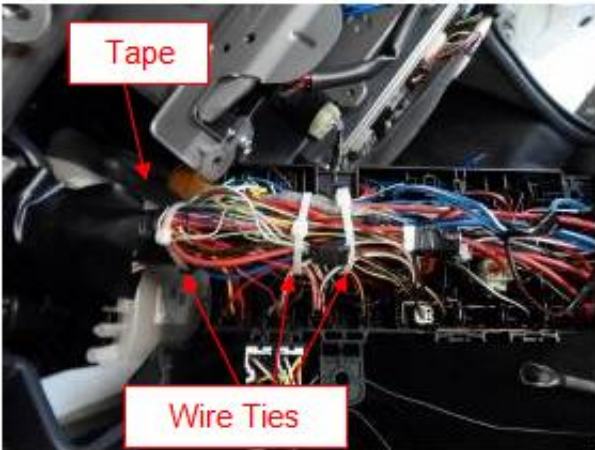

15. Reinstall the fuse panel cover. Route the insulated wires from the relay block on the new harness through the open end of the fuse panel cover.

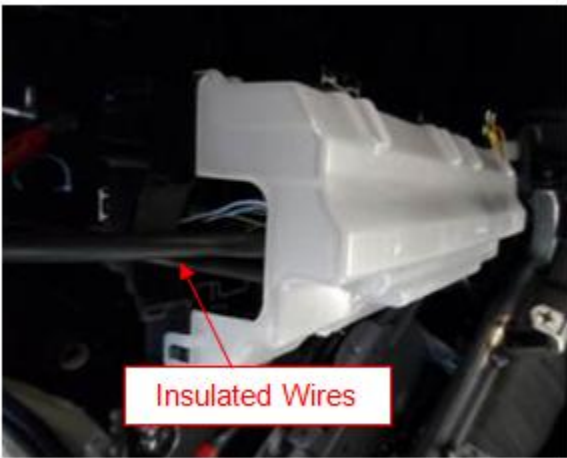

TECHNICAL SERVICE BULLETIN

16. Route the 2 insulated wires behind the ECU rack so that they hang down towards the bulkhead junction box.



17. Install the 3 bolts that secure the fuse panel to the instrument panel bracket. Tighten the fuse panel bolts to the specified torque.

Specified Torque: 2.2 lb-ft (3 Nm)

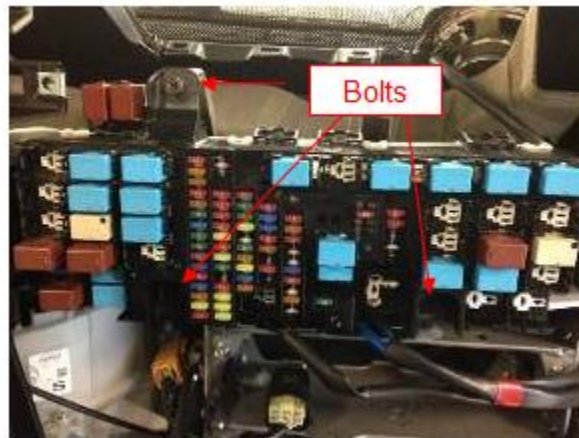

18. Remove the top left bolt in the ECU rack. Install the insulated ground wire coming from the relay block on the new harness using the bolt that was removed. Tighten the bolt the specified torque.

Specified Torque: 3.6 lb-ft (5 Nm)

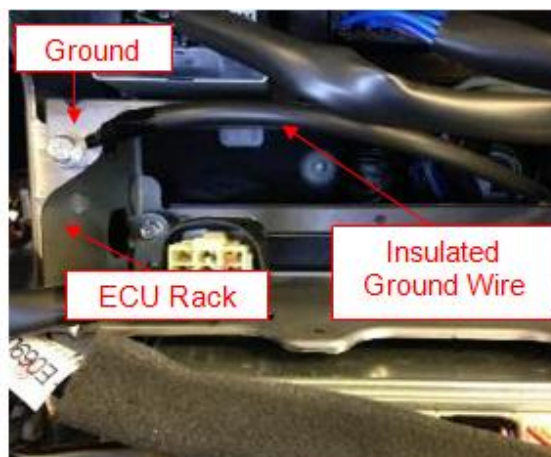

Group:	33-Transmission
Bulletin No.:	SB-14-017
Issue Date:	09-04-2014

TECHNICAL SERVICE BULLETIN

19. Remove the 4 bolts that retain the ECU bracket to the ECU rack. Slide the ECU slightly forward.

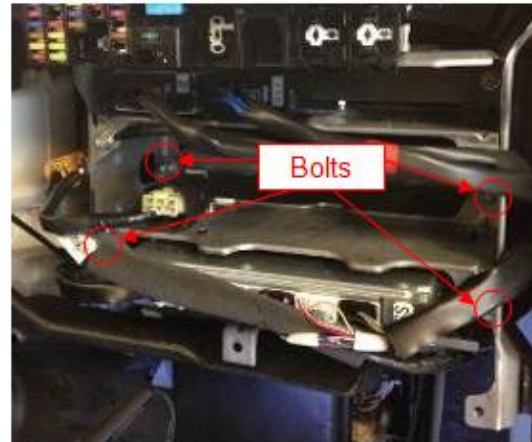

20. Release the 6 locking tabs and remove the inside cover from the bulkhead junction box.

NOTICE: Care should be taken not to break the locking tabs during removal.



Group:	33-Transmission
Bulletin No.:	SB-14-017
Issue Date:	09-04-2014

TECHNICAL SERVICE BULLETIN

21. Locate the yellow wire that connects to terminal #C6 in the junction box Main W/H to Frame W/H connector. Cut the wire 2 inches (50mm) from the connector. Strip back one inch (25mm) of insulation from the end of the wire coming out of the connector.

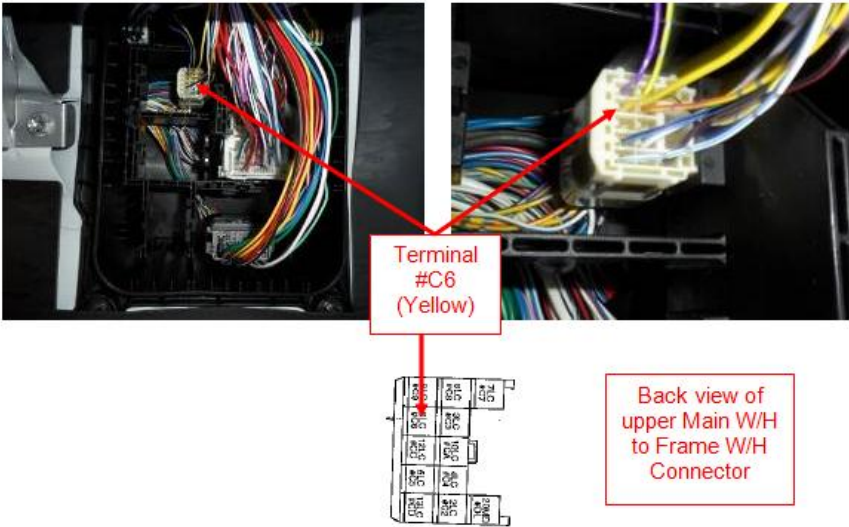

22. Find the insulated Yellow wire coming from the relay block on the new harness. This wire will be tied into the Yellow wire that was stripped during the previous step. Strip back one inch (25mm) of insulation from the end of the insulated yellow wire. Solder the 2 wires together. Wrap the exposed section of wire with electrical tape.

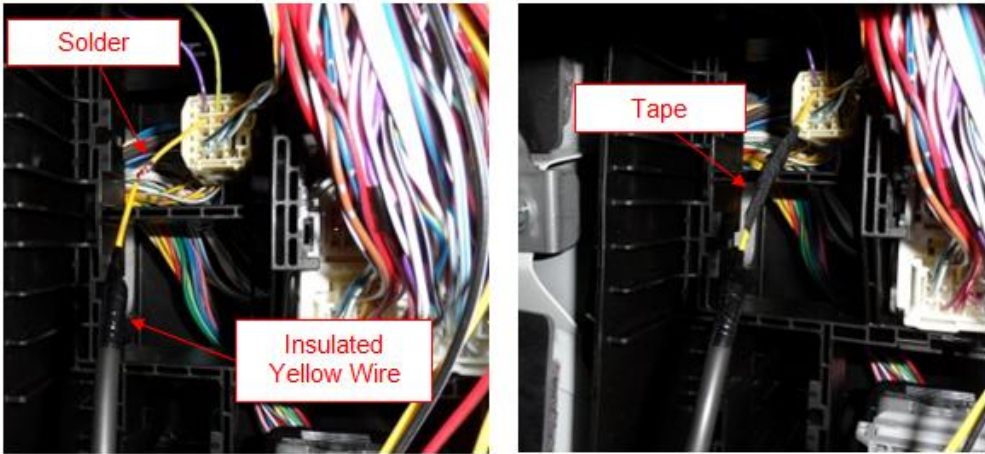

TECHNICAL SERVICE BULLETIN

23. The yellow cab side wire will no longer be used. Fold the end of the wire over, tape the wire to protect the exposed end, and tie the wire back into the harness.

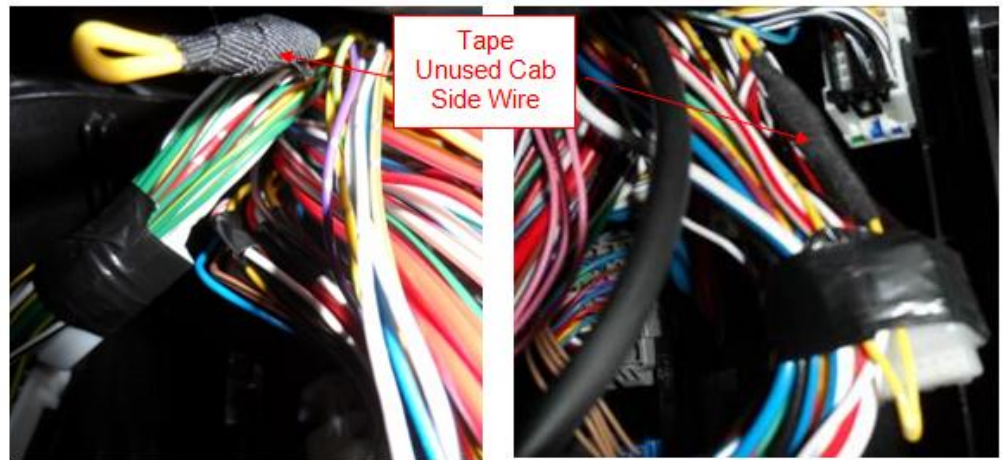

24. Route the insulated yellow wire so that it exits the top of the junction box alongside the other harnesses. The excess length of the insulated yellow wire can be coiled within the junction box. Reinstall the inside junction box cover.



25. Install the 4 bolts that retain the ECU bracket to the ECU rack. Tighten to the specified torque.

Specified Torque: 3.6 lb-ft (5 Nm)

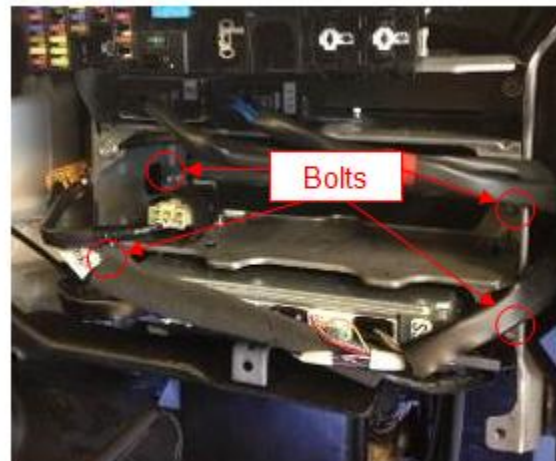

TECHNICAL SERVICE BULLETIN

26. Install the right finish panel to the instrument panel. Install the 1 bolt and 1 clip at the bottom of the right finish panel. Tighten the bolt to the specified torque. Install the one clip at the top of the right finish panel.



Specified Torque: 2.2 lb-ft (3 Nm)

27. Install the speaker grille.



28. Install the upper trim panel to the instrument panel. Install the 2 bolts into the trim panel above the fuse panel. Tighten the bolts to the specified torque.

Specified Torque: 2.2 lb-ft (3 Nm)

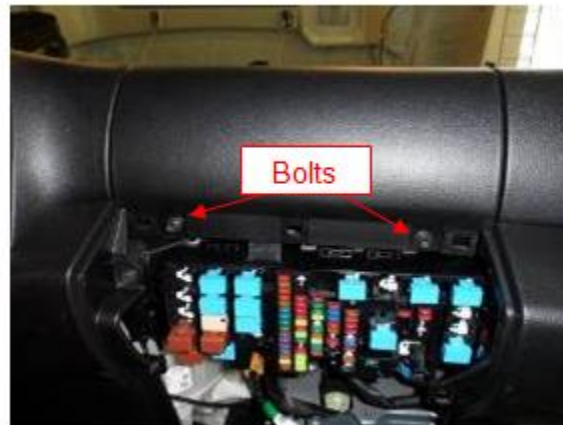

Group:	33-Transmission
Bulletin No.:	SB-14-017
Issue Date:	09-04-2014

TECHNICAL SERVICE BULLETIN

29. Install the fuse panel cover on the passenger side of the instrument panel.



30. Position the ground cable onto the negative battery terminal. Install the negative battery terminal nut. Tighten the nut to the specified torque. Install the battery cover. Proceed to the final inspection procedure, below.

Specified Torque: 8.1 lb-ft (11.0 Nm)

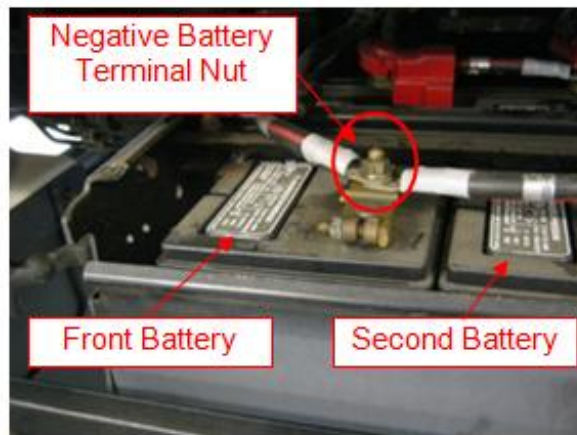

FINAL INSPECTION PROCEDURE:

1. To complete this technical service bulletin, review the bulletin and confirm the following:
 - All wires have been soldered and covered with electrical tape as outlined within this procedure
 - All nuts and bolts have been tightened to their specified torque
 - All trim panels and covers that were removed are securely installed

Group:	33-Transmission
Bulletin No.:	SB-14-017
Issue Date:	09-04-2014

TECHNICAL SERVICE BULLETIN

NOTE: This procedure is provided as technical information and is not an authorization for a warranty repair.

CLAIM APPLICATION:

** Reimbursable in accordance within the terms and policies of the Hino Truck limited warranties.*

- a) Labor charge: 1.2 hours
- b) Warranty code: 26000
- c) Trouble code: 99
- d) Operation code: 23850AOT
- e) Part Number: 82989E0080