

**SUBJECT****Engine Damage Due to Debris in Oil Passages****MODEL**

E90 335d (3 Series Sedan)

E70 xDrive 35d (X5)

F30 328d and 328d xDrive (3 Series Sedan)

F31 328d xDrive (3 Series Sports Wagon)

X3 xDrive28d (X3)

F10 535d and 535d xDrive (5 Series Sedan)

F15 xDrive 35d (X5)

F02 740Ld xDrive (7 Series)

SITUATION

After performing extensive engine repairs (e.g., cylinder head removal), the engine begins to knock and may lose power.

CAUSE

Debris has entered the engine oiling passages during cleaning of the engine block and cylinder head mating surfaces during engine repair.

CORRECTION

Once the cylinder head is removed from the engine block, the oil passage holes need to be properly covered to prevent debris from entering.

Only use cleaning set 90 88 6 114 470 (B04 07 14) to clean the surface of the block.

The following illustrations identify the oil passage holes (1) on current diesel engines.

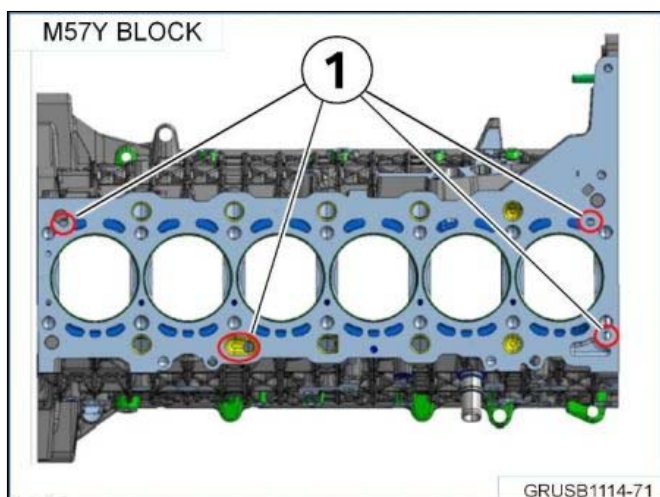

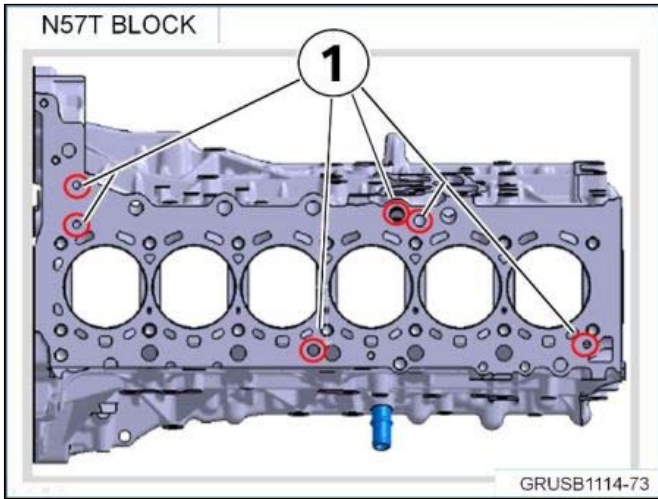
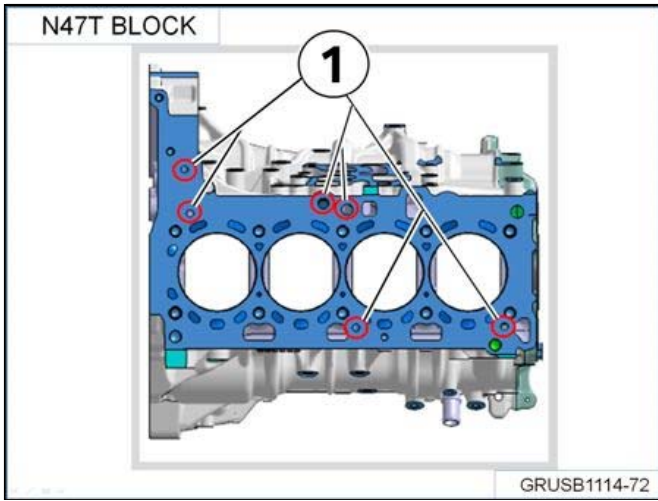

WARRANTY INFORMATION

Additional repairs to be performed due to the issue outlined in this bulletin are not a warranty matter.

[Copyright ©2014 BMW of North America, Inc.]