

**SUBJECT**

**M57 Diesel Engine Throttle Valve (for EGR): Limited Warranty Extension to 10 Years/120,000 Miles**

**MODEL**

E90 (3 Series Sedan 335d)

Model Year 2010

With the M57 diesel engine

**INFORMATION**

BMW of North America, LLC (“BMW NA”) is extending the limited warranty for the M57 diesel engine’s throttle valve (for EGR) on the above-referenced vehicle to:

**10 years/120,000 miles, whichever occurs first, as determined from the original in-service date.**

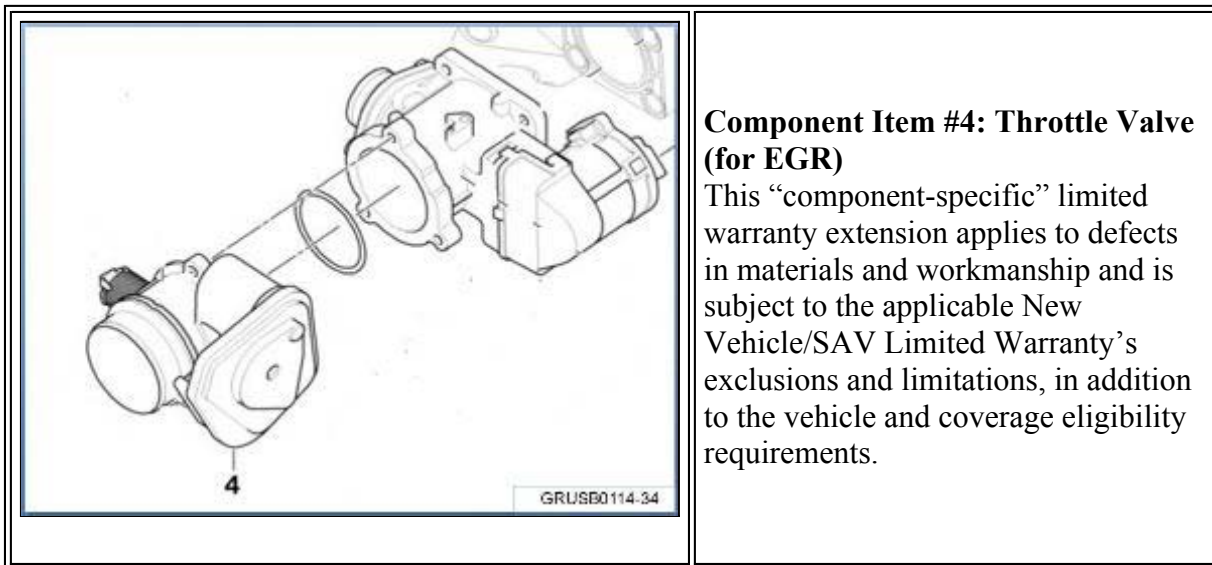

**This bulletin is a notice of a “limited warranty extension.” This is not a notice of a Recall or Service Action.**

There is no immediate repair required unless the BMW vehicle is currently experiencing this problem.

**Customer Notification Letter – VIN and Component-specific Warranty Extension**

Even though this is **NOT** a Recall, BMW NA sent VIN-specific customer notification letters. A sample letter is attached.

**Eligible BMW Vehicles**

To assist you in identifying eligible vehicles, the DCSnet Warranty Vehicle Inquiry has been updated with the following “Vehicle Comment,” shown below:

**BMW of North America, LLC has extended this vehicle’s M57 diesel engine throttle**

**valve (for EGR) limited warranty to 10 years or 120,000 miles, whichever occurs first, as determined from the original in-service date. Please see SI B01 12 14.**

**Note:** Always check the DCSnet Warranty Vehicle Inquiry “Vehicle Comments” and the “Repair History (Claims)” sections first before performing any repairs.

#### PARTS INFORMATION

Please refer to the Electronic Parts Catalog (EPC/ETK), using the customer’s VIN to locate the replacement part numbers.

**Note: Only order the necessary parts, in the quantities needed, for customers’ vehicles that have confirmed failures.**

Also, refer to ETK and the repair instructions for onetime-use fasteners and component information regarding additional and/or replacement screws, gaskets and seals that need to be installed and claimed.

#### WARRANTY INFORMATION

The M57 diesel engine’s throttle valve (for EGR) limited warranty extension to 10 years/120,000 miles, whichever occurs first, applies to “eligible US-specification BMW vehicles” that are registered, operated and have their covered repair performed by an authorized BMW center in the United States (including Puerto Rico).

The existing limited warranty coverage for all other parts **has not** changed.

Ineligible vehicles or the diagnosis and repair of other unrelated issues are not covered under this limited warranty extension.

Should the M57 diesel engine’s throttle valve (for EGR) fail again, this component is covered by the remaining portion of the extended limited warranty coverage period.

Claim this work with the defect code and KSD2 labor operations provided below.

<b>Defect Code:</b>	<b>11 71 90 98 00</b>	
<b>Labor Operation:</b>	<b>Labor Allowance:</b>	<b>Description:</b>
00 00 006	Refer to KSD2	Performing “vehicle test” (with vehicle diagnosis system – checking faults)
And:		
61 21 528	Refer to KSD2	Connect an approved battery charger/power supply (indicated in KSD2 as “Charging battery”)
And:		
61 00 006	Work time (WT)	Performing vehicle diagnosis – test module
And:		
11 71 525	Refer to KSD2	Removing and installing or replacing throttle valve (for EGR)

Labor operation code 00 00 006 is a Main labor operation. If you are using a Main labor code for another repair, use the Plus code labor operation 00 00 556 instead.

Refer to KSD2 for the corresponding flat rate unit (FRU) allowance. Enter the Chassis Number, which consists of the last 7 digits of the Vehicle Identification Number (VIN). Click on the “Search” button, and then enter the applicable flat rate labor operation in the FR code field.

Even though work time labor operation code 61 00 006 ends in “006,” it is not considered a Main labor operation.

Work time (WT) labor operation 61 00 006 requires an individual punch time and an explanation in the claim comments section.

### Additional work as Necessary

Labor Operation:	Labor Allowance:	Description:
11 99 000	Work time (WT)	Additional work to clean throttle valve for EGR-related components

Even though work time labor operation code 11 99 000 ends in “000,” it is not considered a Main labor operation.

Work time (WT) labor operation 11 99 000 requires an individual punch time.

### Sublet – Bulk Materials

Sublet Code 4	See sublet reimbursement calculation below	Reimbursement for repair-related bulk materials (Please do not use BMW part numbers for claim submission)
---------------	--	---

Sublet reimbursement calculation for claiming used quantities of repair-related bulk materials:

- BMW part numbers at dealer net plus handling; or
- Other materials **not available through BMW** and obtained locally are at cost plus 20 percent.

Enter this material cost in sublet and itemize the amount in the claim comment section.

### Previous Customer-pay Repairs – Limited Warranty Extension Reimbursement

As provided and outlined in the “Customer Notification” letter, under this extended limited warranty, BMW of North America, LLC will provide reimbursement for “qualifying customer-pay repairs” that were performed on an eligible vehicle prior to the release of the customer notification.

Customer pay repairs, when they were performed, are subject to the applicable New Vehicle/SAV Limited Warranty’s exclusions and limitations, in addition to the vehicle and coverage eligibility requirements.

Repairs performed on ineligible vehicles or the diagnosis and repair of other unrelated issues do not qualify for reimbursement.

For a customer to request reimbursement for a “qualifying customer-pay repair” performed either by an authorized BMW center or independent repair shop, please have him/her submit his/her reimbursement request online at [www.BMW-RP.com](http://www.BMW-RP.com).

This website provides information regarding the required supporting documentation and alternative methods to submit a reimbursement request.

**ATTACHMENTS**

View PDF attachment [\*\*B011214 EGR Throttle Valve Sample Customer Letter.\*\*](#)

[ Copyright ©2014 BMW of North America, Inc. ]