



## SUBJECT

### Door Opens to First Stage While Driving

## MODEL

F15 (X5)

Produced from June 30, 2013

With option 323 (Soft Close)

## SITUATION

The door opens to the first stage and the Check Control Message (CCM) is displayed.

## CAUSE

Front or rear door lock Bowden cable cover and the door lock

## CORRECTION

Replace the Bowden cable cover and the door lock(s) as needed.

## PROCEDURE

Ask the customer these basic questions and find out what actually occurred:

- Which door opened or showed open?
- Did the door only open to the first stage?
- Did the Check Control Message (CCM) display the open door?
- Did the interior lights turn on?

There are two scenarios:

1. The interior lights turn on and/or the customer sees a CCM that one of the doors is open, even though that door is **closed**.

In this case, work through the appropriate test module, and check for any chaffed or shorted wiring related to the door lock.

2. The customer states the door opened to the **first stage**, the interior light came on and the CCM message for door open was displayed.

In this case, remove the door locks using REP 5121090 (front) and REP 5122090 (rear). Based on the date codes seen, all four door locks will be removed and possibly replaced, along with a new Bowden cable cover that you will modify.

**Scenario 2** – For reference, the Repair Instruction for the rear door lock removal procedure is shown in the next steps. Repair Instruction 5121090 should be referenced for the front door lock removal.



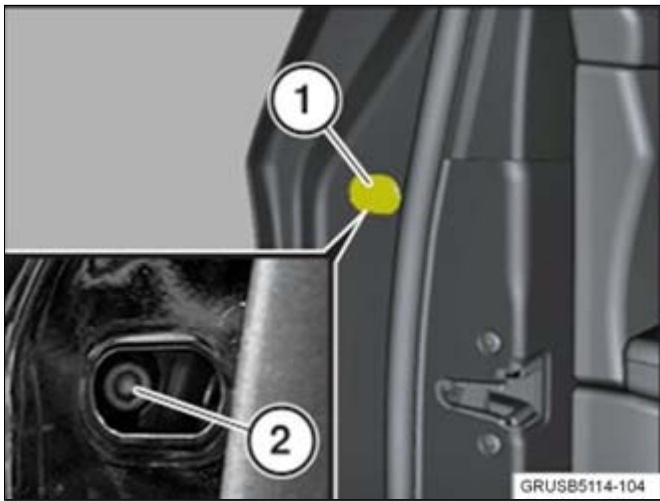

1. Pry out the trim cover (1) and remove the screw (2).

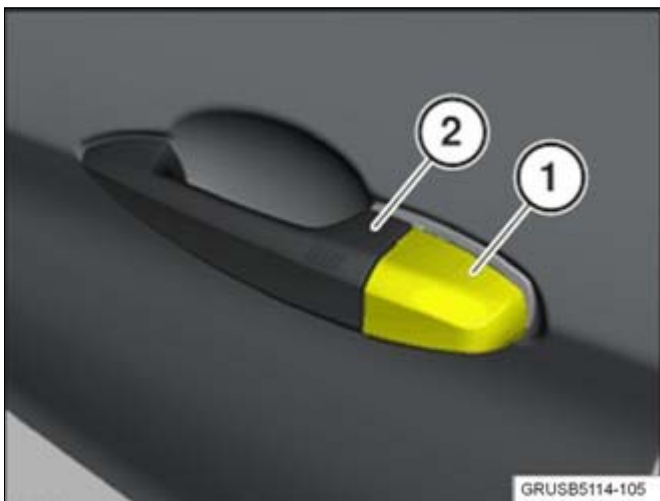

2. Pull the cover off (1) the door handle (2) by opening slightly.

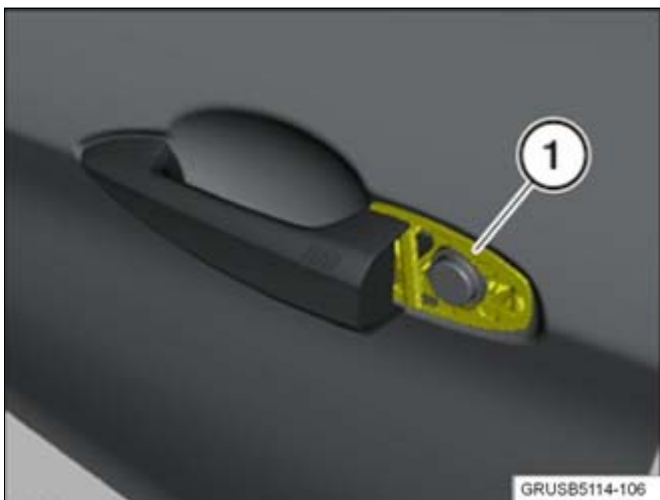

3. Installation note:  
Ensure the gasket (1) is seated correctly.

4. The latching mechanisms (1) of the cover (2) must not be damaged.

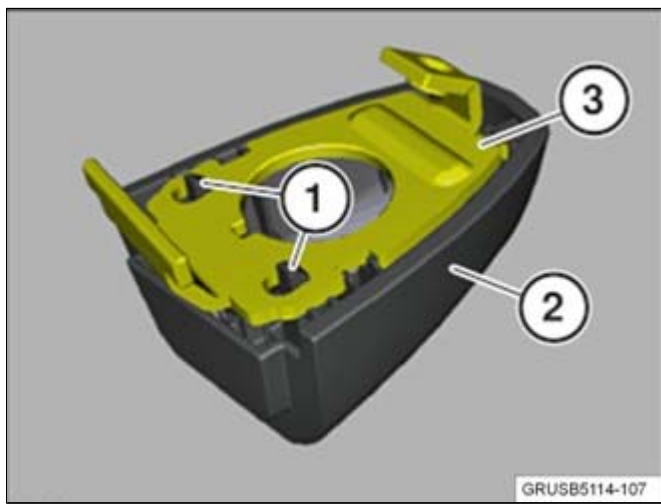

Replacement:

Remove the cover (2) from the retaining plate (3).

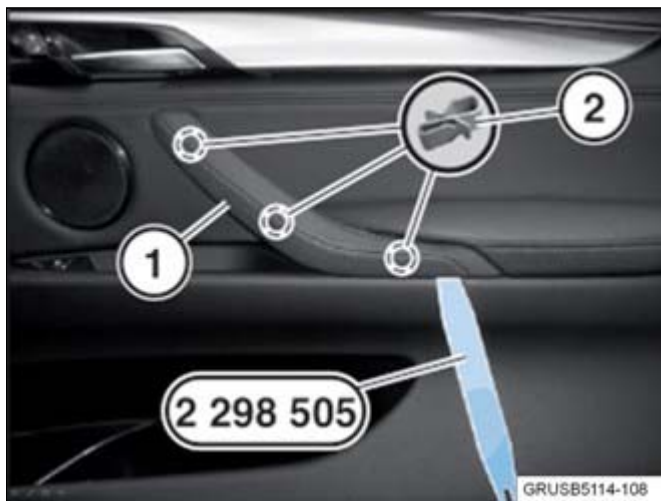

5. Pry the cover (1) from the clips (2) using special tool 2 298 505.

Installation note:

Replace any faulty clips (2).

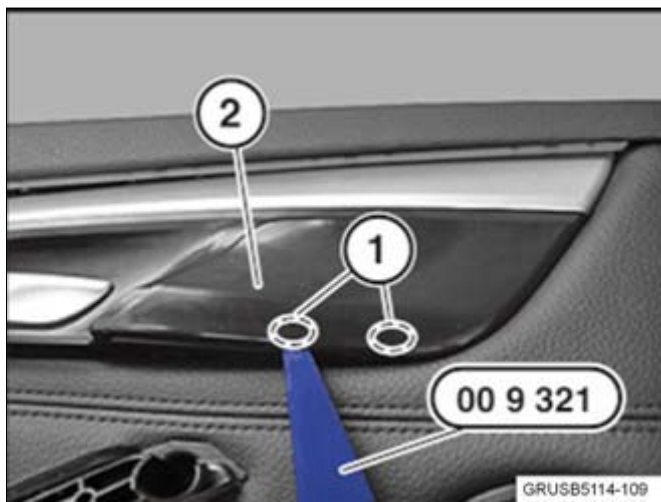

6. Pry the catches in area (1) using special tool 00 9 321. Unclip the trim (2).

7. Remove all screws from (1) and

(2).

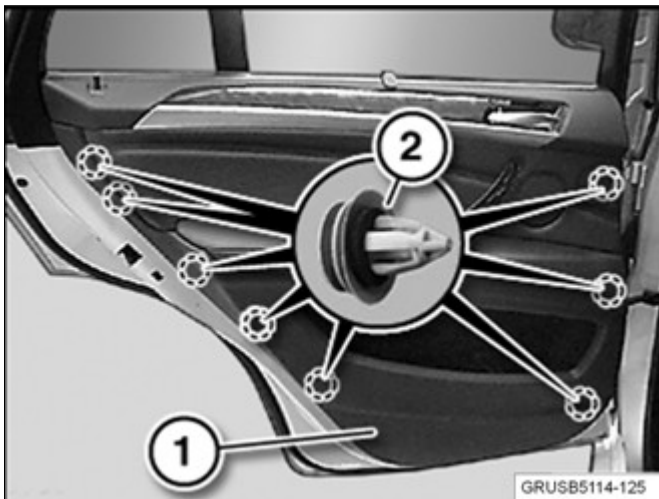
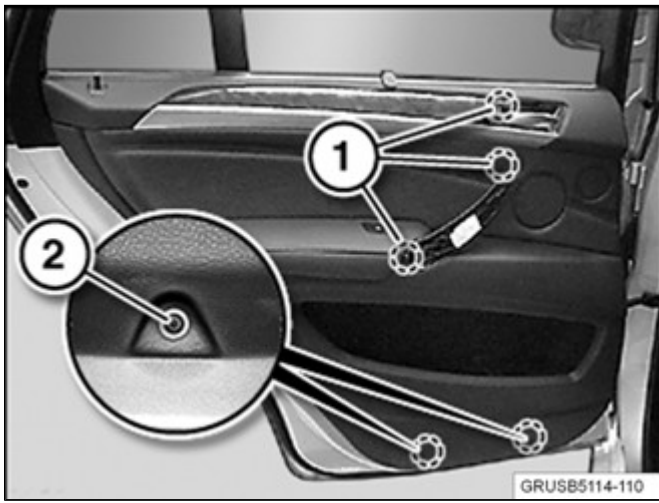

8. Unclip the door trim panel (1) from the clips (2) using special tool 00 9 325, starting from the B-pillar area.

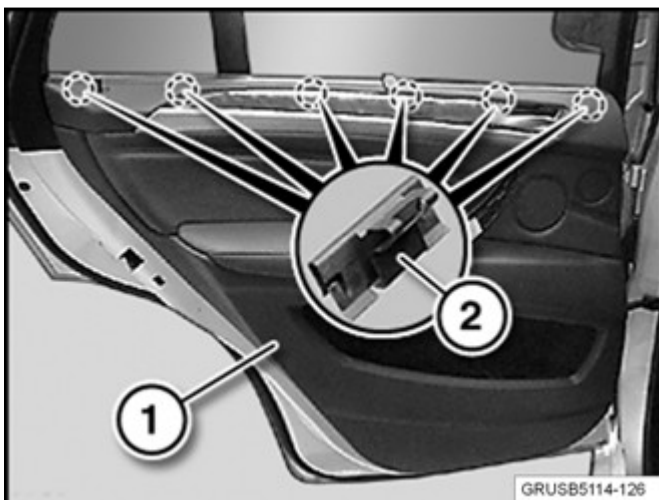

9. Carefully unclip the door trim panel (1) from the top retainers (2), and disconnect all plug connections.

10. Unhook the Bowden cable (1)

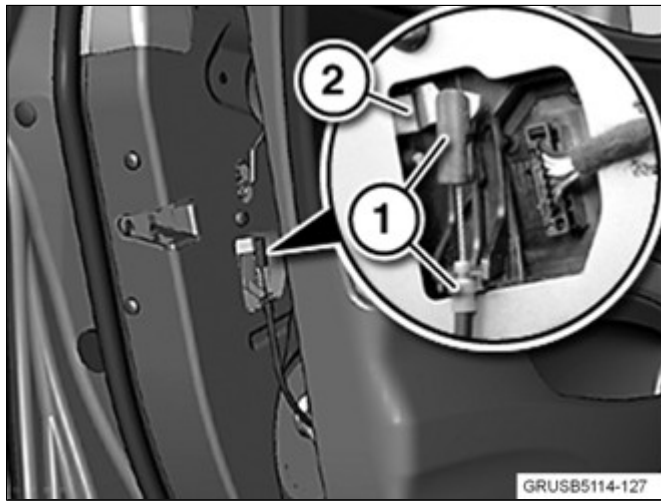

from the door lock (2).

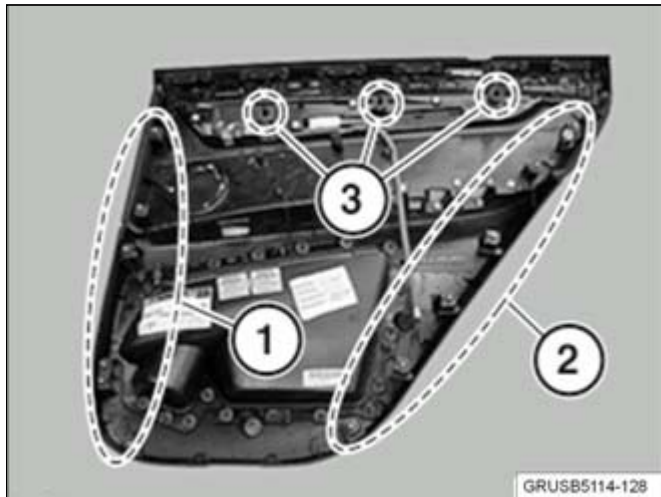

11. Note:

After each removal, all light blue clamps (2) must be replaced.

Installation note:

Replace any faulty clips (1 and 2).

Fit all clips with sealing rings.

Make sure the clips are installed in the correct position.

1 — Grey clip

2 — Light blue clip

Seals (3) must not be missing.

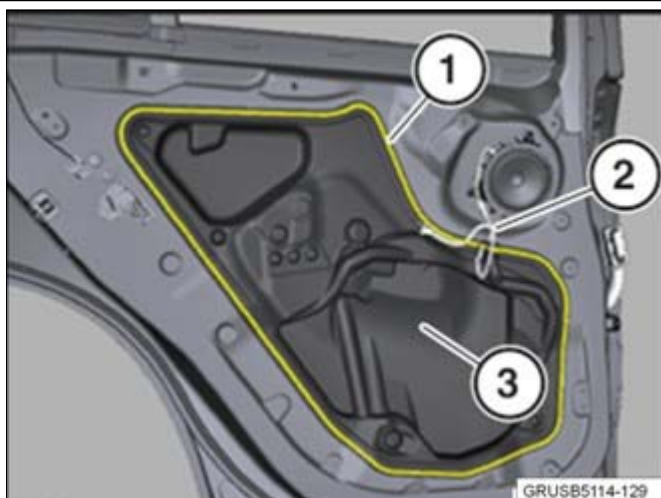

12. Note the position of the sealing bead (1). Pay special attention to the cable (2) when removing the sound insulation (3).

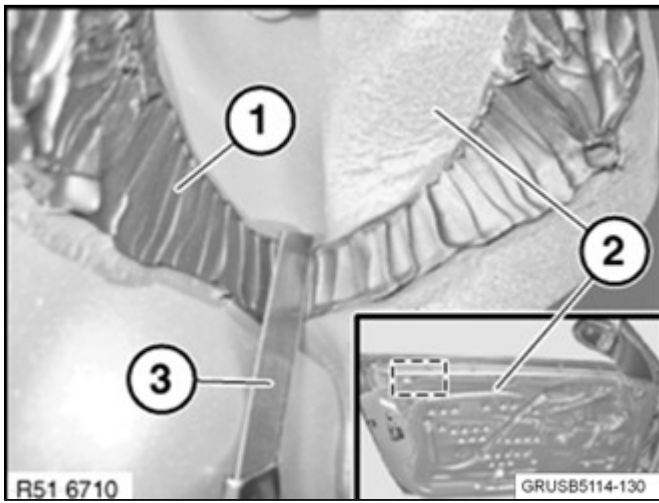

### 13. Important!

When cutting through the sealing bead (1), do not damage the sound insulation (2) or the cable. With a suitable sharp cutting tool (3), cut through the sealing bead (1) of the sound insulation (2) in the area to be detached.

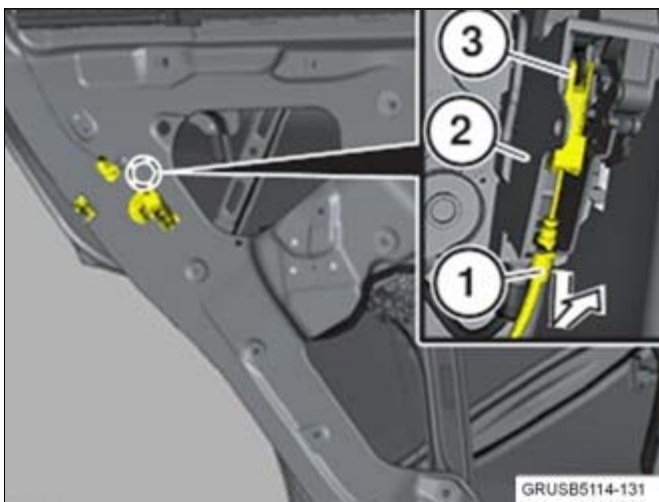

### 14. Version with Automatic Soft Close:

Disconnect the Bowden cable at the bottom (1) and top (3) from the door lock (2).

Installation note:

Pull the hook for the top cable (3) slightly downwards and hook on the cable. The Bowden cable must be correctly engaged in the locators of the door lock (2) and must be routed without kinking.

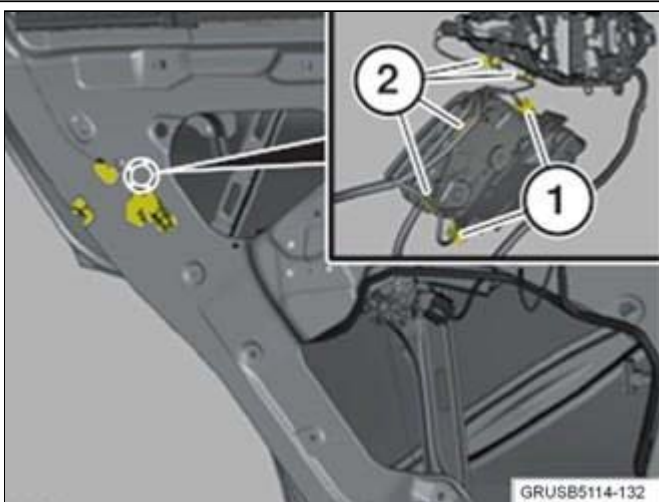

### 15. Unlock the plug connections (1) and disconnect the cable strap (2).

### 16. Loosen the bolt (1). Carefully remove the support (2) from the door.

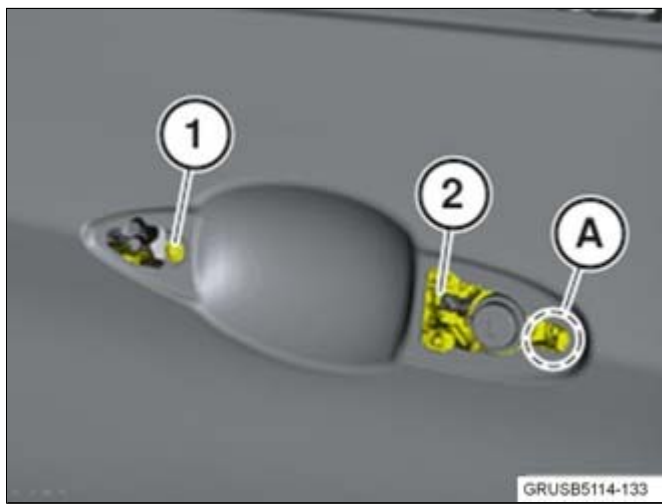

Installation note:

Make sure the support (2) in the area (A) is fitted correctly.

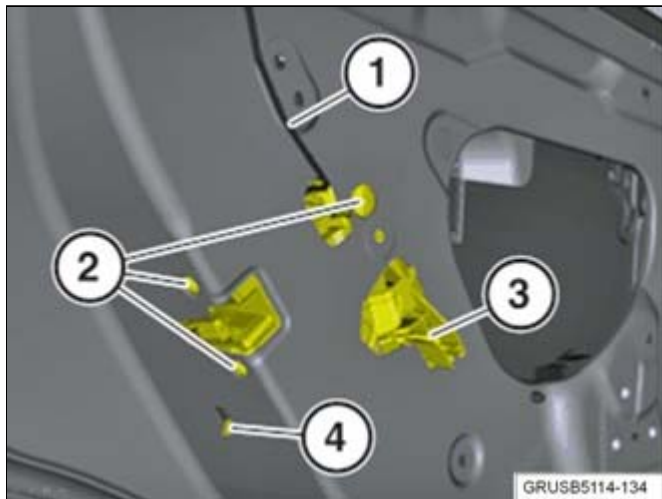

### 17. Important!

Do not damage the door lock seal when removing the door lock. Unclip the locking rod (1) and remove the screws (2). Remove the door lock (3) from the inside while supporting the outer door handle.

Installation note:

Observe the tightening sequence: bottom, top, and then inner.

Tightening torque: 8.5 Nm

Perform a function check of the child safety catch (4) and door lock (3) with the door opened.

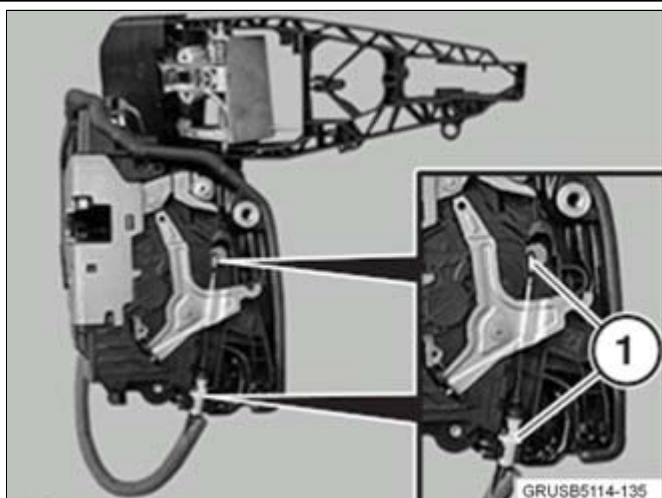

### 18. Disconnect the Bowden cable (1) and remove the door lock.

### 19. Remove the existing Bowden

cable cover from the lock and discard.

Check the date code on the door lock to see if it needs to be replaced as well. See step 21 below.

Modify the new Bowden cable cover by cutting off the guide tab (as shown) with a suitable tool (diagonal cutters, wiz wheel, etc.).

Complete the same procedure for the remaining three door locks.

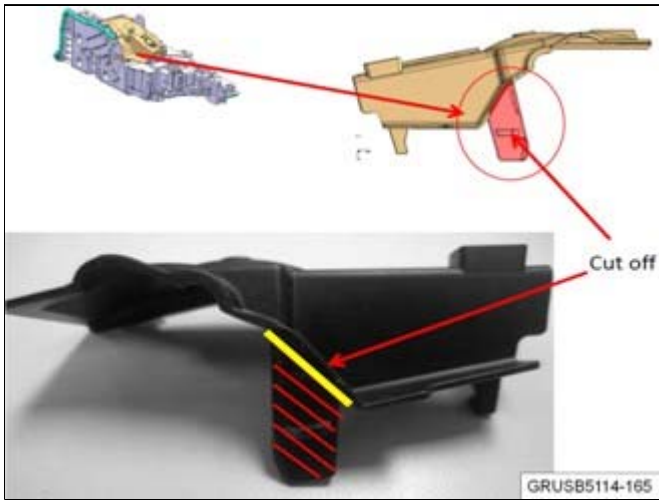

20. Note: The date code on the new Bowden cable cover must be 05 or higher.

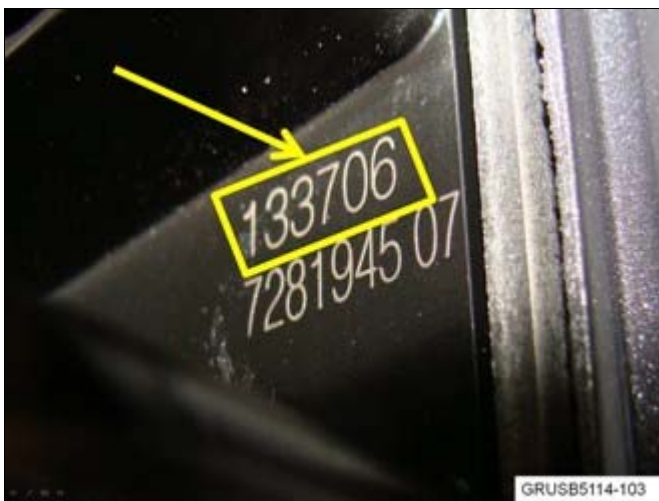

21. The date code on the left side door lock is on the upper line. The number (133706) translates to:

13 = year

37 = week

06 = day

The door lock code shown is a “good” code. The lock does not need to be replaced.

Any door lock with a date code older than 133602 must be replaced.

Note: The door lock code on the right side door locks is shown on



	the bottom line of numbers.
--	-----------------------------

The repairs performed should be four new modified Bowden cable covers on all four doors and replacement of any door lock with a date code older than 133602. Once confirmed, reinstall all removed parts in reverse order of their removal.

#### PARTS INFORMATION

Part Number	Description	Quantity
51 21 7 325 297	Left side Bowden cable cover	2
51 21 7 325 298	Right side Bowden cable cover	2
51 21 7 281 945	Front left side front door lock	One as needed
51 21 7 281 948	Front right side front door lock	One as needed
51 22 7 281 955	Left side rear door lock	One as needed
51 22 7 281 956	Right side rear door lock	One as needed

#### WARRANTY INFORMATION

Covered under the terms of the BMW New Vehicle/SAV Limited Warranty.

<b>Defect Code:</b>	<b>51 21 14 41 00</b>	
<b>Labor Operation:</b>	<b>Labor Allowance:</b>	<b>Description:</b>
51 21 110	KSD2	Removing and installing or replacing lock of both front doors
and		
51 22 610	KSD2	Removing and installing or replacing lock of both rear doors as plus work
and		
51 99 000	4 FRU	Work time required to modify the 4 new bowden cable covers

Labor operation code 51 21 110 is a Main labor operation. If you are using a Main labor code for another repair, use the Plus code labor operation 51 21 610 instead.

Refer to KSD2 for the corresponding flat rate unit (FRU) allowance. Enter the Chassis Number, which consists of the last 7 digits of the Vehicle Identification Number (VIN). Click on the “Search” button, and then enter the applicable flat rate labor operation in the FR code field.

Even though work time labor operation code 51 99 000 ends in “000,” it is not considered a Main labor operation. Also, since the “work time” FRU allowance to be claimed is specified, a separate punch time is not required.