

SUBJECT
N14 and N18 Engine: High-pressure Pump Repair Instruction
MODEL

R55

R56

R57

R58

R59

R60

R61

INFORMATION

The current version of ISTA/D Repair Instruction 13 51 017, “Removing and installing or replacing high-pressure pump (N14, N18)” has a procedure error. The current version of the Repair Instruction states to replace the high-pressure supply hose on the N14 engine. The Repair Instruction also states not to replace the high-pressure supply hose on the N18 engine. The N18 portion of the Repair Instruction is incorrect. As an interim solution, follow the procedure outlined below until this portion of the Repair Instruction is corrected.

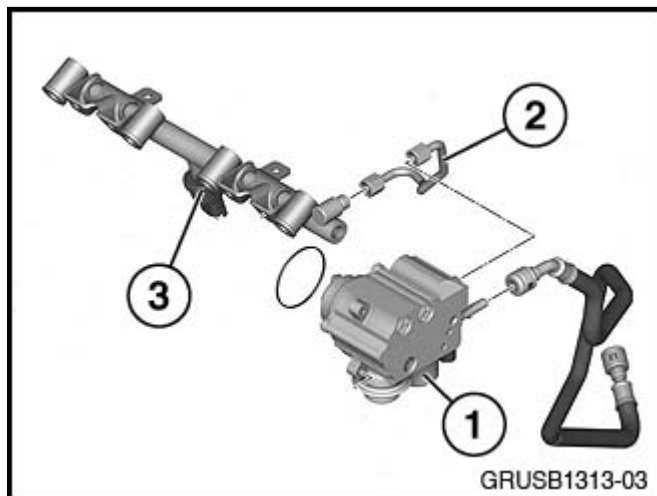
Continental High-pressure Pump (1):

All vehicles equipped with the N14 engine (all production)
 All N18 vehicles produced to 3/2012 are equipped with a Continental High-pressure Pump.
 When the N18 engine is fitted with a Continental High-pressure Pump (1), the high-pressure supply hose (2) **MUST** be replaced when making repairs.

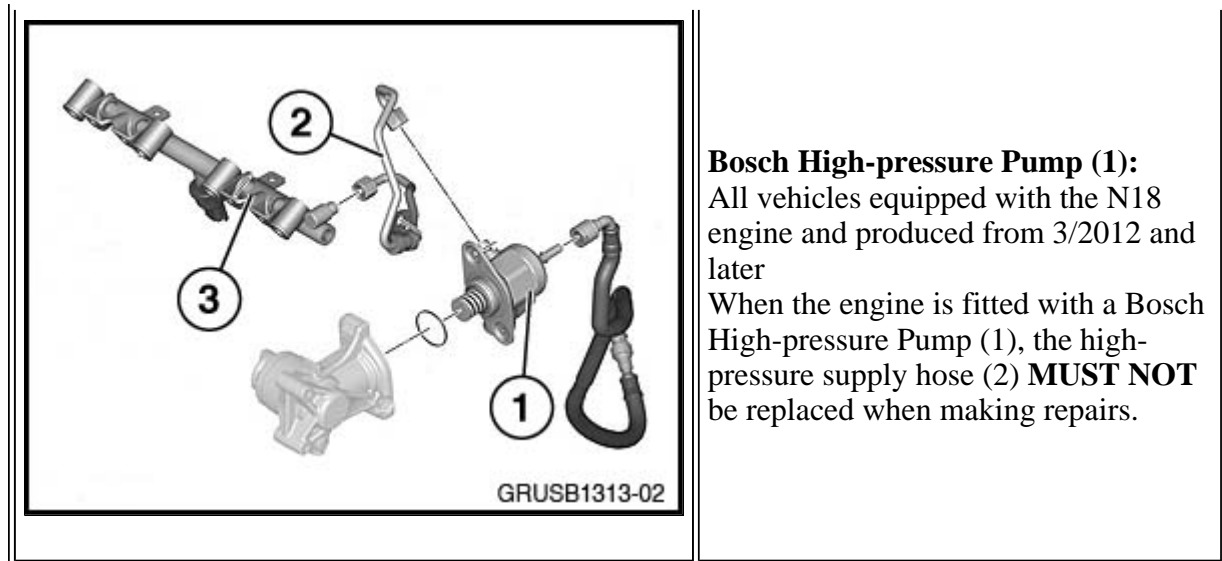
**Bosch High-pressure Pump (1):**

All vehicles equipped with the N18 engine and produced from 3/2012 and later

When the engine is fitted with a Bosch High-pressure Pump (1), the high-pressure supply hose (2) **MUST NOT** be replaced when making repairs.

The remaining portion of the Repair Instruction and tightening torques is correct.

Refer to EPC for the applicable part numbers when making repairs.

WARRANTY INFORMATION

Not applicable.

[Copyright ©2014 BMW of North America, Inc.]