

Roof Panel Pop Noise

Service Category Vehicle Exterior

Section Sliding Roof/Convertible

Market USA

Lexus Supports
ASE Certification 

Applicability

YEAR(S)	MODEL(S)	ADDITIONAL INFORMATION
2013	GS350, GS450H	

REVISION NOTICE

March 26, 2014 Rev1:

- Applicability has been updated to include 2013 model year GS 450h vehicles.
- The Production Change Information, Parts Information, and Repair Procedure sections have been updated.

Any previous printed versions of this bulletin should be discarded.

Introduction

Some 2013 GS 350 and GS 450h vehicles may exhibit a “pop” or “snap” type noise in the sunroof area of the roof panel, especially when entering driveways or travelling over bumps that induce a momentary body flex. This noise may be caused by an intermittent stick/slip condition between the sunroof housing and fasteners. Follow the procedure in this bulletin to address this condition.

Production Change Information

This bulletin applies to vehicles produced **BEFORE** the Production Change Effective VINs shown below.

MODEL	DRIVETRAIN	PRODUCTION CHANGE EFFECTIVE VIN
GS 350	2WD	JTHBE1BL#D5015380
	AWD	JTHCE1BL#D5011774
GS 450h	2WD	JTHBS1BL#D5004505

Parts Information

PART NUMBER		PART NAME	QTY
PREVIOUS	NEW		
90179-06216*	90179-06274	CZ Fastener Coating Nut (Black)	4

Roof Panel Pop Noise

Parts Information (Continued)

PART NUMBER		PART NAME	QTY
PREVIOUS	NEW		
	90177-06002	Lock nut (Silver)	4
	74611-33010-##	Assist Grip Cover	4
	74612-33020-##	Assist Grip Cover	4
	62217-30040 62217-52120**	Front Pillar Garnish Clip	2
	90467-10167	Upper Center Pillar Garnish Panel Clip	2

* 90179-06216 is a non-service part number used for production only. The EPC lists 90179-06274 as the service part number.

** Confirm applicable parts when ordering replacements.

Required Tools & Equipment

SPECIAL SERVICE TOOLS (SST)	PART NUMBER	QTY
Plastic Pry Tool Kit*	00002-06020-02	1

* Essential SST.

NOTE
Additional SSTs may be ordered by calling 1-800-933-8335.

TOOLS & MATERIAL	PART NUMBER	QTY
3M™ Semi Rigid Plastic Repair 50ml Cartridge or equivalent (if required)	PN34240	1
3M™ Polyolefin Adhesion Promoter – Aerosol Can or equivalent (if required)	PN05907	1

Warranty Information

OP CODE	DESCRIPTION	TIME	OFF	T1	T2
BD1218	R & R Sliding Roof Housing Sub-Assy	3.0	63203-30180	91	14

APPLICABLE WARRANTY

- This repair is covered under the Lexus Comprehensive Warranty. This warranty is in effect for 48 months or 50,000 miles, whichever occurs first, from the vehicle's in-service date.
- Warranty application is limited to occurrence of the specified condition described in this bulletin.

Roof Panel Pop Noise

Service Bulletin Overview

Read the entire Service Bulletin to fully understand the procedure to reduce the chance of damaging expensive interior components.

1. Confirm the condition described in the Introduction.
2. Remove the necessary interior garnishes and parts to gain access to the sliding roof mechanism mounting nuts.
3. Carefully unfasten the headliner taking care NOT to bend or damage the part to gain access to the sliding roof mounting nuts.

NOTE

It is NOT necessary to completely remove the headliner.

4. With the help of an assistant to prevent damage to the headliner, install the NEW sliding roof mounting nuts. Follow the nut installation procedure exactly as explained in this bulletin.
5. Reassemble and road test to confirm repair.

Roof Panel Pop Noise

Repair Procedure

Figure 1. Left and Right Side Parts Location

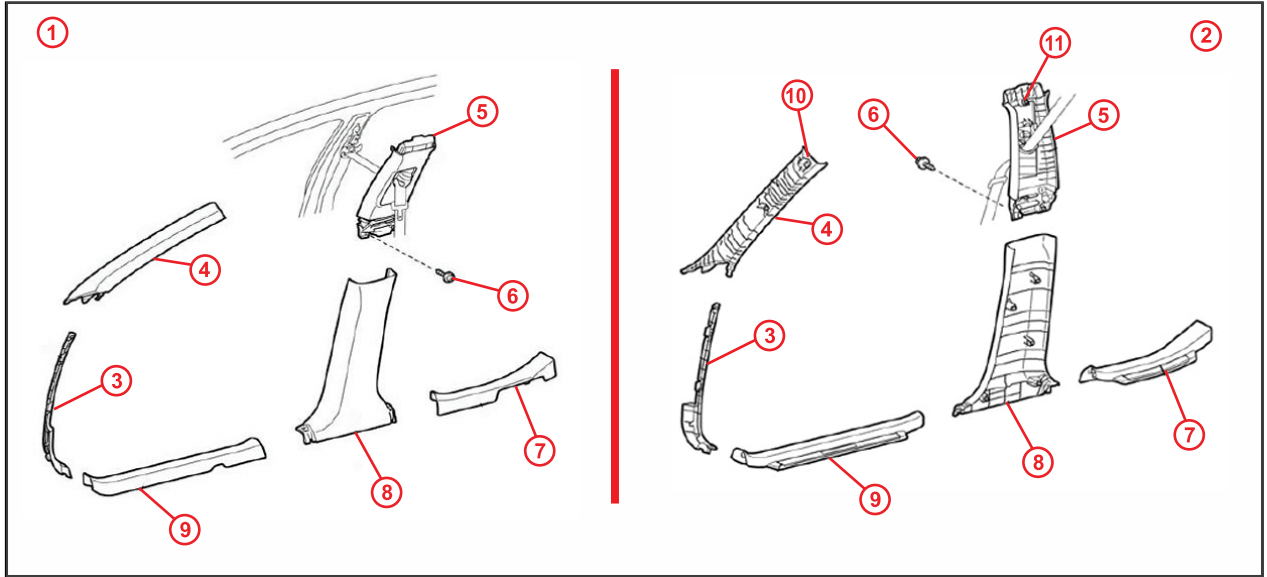

1	Left Side
2	Right Side
3	Front Door Opening Trim Cover
4	Front Pillar Garnish
5	Upper Center Pillar Garnish
6	Screw

7	Rear Door Scuff Plate
8	Lower Center Pillar Garnish
9	Front Door Scuff Plate
10	NEW Upper Front Pillar Garnish Clips (Required)
11	NEW Upper Center Pillar Garnish Clips (Required)

Roof Panel Pop Noise

Repair Procedure (Continued)

Figure 2. Visor and Map Light Assembly Overview

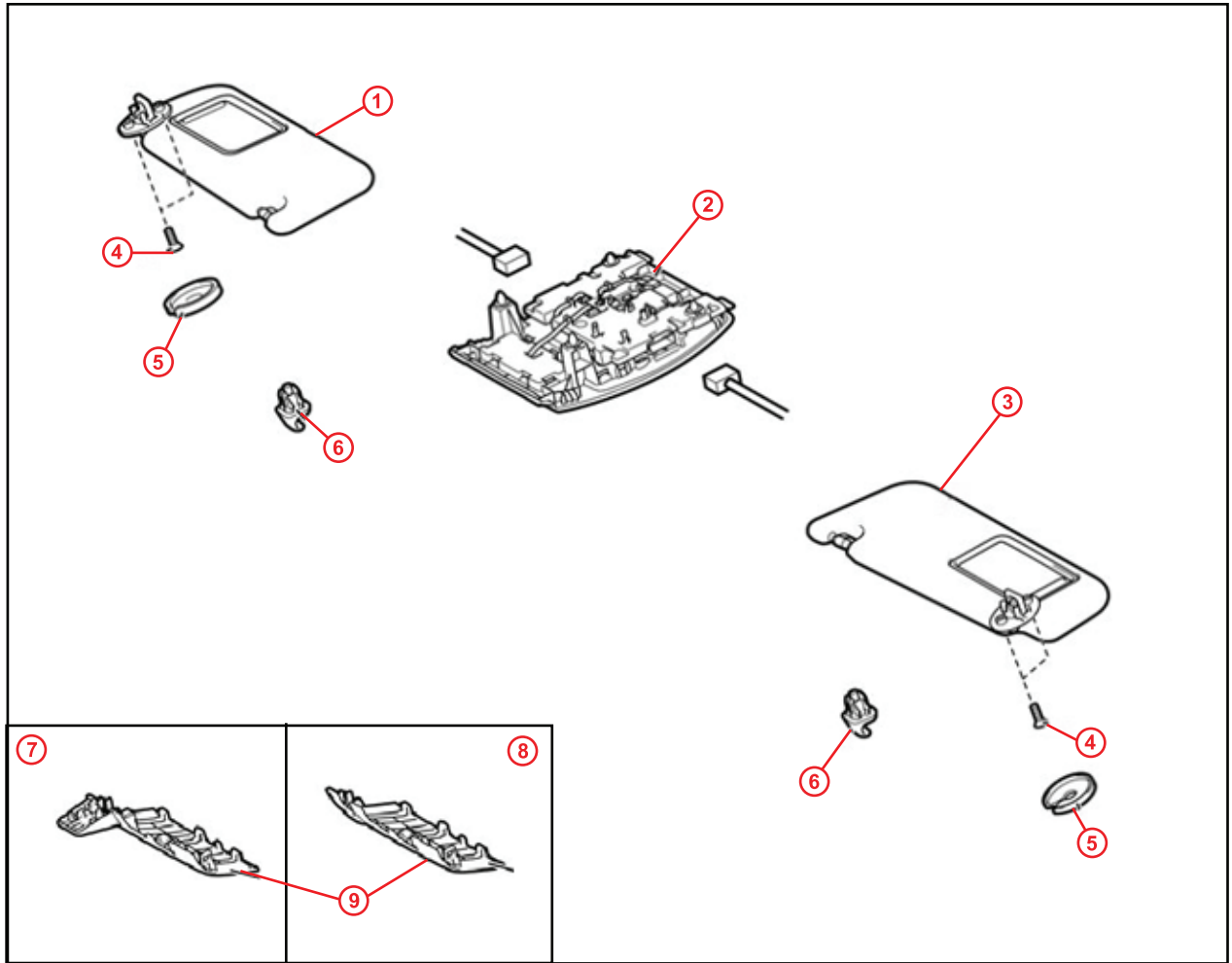

1	Visor Assembly RH
2	Map Light Assembly
3	Visor Assembly LH
4	Screw
5	Visor Bracket Cover

6	Visor Holder
7	With Night View System
8	Without Night View System
9	Front Roof Top Garnish

Roof Panel Pop Noise

Repair Procedure (Continued)

Figure 3. Roof Headlining Assembly Overview

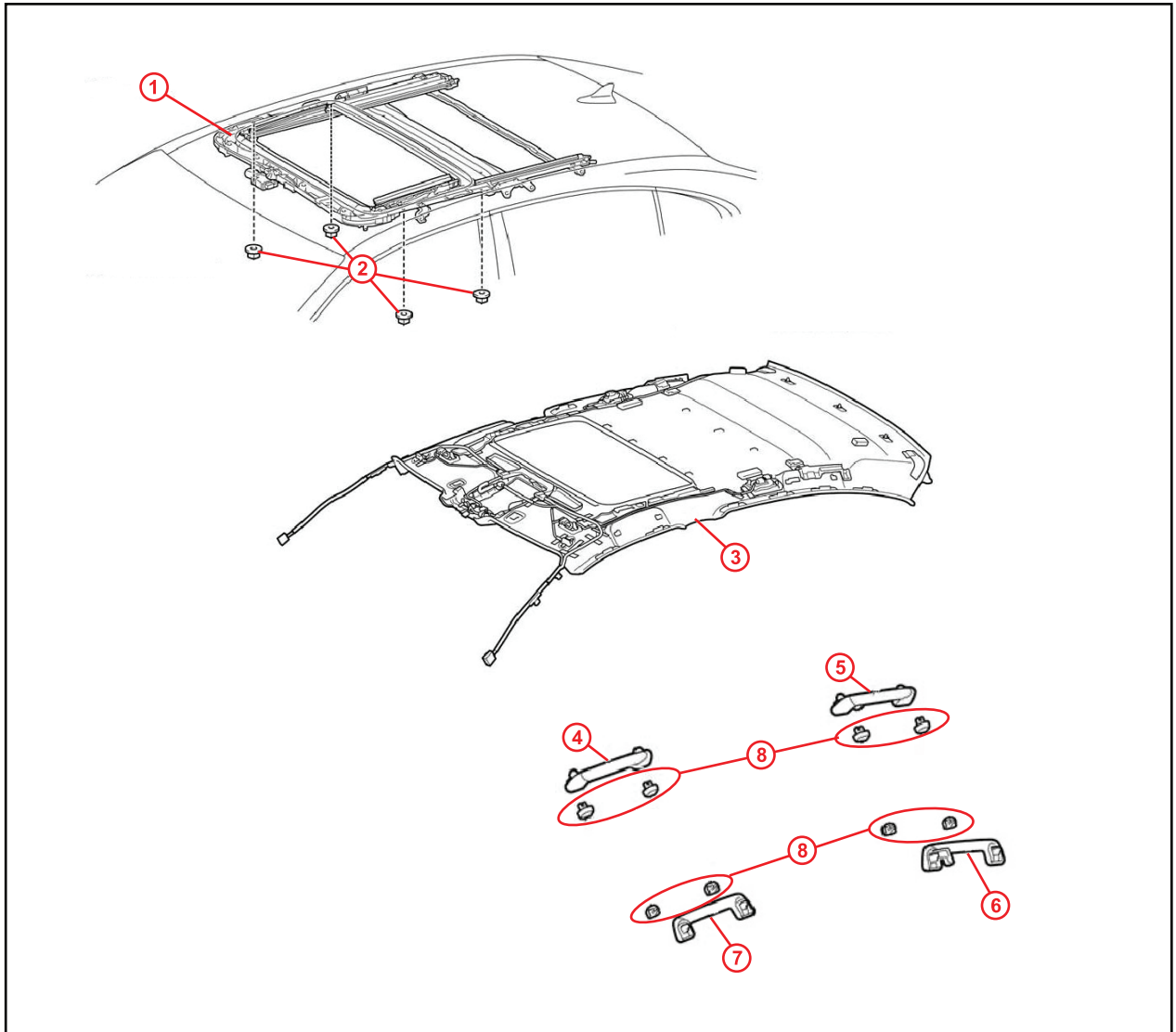

1	Sliding Roof
2	Mounting Nut
3	Roof Headlining Assembly
4	Front Assist Grip Assembly RH

5	Rear Assist Grip Assembly RH
6	Front Assist Grip Assembly LH
7	Rear Assist Grip Assembly LH
8	Assist Grip Cover*

* Replace assist grip covers with new ones.

Roof Panel Pop Noise

Repair Procedure (Continued)

NOTE

After turning the ignition switch OFF, waiting time may be required before disconnecting the cable from the battery terminal. Make sure to read the Notice for disconnecting the cable from the battery terminal before proceeding with work. Record customer's radio presets, and customized settings.

Refer to the Technical Information System (TIS), applicable model and model year Repair Manual:

- 2013 GS [350](#) / [450h](#):
Repair Instruction – Precaution – “Introduction: Repair Instruction: Precaution”

HINT

Use the same procedures described below for the RH side unless stated otherwise.

1. Slide the sliding roof to the full open position.

HINT

Since replacement of sliding roof mounting nuts requires plenty of workspace, the sliding roof needs to be opened in advance.

2. Move the front seats to the most forward position.

HINT

Since removal of the upper center pillar garnishes requires plenty of workspace, the seats need to be moved in advance.

3. Disconnect the cable from the negative (–) battery terminal.

CAUTION

Wait for at LEAST 90 seconds after disconnecting the cable to ensure the airbags are no longer operational.

Roof Panel Pop Noise

Repair Procedure (Continued)

4. Remove the front door scuff plate LH.
 - A. Put protective tape around the front door scuff plate LH.
 - B. Using a plastic pry tool, detach the 10 claws and 4 clips and remove the front door scuff plate LH.

Figure 4.

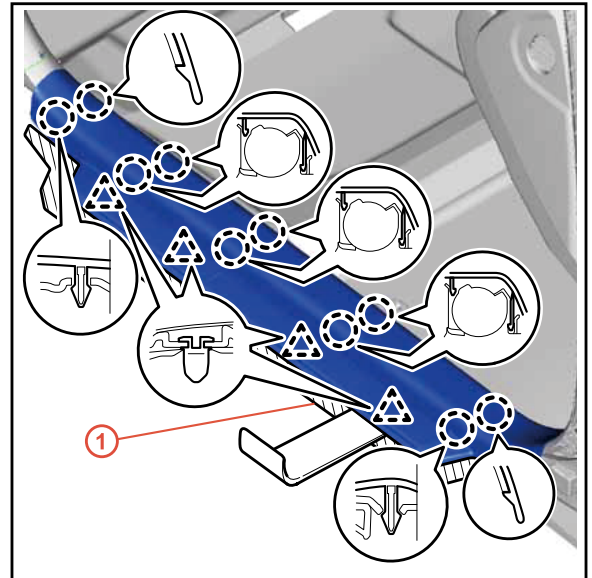

1 Protective Tape

5. Detach the 2 claws and partially detach the front door opening trim cover LH from the front pillar garnish.

NOTE
Do NOT remove the front door opening trim cover.

Figure 5.

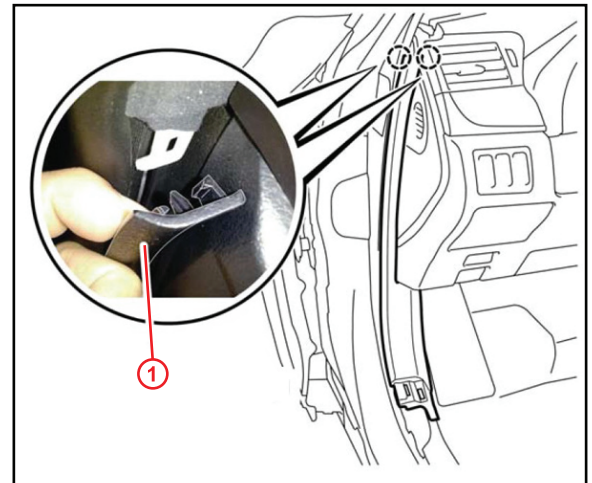

1 Front Door Opening Trim Cover

Roof Panel Pop Noise

Repair Procedure (Continued)

6. Remove the front pillar garnish LH.
 - A. Pull the upper part of the garnish toward the inside of the cabin and detach the 2 clips.

HINT

Make sure the front pillar garnish LH hangs down from the upper front pillar garnish clip.

Figure 6.

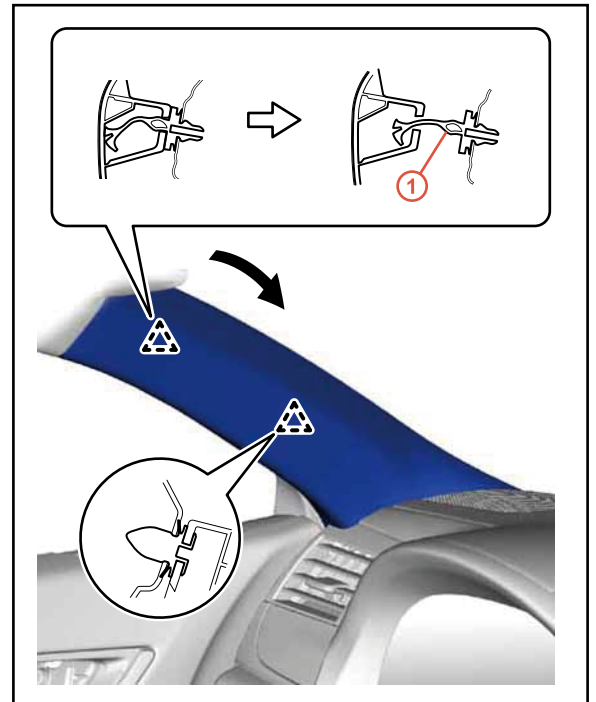

1	Front Pillar Garnish Clip
----------	----------------------------------

Roof Panel Pop Noise

Repair Procedure (Continued)

- B. Turn the end of the front pillar garnish clip 90° with needle-nose pliers in order to remove the garnish from the A pillar.

NOTE

Replace the upper front pillar garnish clips with new ones.

HINT

Tape the tips of the needle-nose pliers before use.

Figure 7.

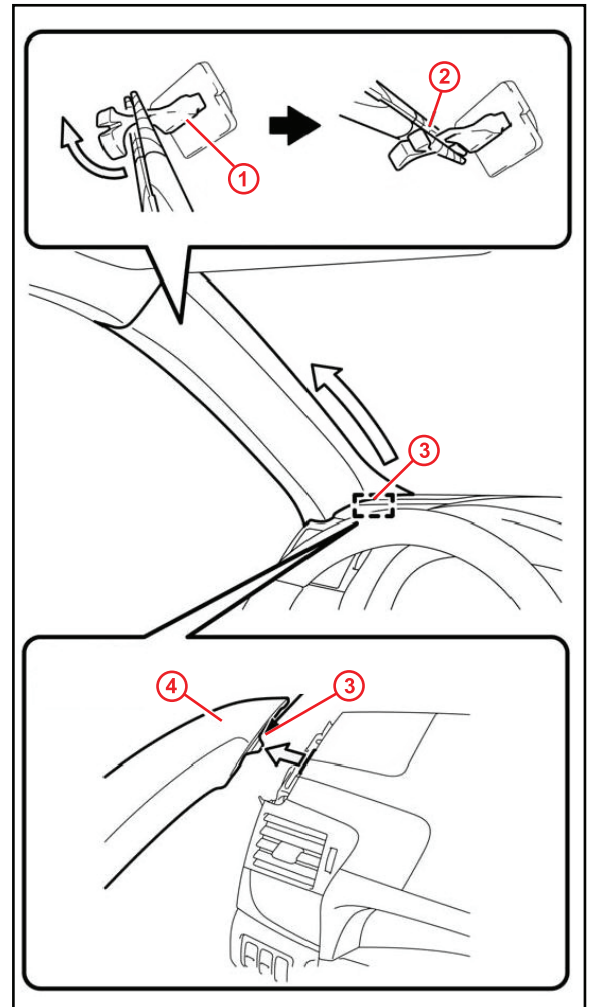

1	Front Pillar Garnish Clip
2	Protective Tape
3	Guide
4	Front Pillar Garnish

- C. Detach the bottom guide and remove the front pillar garnish LH.
 D. Remove the upper front pillar garnish clip from the A pillar and discard the garnish clip.

Roof Panel Pop Noise

Repair Procedure (Continued)

- E. Protect the curtain shield airbag assembly by completely covering the airbag with a cloth or nylon sheet and secure the ends of the cover with adhesive tape as shown in the illustration.

NOTICE

Cover the curtain shield airbag with a protective cover as soon as the front pillar garnish is removed.

Figure 8.

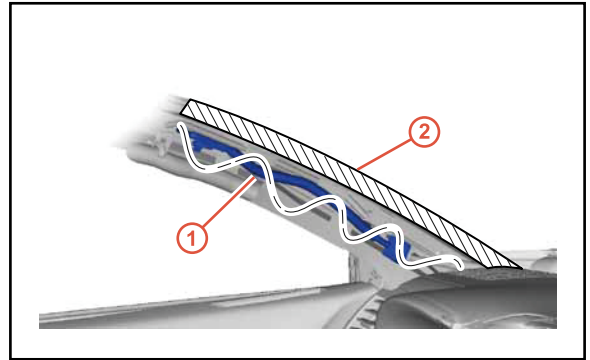

1	Protective Cover
2	Adhesive Tape

- 7. Remove the rear door scuff plate LH.
 - A. Put protective tape around the rear door scuff plate LH.
 - B. Using a plastic pry tool, detach the 10 claws and 3 clips and remove the rear door scuff plate LH.

Figure 9.

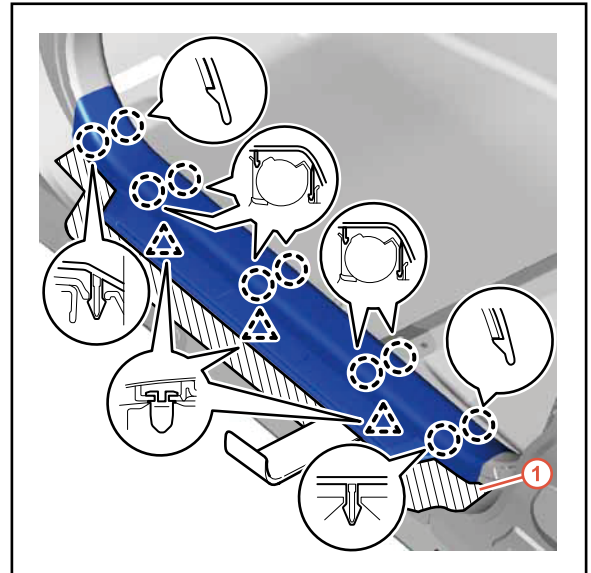

1	Protective Tape
---	-----------------

Roof Panel Pop Noise

Repair Procedure (Continued)

8. Remove the lower center pillar garnish LH.
 - A. Pull both sides of the lower center pillar garnish LH outward to detach the 2 claws.
 - B. Detach the 5 clips and 2 guides and remove the lower center pillar garnish LH.

Figure 10.

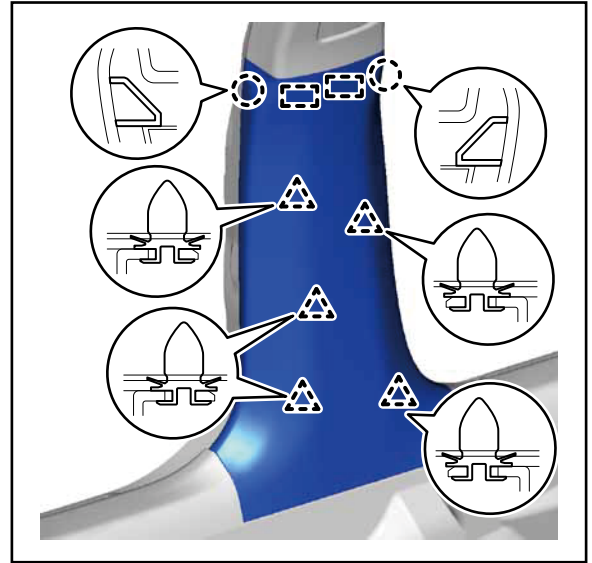

9. Remove the upper center pillar garnish LH.
 - A. Remove the 2 screws.
 - B. Initially, pull both sides of the upper center pillar garnish LH outward to remove the center pillar garnish LH.
 - C. Detach the clip.
 - D. Remove the clip from the upper center pillar garnish.

Figure 11.

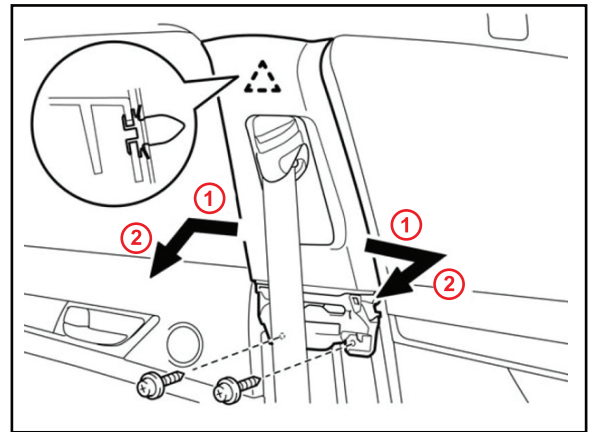

NOTE
Replace the clip with a new one.

1	Pull Outward
2	Pull Away

Roof Panel Pop Noise

Repair Procedure (Continued)

- While being careful NOT to apply force to the camera, detach the 6 claws, guide, and fastener and remove the front roof top garnish (w/ Night View system).

NOTICE

w/ Lane Keep Assist (LKA) system: When removing and installing the front roof top garnish, do NOT apply force to the camera sensor located at (x) in the diagrams.

Figure 12.

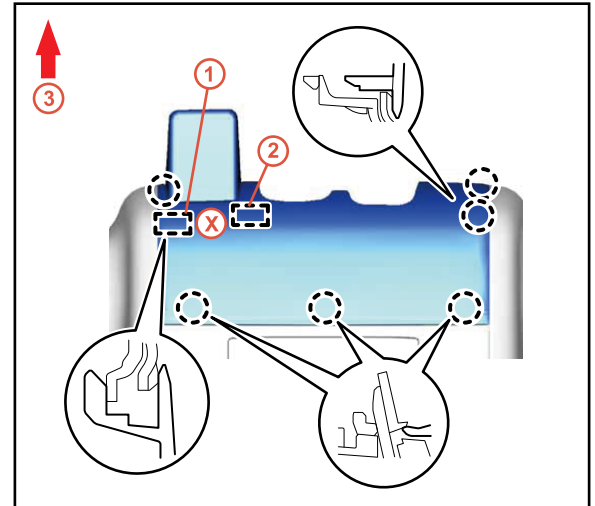

1	Guide
2	Fastener
3	Front

Roof Panel Pop Noise

Repair Procedure (Continued)

Figure 13.

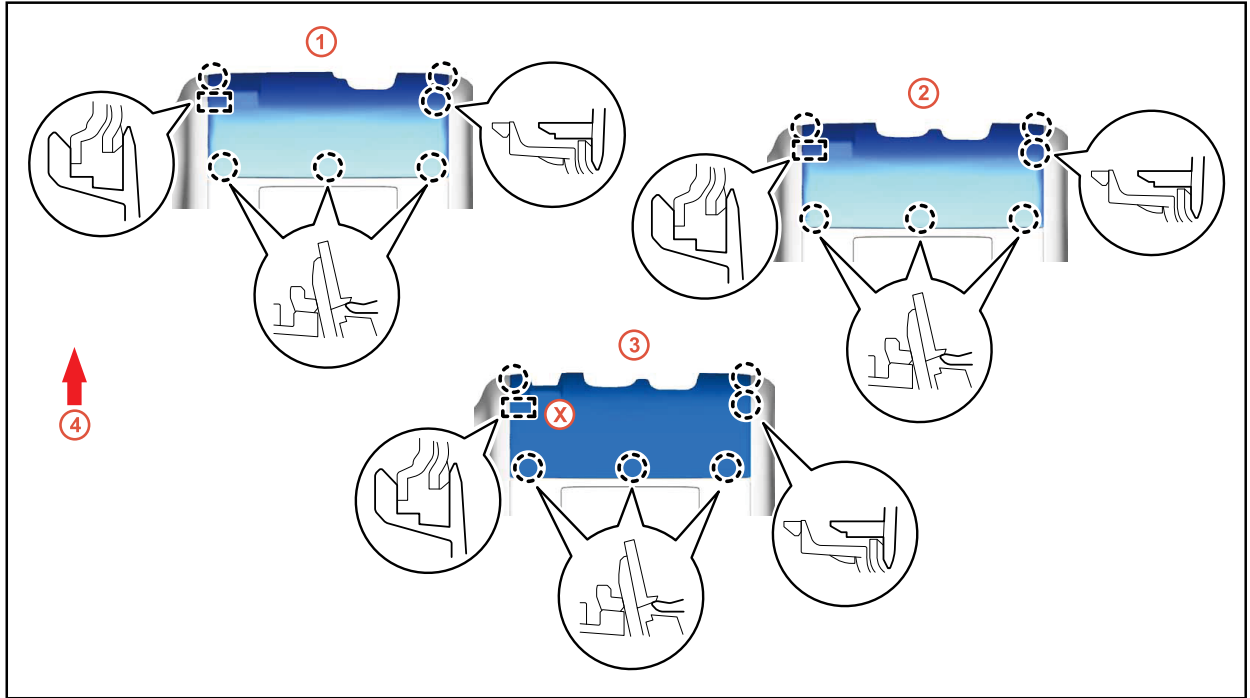

1	Standard
2	Rain Sensor

3	Lane Keep Assist System
4	Front

Roof Panel Pop Noise

Repair Procedure (Continued)

11. While being careful NOT to apply force to the camera (for vehicles with the Lane Keep Assist system), detach the 6 claws and guide and remove the front roof top garnish (w/o Night View system).

NOTICE

When removing and installing the front roof top garnish, do NOT apply force to the camera sensor located at (x) in Figures 12 & 13.

12. Remove the map light assembly.
 - A. Using a plastic pry tool, detach the 4 clips and 2 guides.
 - B. Disconnect the 2 connectors and remove the map light assembly.

Figure 14.

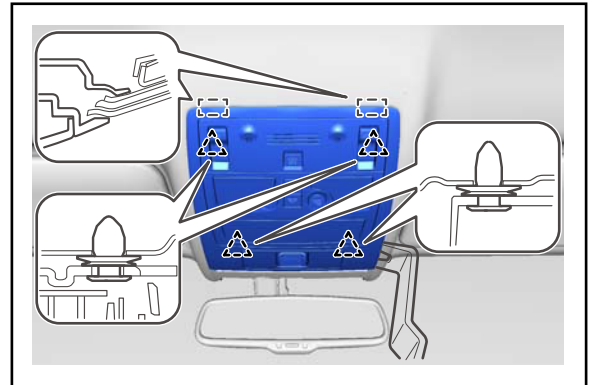

13. Using a plastic pry tool, detach the 4 claws and remove the visor bracket cover.

HINT

Use the same procedure for both visor bracket covers.

Figure 15.

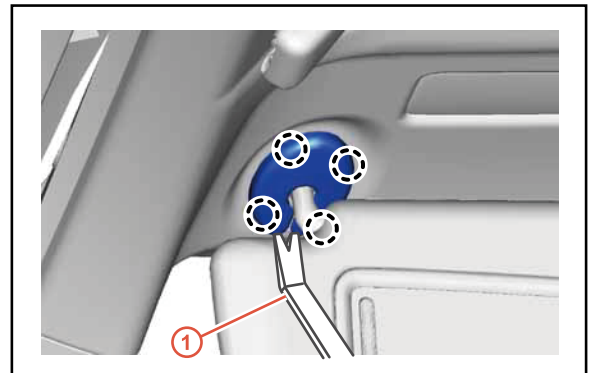

1 Plastic Pry Tool

Roof Panel Pop Noise

Repair Procedure (Continued)

14. Remove the visor assembly LH.
 - A. Detach the guide from the visor holder.
 - B. Remove the 2 screws and visor assembly LH.

Figure 16.

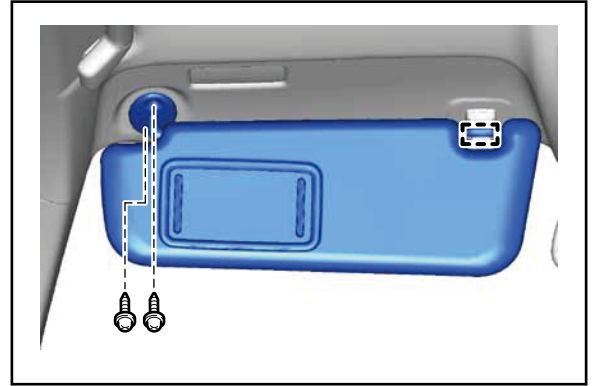

15. Remove the visor holder.
 - A. Turn the visor holder clockwise approximately 45° and pull it out as shown in the illustration.
 - B. Detach the 2 claws and remove the visor holder.

Figure 17.

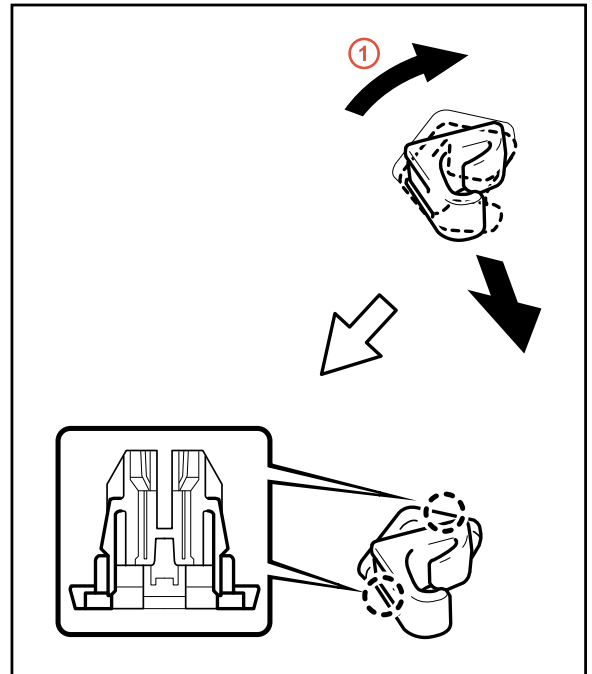

1	Turn 45°
----------	----------

Roof Panel Pop Noise

Repair Procedure (Continued)

16. Remove the front assist grip sub-assembly LH.

- A. Put protective tape around the assist grip covers.
- B. Using a plastic pry tool, detach the 4 claws and remove the 2 assist grip covers.

NOTE

Replace assist grip covers with new ones.

- C. Detach the 2 clips and remove the front assist grip sub-assembly.
- D. Remove the 2 clips from the vehicle body.

Figure 18.

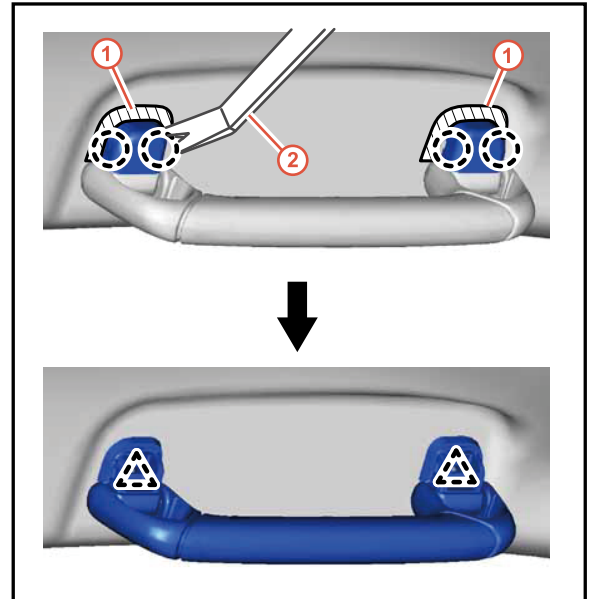

1	Protective Tape
2	Plastic Pry Tool

17. Remove the rear assist grip assembly LH.

- A. Put protective tape around the assist grip covers.
- B. Using a plastic pry tool, detach the 4 claws and remove the 2 assist grip covers.

NOTE

Replace assist grip covers with new ones.

- C. Detach the 2 clips and remove the rear assist grip assembly LH.
- D. Remove the 2 clips from the vehicle body.

Figure 19.

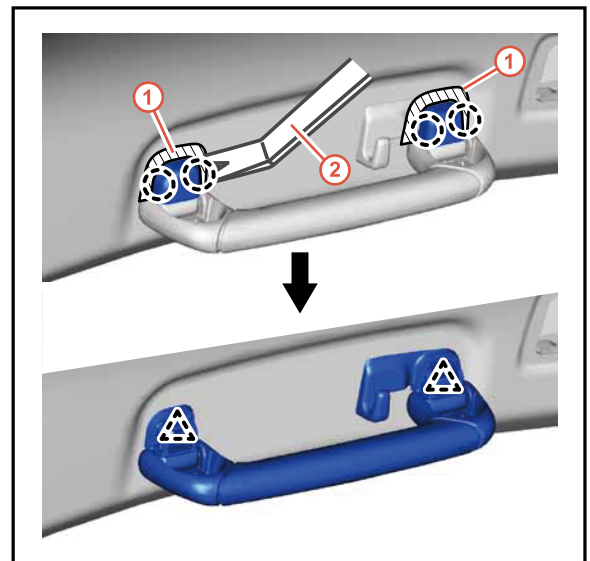

1	Protective Tape
2	Plastic Pry Tool

Roof Panel Pop Noise

Repair Procedure (Continued)

18. Detach the 12 claws, guide, and 8 fasteners and partially detach the roof headlining assembly.

NOTICE

- This is a **FRAGILE PART!** Take extra care not to bend the roof headliner, as this can easily damage the part.
- Perform nut replacement with an assistant in order to prevent damage to the headliner.
- If the back of a fastener has become detached from the headliner assembly or the sunroof frame assembly, repair it with the specified adhesive (or equivalent).
- It is **NOT** necessary to completely remove the headliner to gain access to the sliding roof mounting bolts.

Figure 20.

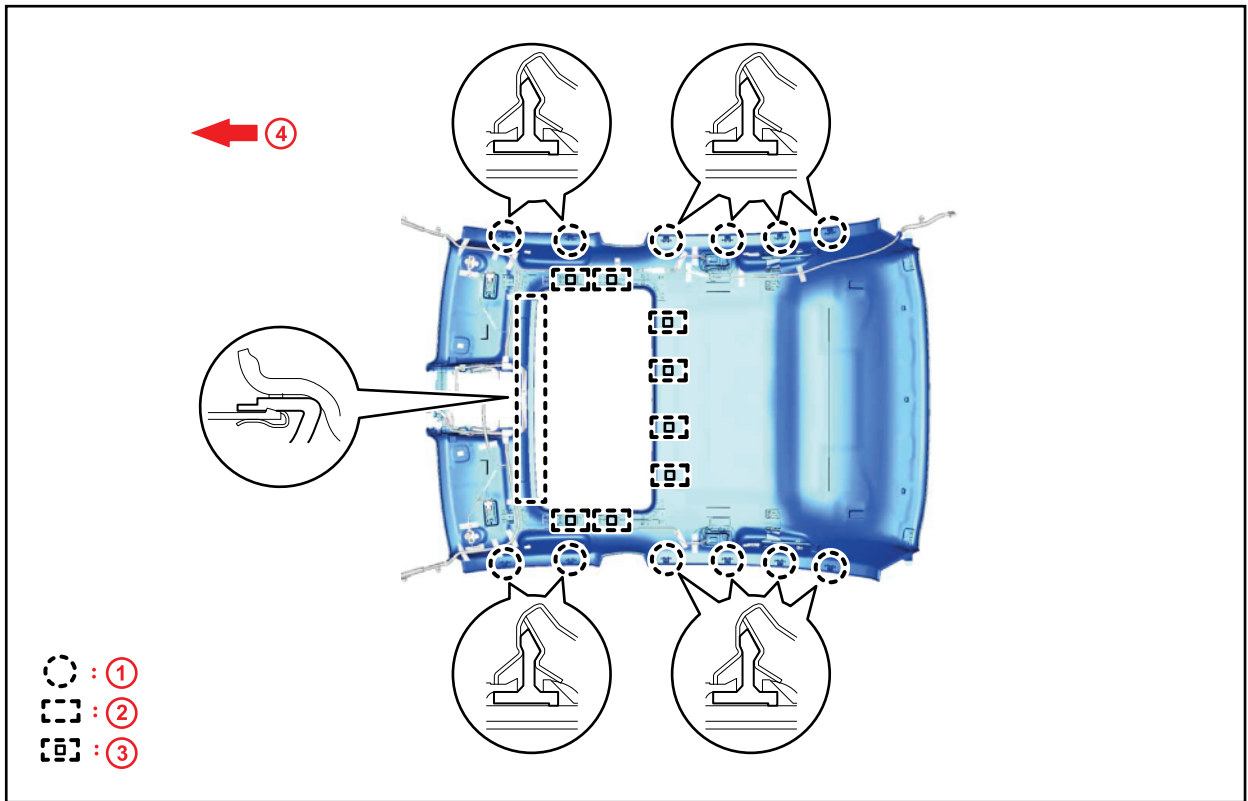

1	Fastener
2	Guide

3	Claw
4	Front

Roof Panel Pop Noise

Repair Procedure (Continued)

19. Remove the 4 nuts from the sliding roof from the locations shown.

Figure 21.

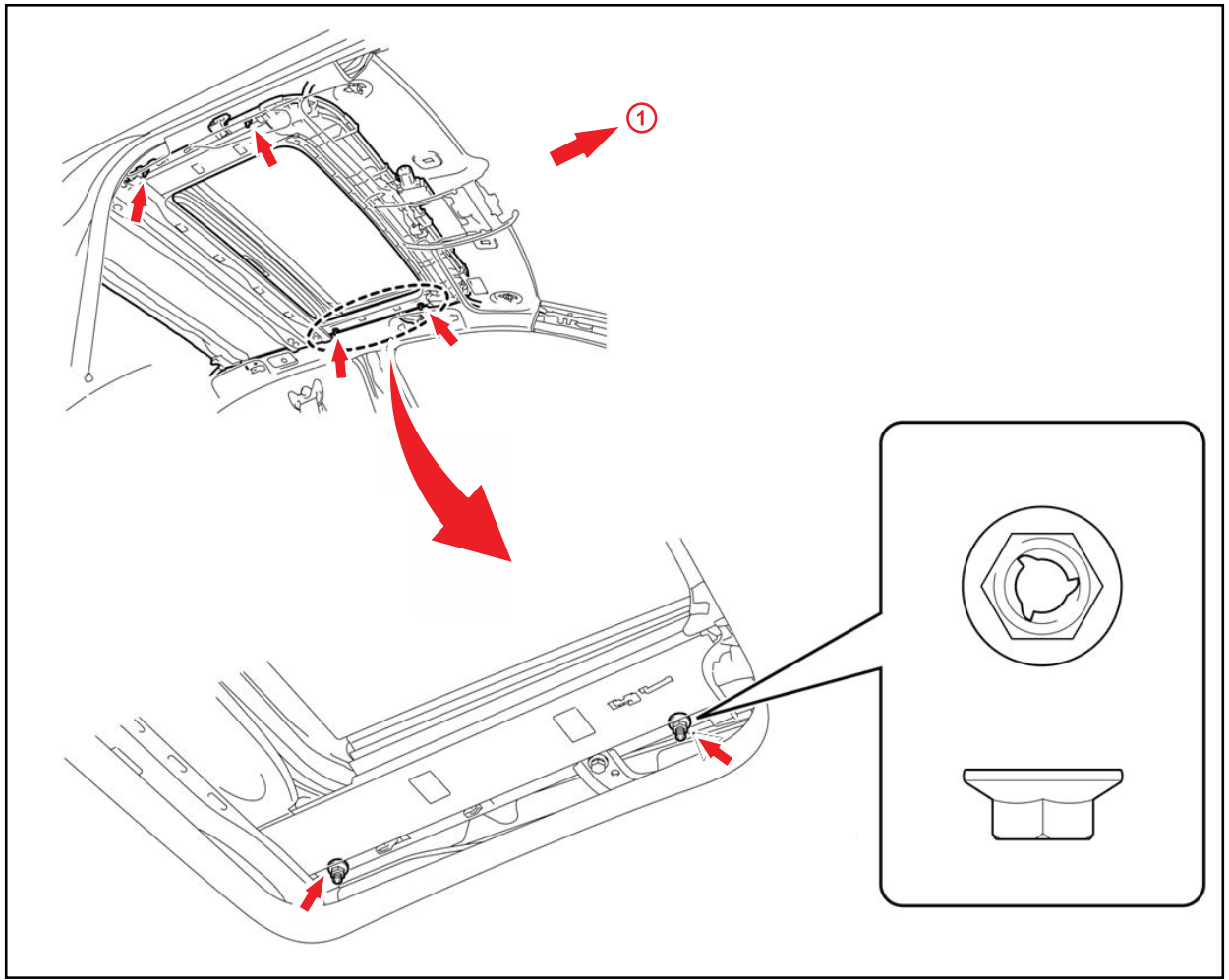

1	Front
---	-------

Roof Panel Pop Noise

Repair Procedure (Continued)

NOTICE
 Perform nut replacement with an assistant in order to prevent damage to the headliner.

Figure 22.

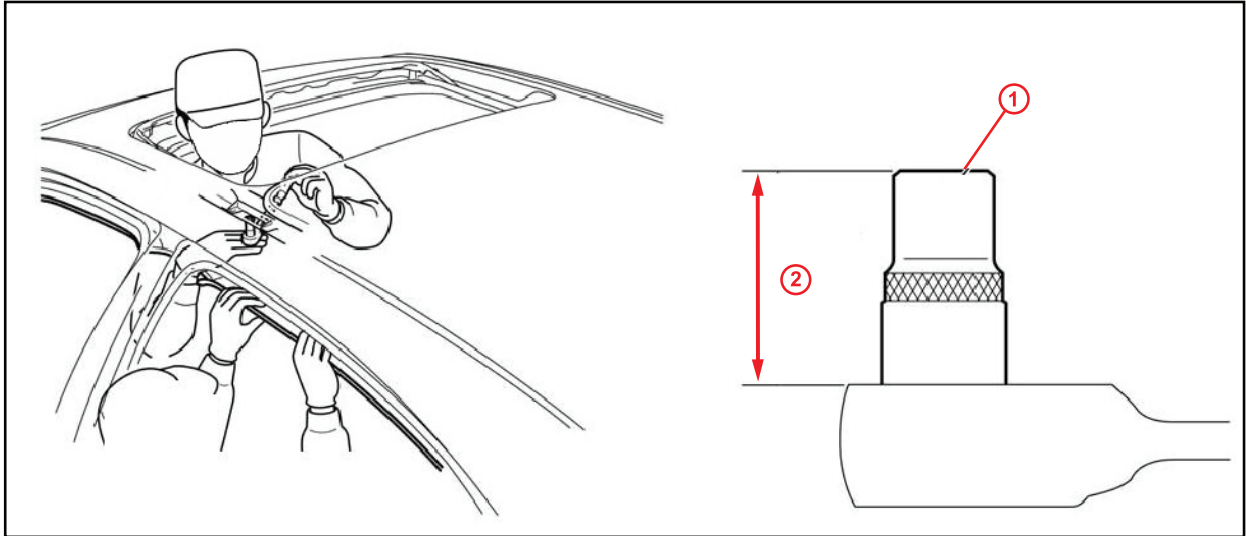

1 | Socket Wrench

2 | Approximately 30 mm (1.18 in.)

20. Install the sliding roof mounting nuts.

NOTICE

- Use the specified torque to tighten the nuts. If excessive torque is applied, the studs may break.
- Perform nut replacement with an assistant in order to prevent damage to the headliner.

Roof Panel Pop Noise

Repair Procedure (Continued)

Figure 23.

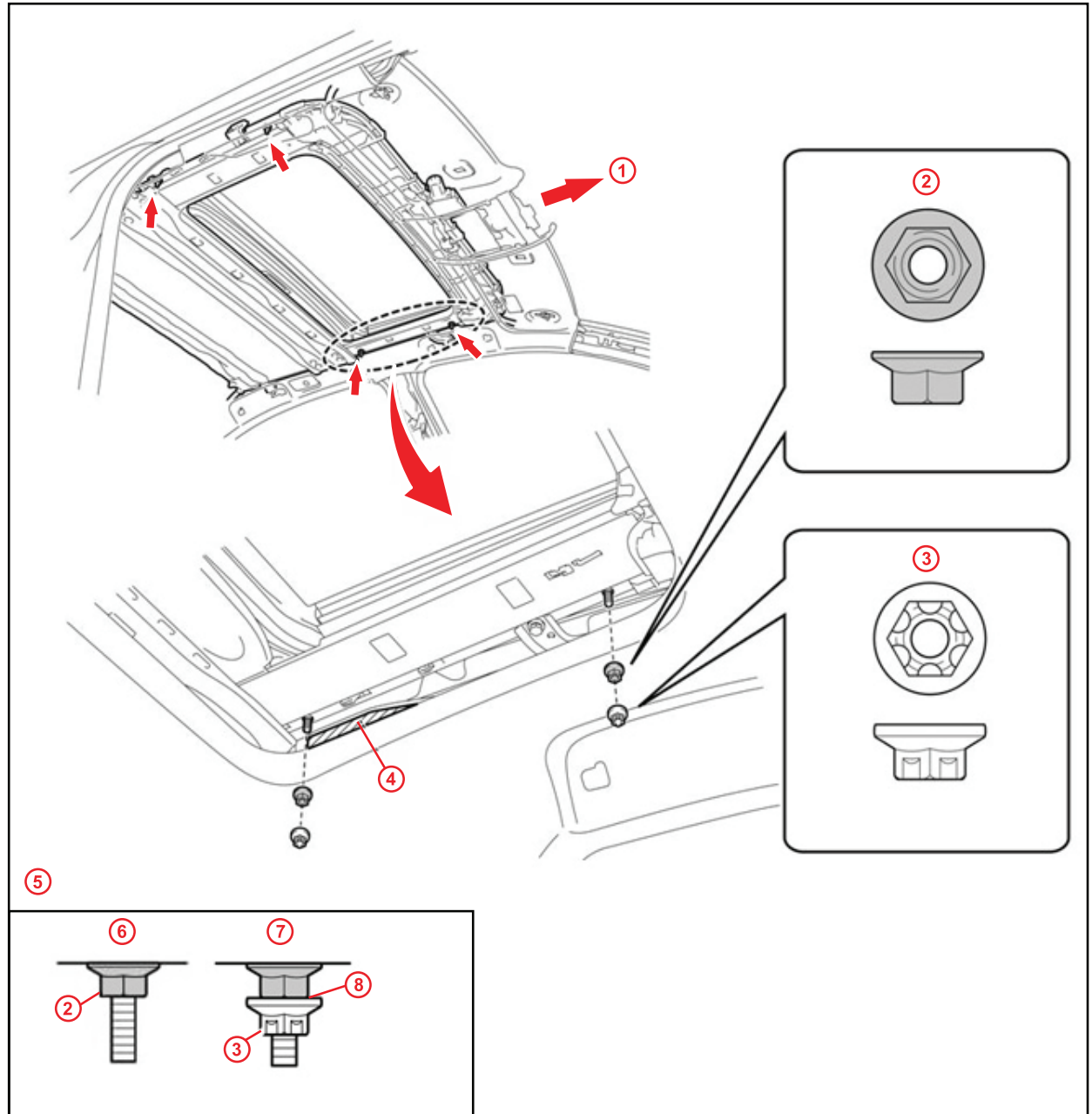

1	Front
2	Black (P/N 90179-06274)
3	Silver (P/N 90177-06002)
4	Curtain Shield Airbag

5	Installation
6	Step 1
7	Step 2
8	Ensure that Both Nut Surfaces Are Evenly and Firmly in Contact With Each Other

Roof Panel Pop Noise

Repair Procedure (Continued)

- A. Tighten the 4 new nuts (black).
Torque: 7 N*m (71 kgf*cm, 62 in*lbf)
- B. Tighten the 4 new lock nuts (silver).
Torque: 7 N*m (71 kgf*cm, 62 in*lbf)

NOTICE

Pay attention NOT to get the curtain shield airbag caught when the nuts are tightened.

- 21. Attach the 12 claws, guide, and 8 fasteners to install the roof headlining.

HINT

If the back of a fastener becomes detached from the headliner assembly or the sunroof frame assembly, repair it with the specified adhesive (or equivalent).

Figure 24.

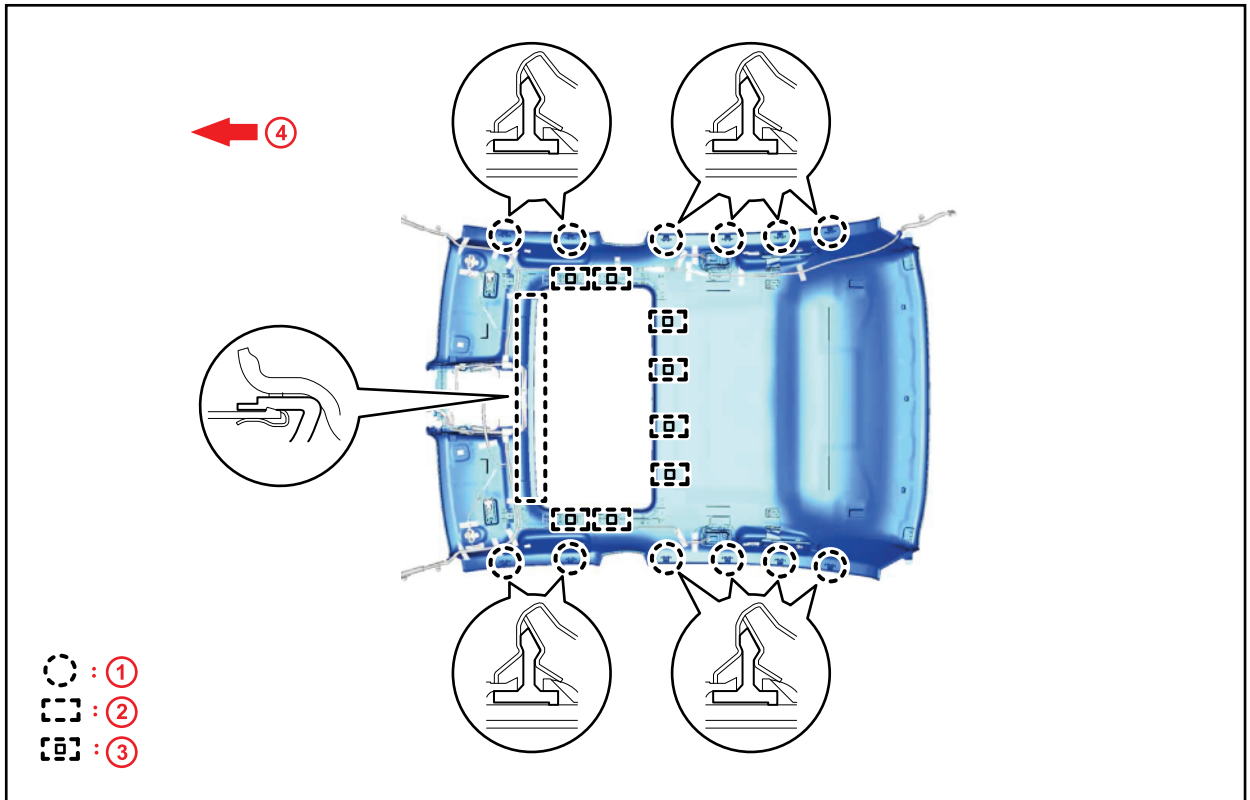

1	Fastener
2	Guide

3	Claw
4	Front

Roof Panel Pop Noise

Repair Procedure (Continued)

22. Install the front assist grip sub-assembly LH.
 - A. Attach the clips to the assist grip as shown in the illustration.
 - B. Attach the assembly into the vehicle.
 - C. Attach the 2 new assist grip covers in place and ensure grip assembly is secure.

NOTE
Use new assist grip covers.

Figure 25.

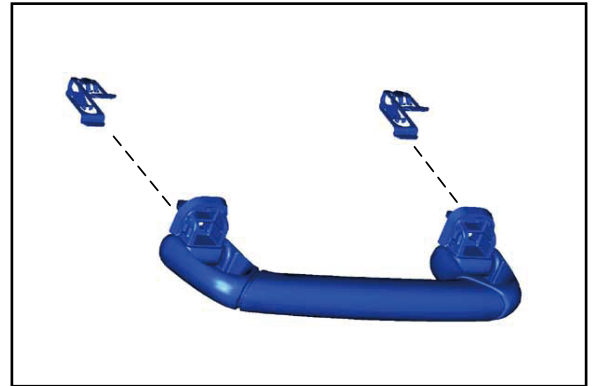

23. Install the rear assist grip assembly LH.
 - A. Attach the clips to the rear assist grip as shown in the illustration.
 - B. Attach the assembly into the vehicle.
 - C. Attach the 2 new assist grip covers in place and ensure grip assembly is secure.

NOTE
Use NEW assist grip covers.

Figure 26.

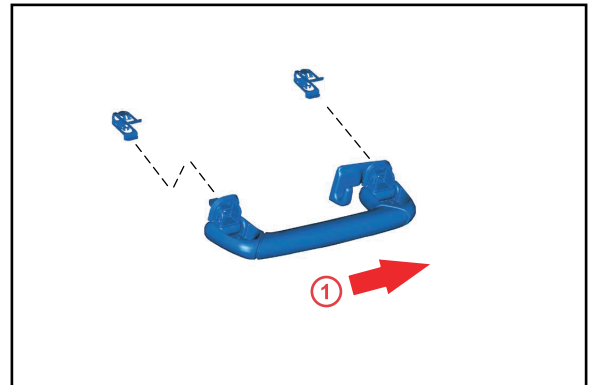

1	Front
----------	-------

24. Install the visor holder.
 - A. Attach the 2 claws.
 - B. Push in the visor holder to install it.
25. Install the visor assembly LH.
 - A. Install the visor assembly LH with the 2 screws.
 - B. Attach the guide to visor holder.
26. Attach the 4 claws to install the visor bracket cover.

Roof Panel Pop Noise

Repair Procedure (Continued)

27. Install the map light assembly.
 - A. Connect the 2 connectors.
 - B. Attach the 4 clips and 2 guides to install the map light assembly.
28. While being careful NOT to apply force to the camera, attach the 6 claws, guide, and fastener to install the front roof top garnish (w/ Night View system).

NOTICE

When installing the front roof top garnish, do not apply force to the camera sensor located at the (x) shown in Figures 12 & 13.

29. While being careful not to apply force to the camera (for vehicles with the Lane Keep Assist system), attach the 6 claws and guide to install the front roof top garnish .

NOTICE

With Lane Keep Assist system: When removing and installing the front roof top garnish, do not apply force to the camera sensor location.

30. Install the upper center pillar garnish LH.
 - A. Install the new clip onto the upper center pillar garnish (P/N 90467-10167).
 - B. Attach the clip to install the upper center pillar garnish LH.
 - C. Install the 2 lower mounting screws.

NOTICE

After installing the upper center pillar garnish LH, make sure that the lip of the front door opening trim weatherstrip LH and rear door opening trim weatherstrip LH is NOT pinched.

31. Install the lower center pillar garnish LH.
 - A. Attach the 5 clips and 2 guides.
 - B. While pulling both sides of the lower center garnish outward by hand, set the garnish in place, and then attach the 2 claws to install the lower center pillar garnish LH.

NOTICE

After installing the lower center pillar garnish LH, make sure that the lip of the front door opening trim weatherstrip LH and rear door opening trim weatherstrip LH is NOT pinched.

32. Attach the 10 claws and 3 clips to install the rear door scuff plate LH.

Roof Panel Pop Noise

Repair Procedure (Continued)

33. Install front pillar garnish LH.

- A. Install the U-shaped end of the new upper front pillar garnish clip on the garnish and rotate the clip 90° inside of the garnish.

Figure 27.

NOTE

Use the new front pillar garnish clip.

HINT

Tape the tips of the needle-nose pliers before use.



- B. Attach the lower guide into place.

- C. Insert both clips into the A pillar.

Figure 28.

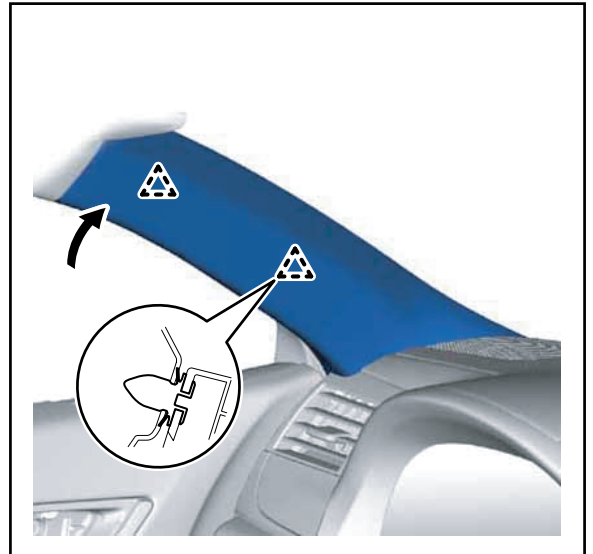

NOTICE

After installing the front pillar garnish LH, make sure that the lip of the front door opening trim weatherstrip LH is NOT pinched.

Roof Panel Pop Noise

Repair Procedure (Continued)

- D. Attach the 2 claws to install the front door opening trim cover LH.

Figure 29.

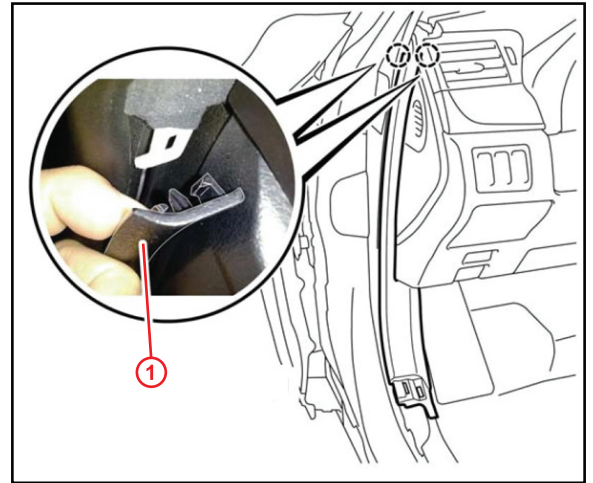

1 Front Door Opening Trim Cover

34. Attach the 10 claws and 4 clips to install the front door scuff plate LH.
35. Connect the cable to the negative (–) battery terminal.

NOTE

When disconnecting the cable, some systems need to be initialized after the cable is reconnected.

36. Initialize all affected systems.

Refer to:

- [L-PDSB-0206](#): Lexus 2013 GS350 PDS Manual
- [L-PDSB-0210](#): Lexus 2013 GS450h PDS Manual

37. Confirm successful repair.